

STUDER

A80 R

SERVICEANLEITUNG
SERVICE INSTRUCTIONS



EINLEITUNG

Das vorliegende Buch ist eine Neubearbeitung der Bedienungs- und Serviceanleitung für das professionelle Magnetongerät A80 R.

Es entstand aus dem deutsch-englischen Buch von 1975 und der französischen Bearbeitung von 1976.

Inzwischen erfolgte Änderungen oder Neuerungen wurden berücksichtigt.

Der Schemateil (Section 6–9) enthält die Schemata sämtlicher A80 R Ausführungen. Section 9 beinhaltet speziell die Schemata der älteren A80 R Magnetongeräte.

INTRODUCTION

This book is a revised edition of the operating and service instructions for the professional tape recorder A80 R.

It grew out of the German-English manual issued 1975 and the French editing issued 1976.

Modifications and innovations have been considered.

The schematic part (section 6...9) includes the schematics of all A80 R versions. Section 9 especially contains the earlier schematics of the A80 R tape recorder.

Prepared and edited by
STUDER REVOX
TECHNICAL DOCUMENTATION
Althardstrasse 146
CH - 8105 Regensdorf - Zürich

Copyright by Willi Studer
Printed in Switzerland
Order No. 23.272.480

We reserve the right to make alterations.

SECTION 1: ALLGEMEINES

STUDER A80 R, Ausführungen, technische Daten, Abmessungen

SECTION 2: INBETRIEBNAHME/BEDIENUNG

Inbetriebnahme, Anschlüsse, Zubehör, Pegel, Bedienung, Fernsteuerung

SECTION 3: AUSBAU DER BAUGRUPPEN

Allgemeines, Ausbau der Baugruppen, Abkürzungen, Signale, Funktionsbeschreibungen Laufwerk, Steuerlogik

SECTION 4: LAUFWERKEINSTELLUNGEN

Mechanische Einstellungen, elektrische Einstellungen, Prüfen, Gruppenübersicht, STUDER WIRING LIST

SECTION 5: VERSTÄRKER-EINSTELLUNGEN

Allgemeines, Anschlüsse, Wiedergabe- und Aufnahmeeinstellungen

SECTION 6: SCHEMATA (ALLGEMEIN)

SECTION 7: SCHEMATA (LAUFWERK)

SECTION 8: SCHEMATA (AUDIO)

SECTION 9: SCHEMATA (ÄLTERE AUSFÜHRUNGEN)

SECTION 10: ERSATZTEILE

SECTION 1: GENERAL

A80 R 3

STUDER A80 R, versions, technical data, dimensions

SECTION 2: PUTTING INTO OPERATION/OPERATING

Putting into operation, connections, accessories, level, operating, remote control

SECTION 3: REMOVAL OF ASSEMBLIES

General, removal of assemblies, abbreviations, signals, functional description of tape drive, control logic

SECTION 4: TAPE TRANSPORT CALIBRATION

Mechanical settings, electrical adjustments, checks, summary of equipment modules, STUDER WIRING LIST

SECTION 5: AMPLIFIER ADJUSTMENTS

General, connections, playback- and record adjustments

SECTION 6: SCHEMATICS (GENERAL)

SECTION 7: SCHEMATICS (TAPE TRANSPORT)

SECTION 8: SCHEMATICS (AUDIO)

SECTION 9: SCHEMATICS (EARLIER VERSIONS)

SECTION 10: PARTS LIST

INHALTSVERZEICHNIS

TABLE OF CONTENTS

SECTION 1 ALLGEMEINES

GENERAL

1.1	STUDER A80 R professionelles Magnetongerät	STUDER A80 R professional tape recorder	1/1
1.1.1	Ausführungen der A80 R Magnetongeräte in Konsole	Console version of the A80 R tape recorder	1/1
1.1.2	Ausführungen mit Kontrolleinheit (VU-Panel)	VU-meter panel versions of the A80 R tape recorder	1/1
1.2	Technische Daten	Technical data	1/2
1.3	Abmessungen	Dimensions	1/5

SECTION 2 INBETRIEBNAHME / BEDIENUNG

PUTTING INTO OPERATION / OPERATING INSTRUCTIONS

2.1	Inbetriebnahme des Gerätes	Putting into operation	2/1
2.1.1	Kontrollen vor Inbetriebnahme	Checks prior initial operation	2/1
2.1.2	Erdung	Grounding	2/2
2.1.3	Funktionsprüfung	Function test	2/2
2.1.4	Adapter für 1/4" Geräte	Adaptors for 1/4" tape units	2/2
2.1.5	NF-Anschlüsse	AF connections	2/3
2.1.6	Pegel	Level	2/3
2.2	Bedienung	Operation	2/3
2.2.1	Drucktasten	Push buttons	2/3
2.2.2	Bandzähler	Tape counter	2/4
2.2.3	Elektronischer Bandzähler	Electronic tape counter	2/4
2.2.4	Taste EDIT (6)	EDIT key (6)	2/4
2.2.5	Reglerknopf EDIT (für variables Umspulen)	EDIT control (for variable winding)	2/4
2.2.6	Schnell-Start	Quickstart	2/5
2.3	Fernsteuerung Laufwerk	Remote control for tape deck	2/5
2.3.1	Anschluss "Capstan speed control"	Connector "capstan speed control"	2/7
2.4	Papierkorbbetrieb	Waste-paper basket mode	2/8

SECTION 3 AUSBAU DER BAUGRUPPEN

REMOVAL OF ASSEMBLIES

3.1	Allgemeines	General	3/1
3.1.1	Abdeckbleche des Laufwerkes abnehmen	Removal of cover plates from tape drive unit	3/1
3.1.2	Tonmotor ausbauen	Removal of capstan motor	3/1
3.1.3	Wickelmotoren mit Bremsaggregat ausbauen	Removal of spooling motor with brake unit	3/2
3.1.4	Kopfträger ausbauen	Removal of head block assembly	3/2
3.1.5	Andruckaggregat ausbauen	Removal of pinch roller assembly	3/2
3.1.6	Federdämpfungselemente ausbauen	Removal of spring and damping unit	3/2
3.1.7	Bauzugwaagen ausbauen	Removal of tape tension sensor	3/2
3.1.8	Linke Bandumlenkrolle ausbauen	Dismantling of left hand guide roller	3/3
3.1.9	Rechte Bandumlenkrolle (Bandbewegungssensor) ausbauen	Dismantling of right hand guide roller (tape motion sensor)	3/3
3.1.10	Drucktastenaggregat und Zähler ausbauen	Dismantling of push button unit and counter	3/3
3.1.11	Netz- und Geschwindigkeitsschalter ausbauen	Dismantling of AC power switch and speed selector	3/3
3.1.12	EDIT-Regler (für variables Umspulen) ausbauen	Dismantling of EDIT control assembly (variable wind)	3/3
3.1.13	Netzeinheit ausbauen	Dismantling of power supply	3/4
3.2	Allgemeine Abkürzungen	Explanation of abbreviations	3/4
3.2.1	Signalabkürzungen	Signal abbreviations	3/4
3.2.2	Signalnamen	Signal labels	3/4
3.2.3	Referenzbezeichnungen	Reference labels	3/5
3.2.4	Transistoranschlüsse	Transistor connections	3/5
3.2.5	Drahtfarben	Wiring colors	3/5
3.2.6	Micro-Switches-Anschlüsse	Microswitch connections	3/6

3.3	Funktionsbeschreibung der Laufwerksteuerung	Functional description of tape drive control	3/6
3.3.1	Anordnung der Steuerelektronik	Layout of electronic controls	3/6
3.3.2	Drucktasten	Control switches	3/7
3.3.3	Reglerstart	Fader start	3/7
3.3.4	Verriegelung	Interlocks	3/7
3.3.5	EDIT-Taste	EDIT key	3/7
3.3.6	Zwischenhören	Cueing	3/8
3.3.7	Automatischer EDIT-Betrieb	Automatic EDIT operations	3/8
3.4	Steuerlogik	Control logic	3/8
3.4.1	Eingangsabschwächer ATTENUATOR AND PREAMP	ATTENUATOR AND PREAMP	3/8
3.4.2	IC-MEMORY AND COUNTER	IC-MEMORY AND COUNTER	3/10
3.4.3	IC-DECODER AND DRIVERS	IC-DECODER AND DRIVERS	3/12
3.4.4	Wickelmotorsteuerung SPOOLING MOTOR CONTROL	SPOOLING MOTOR CONTROL	3/13
3.4.5	Wickelmotor-Schützen CONTACTORS	Spooling motor CONTACTORS	3/14

SECTION 4 LAUFWERKEINSTELLUNGEN		TAPE TRANSPORT CALIBRATION	
4.1	Mechanische Laufwerkeinstellungen	Mechanical tape transport settings	4/1
4.1.1	Mechanische Bremsen	Mechanical brakes	4/1
4.1.2	Andruck-Aggregat	Pinch-roller assembly	4/2
4.1.3	Bandzugwaage	Tape tension sensor	4/5
4.2	Elektrische Einstellungen	Electrical setting	4/7
4.2.1	Stabilisator (voltage regulator)	Voltage regulator	4/7
4.2.2	Einstellen mit Bandzugmessgerät	Adjusting with tentelometer	4/9
4.2.3	Bandzug Wiedergabe	Tape tension for playback	4/9
4.2.4	Bandzugbegrenzung schnelles Umspulen	Tape tension limitation during fast wind	4/10
4.2.5	Bandzugbegrenzung EDIT (CUTAUT)	Peak tape tension limitation EDIT (CUTAUT)	4/11
4.2.6	Bremsregelung	Brake adjustments	4/12
4.2.7	Tonmotorregelung, Abgleich	Capstan motor servo balancing	4/13
4.2.8	Tonmotorregelung, Abgleich 1.080.376	Capstan motor servo balancing, circuit 1.080.376	4/14
4.3	Prüfen der Laufwerklogik	Checking of tape transport logic	4/15
4.3.1	Logische Ausgangs-Signale	Logical output signals	4/15
4.3.2	Logical Output Signals Nr. 1	Logical output-signals No. 1	4/16
4.3.3	Logical Output Signals Nr. 2	Logical output signals No. 2	4/16
4.3.4	Logical Output Signals Nr. 3	Logical output signals No. 3	4/16
4.3.5	Logical Output Signals Nr. 4	Logical output signals No. 4	4/17
4.4	ZERO LOCATOR 1.080.395	ZERO LOCATOR 1.080.395	4/22
4.4.1	Signalverarbeitung	Signal processing	4/22
4.4.2	Signallegende	Key to signals	4/23
4.5	Gruppenübersicht	Summary of equipment modules	4/25
4.6	Verdrahtungslisten	Wiring list	4/28
4.6.1	Gruppen	Component groups	4/28
4.6.2	Elemente, Punkte	Elements, points	4/28
4.6.3	Drahtbeschriftungen	Wire identification	4/28
4.7	Location pin list	Location pin list	4/29
4.8	Signal wire list	Signal wire list	4/30
4.9	Verdrahtungs-Typen (Anschluss-Typen)	Wiring methods (connection types)	4/31
4.9.1	STUDER WIRING LIST	STUDER WIRING LIST	4/32

SECTION 5 VERSTÄRKER-EINSTELLUNGEN		AMPLIFIER ADJUSTMENTS	
5.1	Allgemeines	General	5/1
5.1.1	Erläuterungen	Definitions	5/1
5.1.2	Bezeichnungen und Anschlüsse	Descriptions and connections	5/3
5.1.3	Messgeräte und Einstellwerkzeug	Measuring instruments and adjustment tools	5/6

5.2	Einstellen der +12V/-12V Speisungen der Verstärker	Adjustment of +12V/-12V amplifier supply voltage	5/6
5.3	Wiedergabeeinstellungen	Playback adjustments	5/7
5.3.1	Pegeleinstellen der Wiedergabeverstärker (FAST)	Level adjustment for reproduce amplifier (FAST)	5/8
5.3.2	Pegeleinstellen der Wiedergabeverstärker (SLOW)	Level adjustment for reproduce amplifier (SLOW)	5/8
5.3.3	Wiedergabekopf-Spalteinstellung (AZIMUT)	Azimuth adjustment for reproduce head	5/9
5.3.4	Wiedergabekopf-Spalteinstellung (AZIMUT)	Azimuth adjustment for reproduce head	5/9
5.3.5	Wiedergabefrequenzgang-Abgleich (FAST)	Balancing reproduction frequency response (FAST)	5/12
5.3.6	Wiedergabefrequenzgang-Abgleich (SLOW)	Balancing reproduction frequency response (SLOW)	5/12
5.4	Aufnahmeeinstellungen	Record adjustments	5/14
5.4.1	Kontrolle der Oszillatorfrequenz	Checking of oscillator frequency	5/14
5.4.2	Pegeleinstellen der Aufnahmeverstärker (FAST)	Level adjustment of record amplifier (FAST)	5/15
5.4.3	Pegeleinstellen der Aufnahmeverstärker (SLOW)	Level adjustment of record amplifier (SLOW)	5/16
5.4.4	Aufnahmekopf-Spalteinstellung (AZIMUT)	Record head azimuth adjustment	5/17
5.4.5	Vormagnetisierung	Tape bias	5/19
5.4.6	Vormagnetisierung (FAST)	Bias setting (FAST)	5/20
5.4.7	Vormagnetisierung (SLOW)	Bias setting (SLOW)	5/21
5.4.8	Aufnahmefrequenzgang Abgleich (FAST)	Balancing of recording frequency response (FAST)	5/22
5.4.9	Aufnahmefrequenzgang Abgleich (SLOW)	Balancing of recording frequency response (SLOW)	5/23
5.4.10	Frequenzgang "über Band" kontrollieren (FAST)	Frequency response "over all" (FAST)	5/24
5.4.11	Frequenzgang "über Band" kontrollieren (SLOW)	Frequency response "over all" (SLOW)	5/24
5.4.12	Einstellen der Übersprechkompensation	Adjustment of the crosstalk compensation	5/26
5.5	A80 R mit M		
5.5	A80 R mit mono - stereo Umschalter	A80 R equipped with mono - stereo switch	5/27
5.5.1	Pegeleinstellen des Aufnahme- und Wiedergabeverstärkers	Level adjustment of record/reproduce amplifier	5/27
5.6	A80 R VU-Meter Panel Version	A80 R VU-meter panel version	5/29
5.6.1	Allgemeines	General	5/29
5.6.2	Wiedergabeeinstellungen	Reproduce level adjustments	5/30
5.6.3	Positionieren der Pegelregler	Adjustment of level control	5/30
5.6.4	Pegeleinstellen der Wiedergabeverstärker (FAST)	Adjustment of reproduce amplifier level (FAST)	5/32
5.6.5	Pegeleinstellen der Wiedergabeverstärker (SLOW)	Adjustment of reproduce amplifier level (SLOW)	5/32
5.6.6	Wiedergabekopf-Spalteinstellung (AZIMUT)	Azimuth adjustment for reproduce head	5/34
5.6.7	Wiedergabekopf-Spalteinstellung (AZIMUT)	Azimuth adjustment for reproduce head	5/34
5.6.8	Wiedergabefrequenzgang Abgleich (FAST)	Adjustment of reproduce frequency response (FAST)	5/36
5.6.9	Wiedergabefrequenzgang Abgleich (SLOW)	Adjustment of reproduce frequency response (SLOW)	5/37
5.6.10	Aufnahmeeinstellungen	Adjustments for record functions	5/39
5.6.11	Pegeleinstellen der Aufnahmeverstärker (FAST)	Adjustment of record amplifier levels (FAST)	5/39
5.6.12	Pegeleinstellen der Aufnahmeverstärker (SLOW)	Adjustment of record amplifier levels (SLOW)	5/40
5.6.13	Aufnahmekopf-Spalteinstellung (AZIMUT)	Record head azimuth adjustment	5/41
5.6.14	Aufnahmekopf-Spalteinstellung (AZIMUT)	Record head azimuth adjustment	5/42
5.6.15	Vormagnetisierung	Tape bias	5/43
5.6.16	Aufnahmefrequenzgang Abgleich (FAST)	Adjustment of record frequency response (FAST)	5/47
5.6.17	Aufnahmefrequenzgang Abgleich (SLOW)	Adjustment of record frequency response (SLOW)	5/47
5.6.18	Frequenzgang "über Band" kontrollieren (FAST)	Checking of frequency response "over all" (FAST)	5/49
5.6.19	Frequenzgang "über Band" kontrollieren (SLOW)	Checking of frequency response "over all" (SLOW)	5/49
5.6.20	Einstellen der Übersprechkompensation	Adjustment of crosstalk compensation	5/51

SECTION 6 SCHEMATA (ALLGEMEIN)**SCHEMATICS (GENERAL)****SECTION 7 SCHEMATA (LAUFWERK)****SCHEMATICS (TAPE TRANSPORT CONTROL)****SECTION 8 SCHEMATA (AUDIO)****SCHEMATICS (AUDIO)****SECTION 9 SCHEMATA (ÄLTERE AUSFÜHRUNGEN)****SCHEMATICS (EARLIER VERSIONS)****SECTION 10 ERSATZTEILE****PARTS LIST**

WORLDWIDE DISTRIBUTION

Switzerland: STUDER INTERNATIONAL AG
 Althardstrasse 150
 CH-8105 Regensdorf

 Telephone: 01 840 29 60
 Telex 58489 stui ch

EUROPE

Austria: STUDER REVOX WIEN GES. M.B.H.
 Ludwiggasse 4
 A-1180 Wien

 Telephone: (02 00) 47 33 09 / 47 34 65
 Telex: 07/5275 studr a

Italy: STUDER ITALIANA
 Via G. Spontini, 3
 I-20131 Milano

 Telephone: 27 29 51
 Telex: 335230 audiom
 Cables: beppatomil milano

France: STUDER FRANCE S.A.R.L.
 12 - 14, rue Desnouettes
 F-75015 Paris

 Telephone: 533 58 58 +
 Telex: audifra 204744 f

United Kingdom: F.W.O. BAUCH LIMITED
 49 Theobald Street
 Boreham Wood, Herts WD6 4RZ

 Telephone: 01-953 00 91
 Telex: 27502 bauch g
 Cables: bauch borehamwood

AFRICA

Republic of South Africa: STUDER REVOX SOUTH AFRICA (PTY.) LTD
 P.O. Box 31282
 2nd Floor, Audward House, 30 Ameshoff St
 Braamfontein 2017 (Johannesburg)

 Telephone: 39-2126/27
 Telex: 4-22401
 Cables: revox hifi johannesburg

FAR EAST

Hong Kong: STUDER REVOX FAR EAST LTD
 Parklane Building, 5th Floor
 233 - 235 Queen's Road, Central
 Hong Kong B.C.C.

 Telephone: 5-459688, 5-459924, 5-441310
 Telex: 60185 srfel hx

Australia: SYNTEC INTERNATIONAL PTY LTD
 P.O. Box 165
 North Sidney
 Australia 2060

 Telephone: 4064557, 4064627
 Telex: 70570 syntec

Japan: KAWAMURA ELECTRICAL LABORATORY
 No. 34, Yurai-Cho
 Shinjuku-Ku
 Tokyo 162

 Telephone: (03) 260-0401
 Telex: j22748 zigzag
 Cables: zigzag tokyo

NORTH AND SOUTH AMERICA

Canada: STUDER REVOX CANADA LTD
 14, Banigan Drive
 Toronto 17, Ontario M4H 1E9

 Telephone: 423-2831
 Telex: 06-23310 studer tor

Brazil: CENTELEC
 Equipamentos e Sistemas Electronicos Ltd.
 Av. Ataulfo de Paiva 135/1710
 22440 Rio de Janeiro - RJ

 Telephone: 287 6198
 Telex: 2130842 cosl br

USA: STUDER REVOX AMERICA INC.
 1425 Elm Hill Pike
 Nashville, Tennessee 37210

 Telephone: 615-254-5651
 Telex: 065230/554453 studer nas

1. ALLGEMEINES

1.1 STUDER A80 R PROFESSIONELLES MAGNETTONGERÄT

Das STUDER A80 R Magnettongerät ist in Rundfunk-, Fernseh-, Film- und Tonstudios vielseitig verwendbar.

Wie bei allen Geräten der A80er Linie sind die Baugruppen übersichtlich und logisch gegliedert. Das Laufwerkchassis kann problemlos um 90° geschwenkt werden. Dadurch sind alle Baugruppen für allfällige Servicearbeiten leicht zugänglich.

1.1.1 Ausführungen der A80 R Magnettongeräte in Konsole

- Vollspur, 1/4" Band
- Vollspur, 1/4" Band mit Pilotton
- Stereo, 1/4" Band mit 0,75 mm oder 2 mm Trennspur
- Zweispur, 1/4" Band mit 2 mm Trennspur und Spurwahlschalter
- Stereo, 1/4" Band mit 0,75 mm Trennspur auf Mono-Betrieb umschaltbar.

1.1.2 Ausführungen mit Kontrolleinheit (VU-Panel)

- Vollspur, 1/4" Band
- Vollspur, 1/4" Band mit Pilotton
- Vollspur, 1/4" Band mit Pilotton und Nachsteuereinheit
- Stereo, 1/4" Band mit 0,75 mm oder 2 mm Trennspur
- Zweispur, 1/4" Band mit 2 mm Trennspur und Spurwahlschalter

Die Kontrolleinheit (VU-Panel) enthält:

- Anzeigeinstrumente (VU-Meter)
- Wiedergabe- und Aufnahmepegelkontrollen (Potentiometer RECORD- und REPRODUCE LEVEL)
- VU-Meter auf Vor-Hinterband umschaltbar (INPUT-REPRODUCE Schalter)
- Sicherung gegen irrtümliches Löschen (SAFE-READY Schalter)
- Über den Schalter TERMINATION ON-OFF kann der Ausgang mit 600 Ohm belastet werden
- Kalibriermöglichkeit der Anzeigeinstrumente für Leitungspegel (ab NAB-Operating Level) +4dBm, +6dBm, +8dBm
- Option für Pilottongeräte: komplette Nachsteuereinheit

1. GENERAL

1.1 STUDER A80 R PROFESSIONAL TAPE RECORDER

The STUDER A80 R is designed for a wide range of applications in broadcasting, TV, film and music studios.

Like all recorders of the A80 series the sub-assemblies are clearly arranged and the tape transport chassis can be tilted by 90°. Thereby all subassemblies are easily accessible for service works.

1.1.1 Console version of the A80 R tape recorder:

- fulltrack, 1/4" tape
- fulltrack, 1/4" tape, with pilot tone
- stereo, 1/4" tape, guard track 0.75 mm or 2 mm
- two track, 1/4" tape, with track selection switch, guard track 2 mm
- stereo, 1/4" tape, switchable to mono, guard track 0.75 mm

1.1.2 VU-meter panel version of the A80 R tape recorder:

- fulltrack, 1/4" tape
- fulltrack, 1/4" tape, with pilot tone
- fulltrack, 1/4" tape, with pilot tone and follow-up system
- stereo, 1/4" tape, guard track 0.75 mm or 2 mm
- two track, 1/4" tape, with track selection switch, guard track 2 mm

The VU-meter panel contains:

- VU-meters
- RECORD and REPRODUCE LEVEL controls
- source/tape monitoring of the VU-meters (INPUT/REPRODUCE switch)
- SAFE/READY switch, protection against inadvertent erasing
- the output can be terminated internally by 600 ohms (TERMINATION switch)
- the VU-meters can be calibrated for various line levels of +4dBm, +6dBm and +8dBm (over NAB operating level)
- follow-up system (optional, for pilot tone units only)

**1.2
TECHNISCHE DATEN****Bandgeschwindigkeit:**

76,2 cm/s (30ips) / 38,1 cm/s (15ips)
38,1 cm/s (15ips) / 19,05 cm/s (7.5ips)
19,05 cm/s (7.5ips) / 9,5 cm/s (3.75ips)

Geschwindigkeitsabweichung:

± 0,2 % (abgleichbar)

Bandschlupf:

max. 0,1 %

Bandspulen:

Dreizack, NAB und DIN, max. Ø 30 cm

Bandbreite:

6,35 mm (1/4")

Tonhöenschwankungen:

(DIN 45507/IEC 386)

Spitze bewertet

76,2 cm/s max. 0,04 %
38,1 cm/s max. 0,04 %
19,05 cm/s max. 0,06 %
9,5 cm/s max. 0,12 %

Bandzähler:

Genauigkeit ± 0,2 %
Echtwertanzeige

Zähleranzeige:

Mathematische und komplementäre Darstellung▲

Bandzug:

(einstellbar)
70 ... 100 p bei Wiedergabe und Umspulen

Bandzugmaximum:

(einstellbar)
500 p bei Start und Stop

Umspulzeit:

(einstellbar)
ca. 120 s für 1000 m Band

Eingänge:

symmetrisch, erdfrei
Impedanz 8 kOhm, 30 Hz ... 20 kHz

Eingangspegel:

max. 22 dBm

Ausgänge:

symmetrisch, erdfrei
Impedanz max. 30 Ohm, 30 Hz ... 20 kHz
Abschlusswiderstand min. 200 Ohm

Ausgangspegel:

max. 24 dBm (R_L = 600 Ohm)

Entzerrung:

CCIR oder NAB, wahlweise steckbar

**1.2
TECHNICAL DATA****Tape speed:**

30ips (76,2 cm/s) / 15ips (38,1 cm/s)
15ips (38,1 cm/s) / 7.5ips (19,05 cm/s)
7.5ips (19,05 cm/s) / 3.75ips (9,5 cm/s)

Nominal speed deviation:

± 0.2 % (adjustable)

Tape slip:

max. 0.1 %

Tape reels:

RETMA, NAB and DIN, max. Ø 30 cm

Tape width:

1/4" (6,35 mm)

Wow and flutter:

(DIN 45507/IEC 386)

weighted

30ips max. 0.04 %
15ips max. 0.04 %
7.5ips max. 0.06 %
3.75ips max. 0.12 %

Tape timer:

tolerance ± 0.2 %
real time indication

Timer read-out:

mathematical and complementary display
sequence▲

Tape tension:

(adjustable)
70 ... 100 p in playback and fast wind mode

Max. tape tension:

(adjustable)
500 p for start and stop functions

Rewind time:

(adjustable)
ca. 120 s for 1000 m

Inputs:

symmetrical, floating
impedance 8 kohms, 30 Hz ... 20 kHz

Input level:

max. 22dBm

Outputs:

symmetrical, floating
impedance max. 30 ohms, 30 Hz ... 20 kHz
terminating impedance min. 200 ohms

Output level:

max. 24dBm (R_L = 600 ohms)

Equalisation:

CCIR or NAB, selectiv switchable

Frequenzgang:

Aufnahme - Wiedergabe

76,2 cm/s	(30ips)	50Hz ... 20kHz	± 2dB
		60Hz ... 18kHz	± 1dB
38,1 cm/s	(15ips)	30Hz ... 18kHz	± 2dB
		60Hz ... 15kHz	± 1dB
19,05 cm/s	(7.5ips)	30Hz ... 15kHz	± 2dB
		60Hz ... 12kHz	± 1dB
9,5 cm/s	(3.75ips)	40Hz ... 10kHz	± 2dB
		60Hz ... 8kHz	± 1dB

Frequency response:

record-playback

30ips	(76,2 cm/s)	50Hz ... 20kHz	± 2dB
		60Hz ... 18kHz	± 1dB
15ips	(38,1 cm/s)	30Hz ... 18kHz	± 2dB
		60Hz ... 15kHz	± 1dB
7.5ips	(19,05 cm/s)	30Hz ... 15kHz	± 2dB
		60Hz ... 12kHz	± 1dB
3.75ips	(9,5 cm/s)	40Hz ... 10kHz	± 2dB
		60Hz ... 8kHz	± 1dB

Fremd- und Geräuschspannungsabstand:

Effektivwerte nach Bewertungsfilter

DIN 45405 1967

Aufnahme - Wiedergabe

Signal to noise ratio:

effective value, measure by DIN 45405 1967

record-playback

Entzerrung nach CCIR*

Vollspur, 6,35 mm Spurbreite (320 nWb/m)

cm/s 9,5 19,05 38,1 76,2

bewertet	55dB	58dB	61dB	61dB
unbewertet	55dB	58dB	61dB	61dB

Stereo, 2,75 mm Spurbreite (510 nWb/m)

bewertet	55dB	58dB	61dB	61dB
unbewertet	55dB	58dB	61dB	61dB

Zweispur, 2 mm Spurbreite (320 nWb/m)

bewertet	52dB	54dB	56dB	56dB
unbewertet	52dB	54dB	56dB	56dB

equalisation according to CCIR*

fulltrack, 1/4" track width (320 nWb/m)

3.75ips 7.5ips 15ips 30ips

weighted	55dB	58dB	61dB	61dB
unweighted	55dB	58dB	61dB	61dB

stereo, 2.75 mm track width (510 nWb/m)

weighted	55dB	58dB	61dB	61dB
unweighted	55dB	58dB	61dB	61dB

two track, 2 mm track width (320 nWb/m)

weighted	52dB	54dB	56dB	56dB
unweighted	52dB	54dB	56dB	56dB

Entzerrung nach NAB●

bezogen auf +6dB über 185 nWb/m

cm/s 9,5 19,05 38,1 76,2

Vollspur	63dB	65dB	65dB	67dB
----------	------	------	------	------

Stereo	60dB	62dB	62dB	64dB
--------	------	------	------	------

Zweispur	59dB	61dB	61dB	63dB
----------	------	------	------	------

Equalisation according to NAB●

referred to +6dB, 185 nWb/m

3.75ips 7.5ips 15ips 30ips

fulltrack	63dB	65dB	65dB	67dB
-----------	------	------	------	------

stereo	60dB	62dB	62dB	64dB
--------	------	------	------	------

two track	59dB	61dB	61dB	63dB
-----------	------	------	------	------

Klirrfaktor:

Aufnahme - Wiedergabe

Entzerrung nach CCIR*

cm/s 9,5 19,05 38,1 76,2

Bandfluss

320 nWb/m

max.	2 %	1 %	1 %	1 %
------	-----	-----	-----	-----

Bandfluss

510 nWb/m

max.	3 %	3 %	2 %	2 %
------	-----	-----	-----	-----

Distortion:

record-playback

Equalisation according to CCIR*

3.75ips 7.5ips 15ips 30ips

tape flux

320 nWb/m

max.	2 %	1 %	1 %	1 %
------	-----	-----	-----	-----

tape flux

510 nWb/m

max.	3 %	3 %	2 %	2 %
------	-----	-----	-----	-----

Entzerrung nach NAB●

Bandfluss

185 nWb/m

max.	1,5 %	1 %	1 %	1 %
------	-------	-----	-----	-----

Equalisation according to NAB●

tape flux

185 nWb/m

max.	1,5 %	1 %	1 %	1 %
------	-------	-----	-----	-----

Übersprechdämpfung, stereo:

min. 40dB, 50Hz ... 12kHz

Crosstalk rejection, stereo:

min. 40dB, 50Hz ... 12kHz

Löschdämpfung:

min. 75dB bei 1kHz

Erase efficiency:

min. 75dB at 1kHz

Löschfrequenz:

150kHz

Erase frequency:

150kHz

Vormagnetisierungsfrequenz:

150kHz

Bias frequency:

150kHz

Stromversorgung:100V...120V / 200V...240V \pm 10 % 50/60Hz**Leistungsaufnahme:**

max. 320VA

Umgebungstemperaturbereich:

+10°C...+40°C (50°F...104°F)

Gewicht:

95 kg netto (209 lbs)

Abmessungen:

Breite: 700 mm (27.6")
Tiefe: 600 mm (23.6")
Höhe: 840 mm (33.1") mit Lenkrollen
780 mm (30.7") mit Füßen
800 mm (31.5") mit Füßen
840 mm (33.1") mit Füßen
900 mm (35.5") mit Füßen
Panelhöhe: 260 mm (10.2")

Electric current supply:100V...120V / 200V...240V \pm 10 % 50/60Hz**Power consumption:**

max. 320VA

Ambient temperature:

+10°C...+40°C (50°F...104°F)

Weight:

net 95 kg (209 lbs)

Dimensions:

width: 700 mm (27.6")
depth: 600 mm (23.6")
height: 840 mm (33.1") with castors
780 mm (30.7") stationary
800 mm (31.5") stationary
840 mm (33.1") stationary
900 mm (35.5") stationary
Panel, height: 260 mm (10.2")

* gemessen mit AGFA PER 525 oder äquivalenter Bandtyp

● gemessen mit 3 M 206 oder äquivalentem Bandtyp

▲ komplementäre Darstellung ohne ZERO-LOCATOR Funktion

* measured with AGFA PER 525 or equivalent tape

● measured with 3M 206 or equivalent tape

▲ complementary indication without ZERO-LOCATOR function

ABMESSUNGEN

DIMENSIONS

A80 R STANDARD VERSION IN CONSOLE

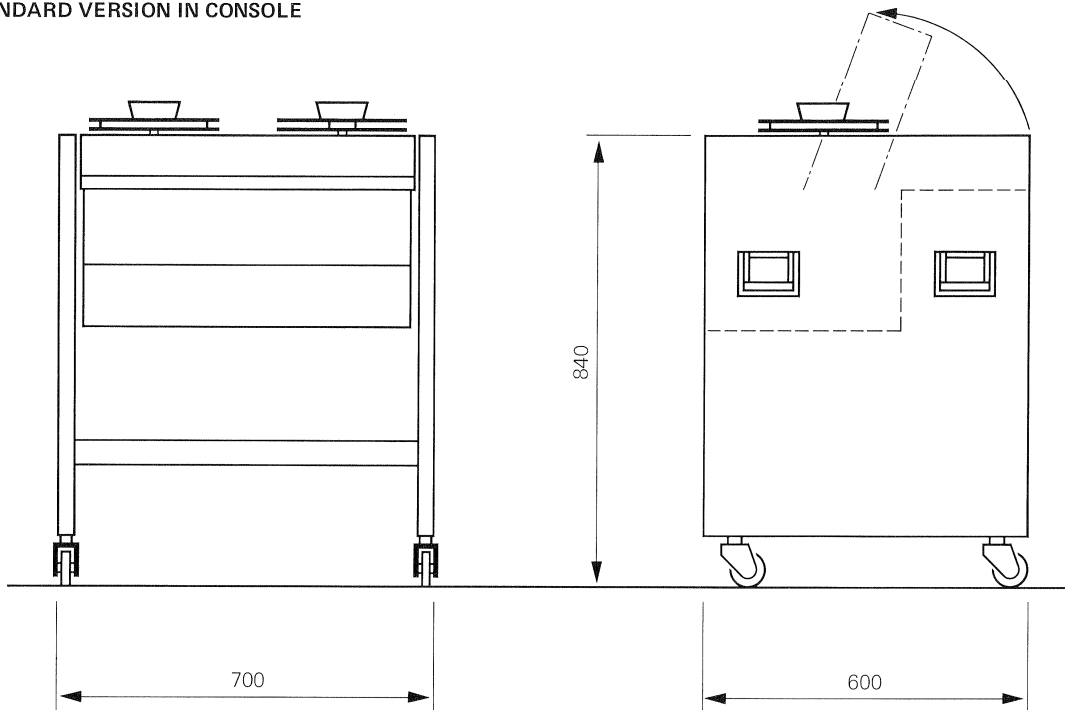

A80 R VU-PANEL IN CONSOLE

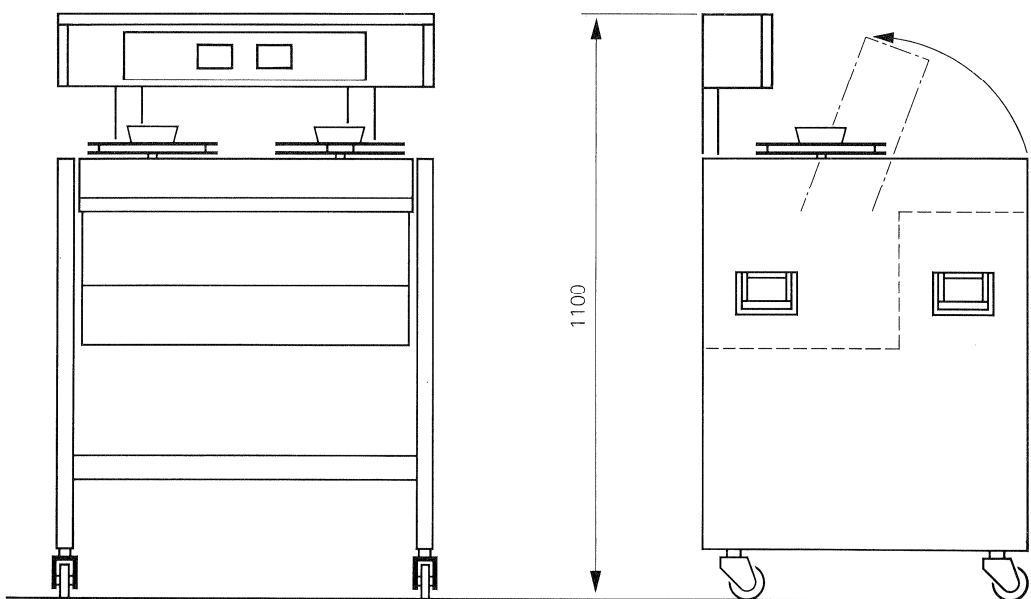

DRUCKTASTENEINHEIT

PUSH BUTTON AND COUNTER MODULE

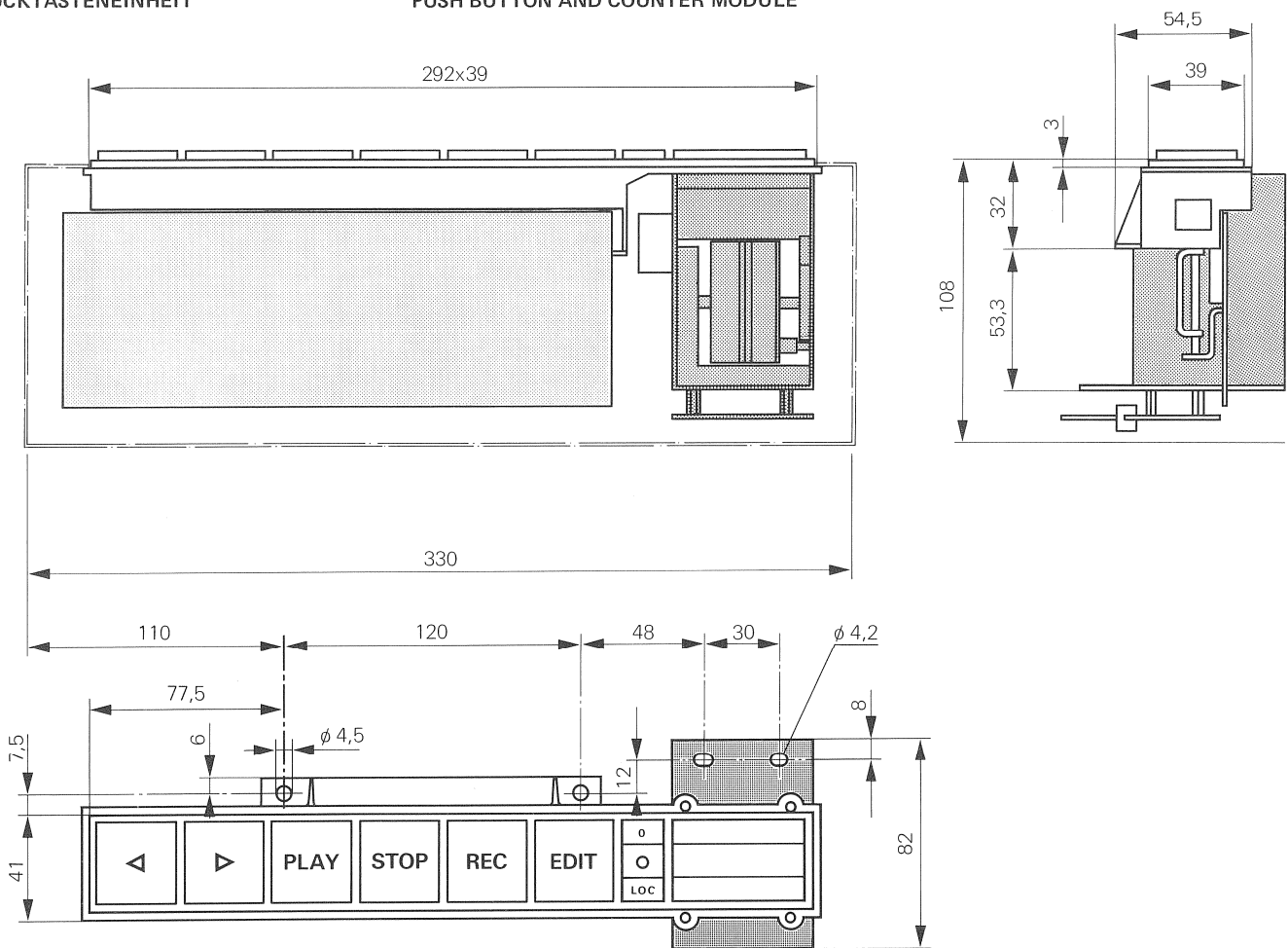

2. INBETRIEBNAHME / BEDIENUNG

2. PUTTING INTO OPERATION / OPERATING INSTRUCTIONS

2.1 INBETRIEBNAHME DES GERÄTES

2.1 PUTTING INTO OPERATION

2.1.1 Kontrollen vor Inbetriebnahme

2.1.1 Checks prior to initial operation

- Rückwand öffnen und Spannungswähler kontrollieren (Fig. 2.1/2.2).
- Kontrollieren, ob sich beim Transport keine Steckverbindung gelockert hat.
- Verdrahtung der Phasenschieberkondensatoren kontrollieren (siehe Fig. 2.3).
- Rückwand schliessen.

- Open rear panel and check voltage selector (Fig. 2.1/2.2).
- Check that none of the plug connections have become loose during shipment.
- Check wiring of phase-shifting capacitor (see Fig. 2.3)
- Reclose rear panel.

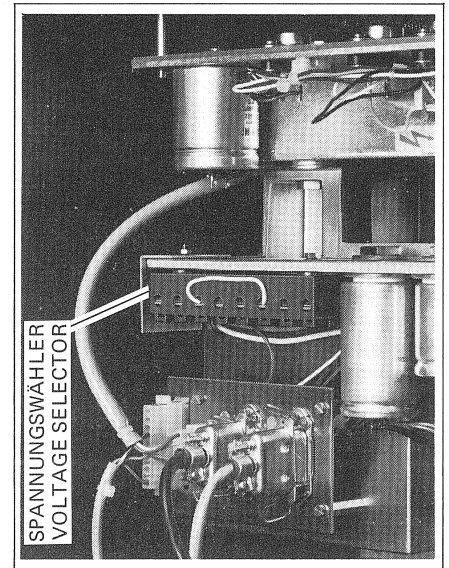

Fig. 2.1

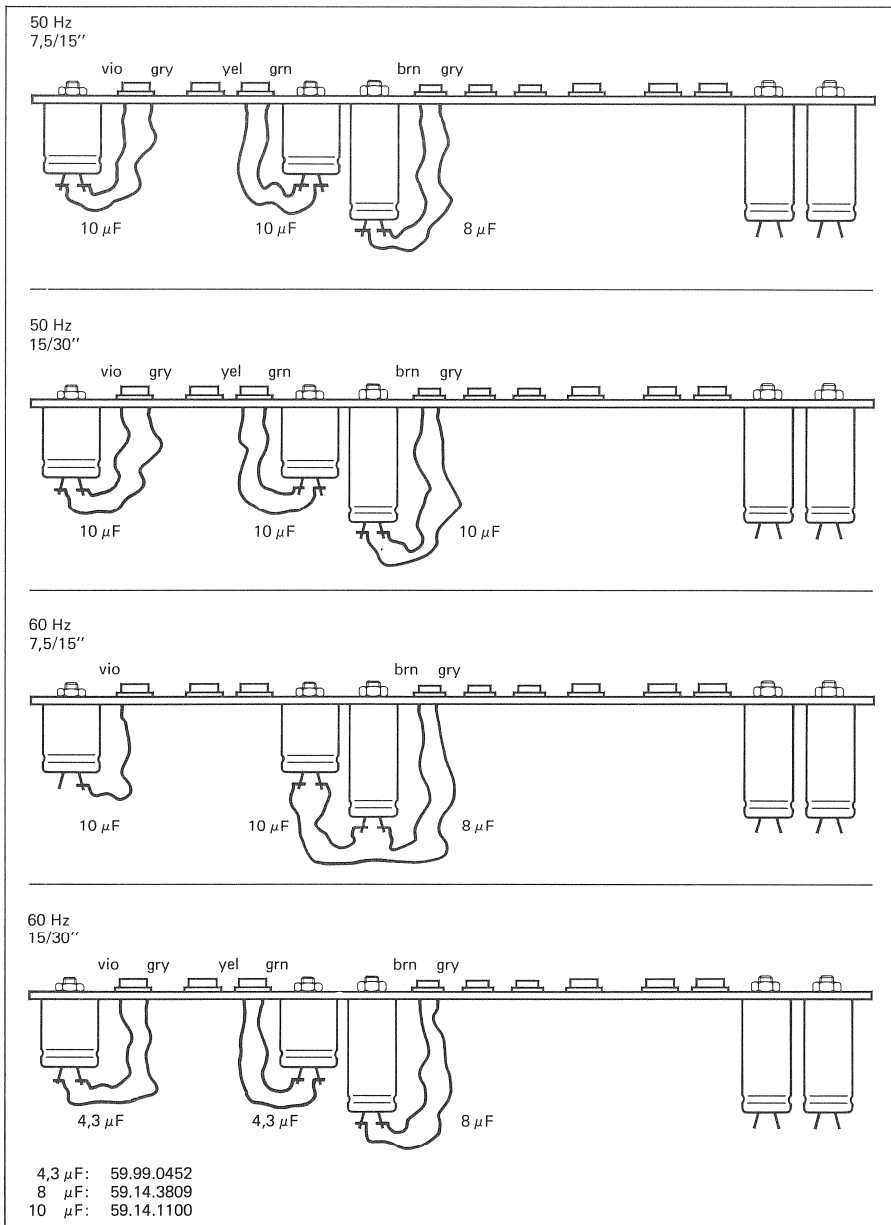

Fig. 2.3

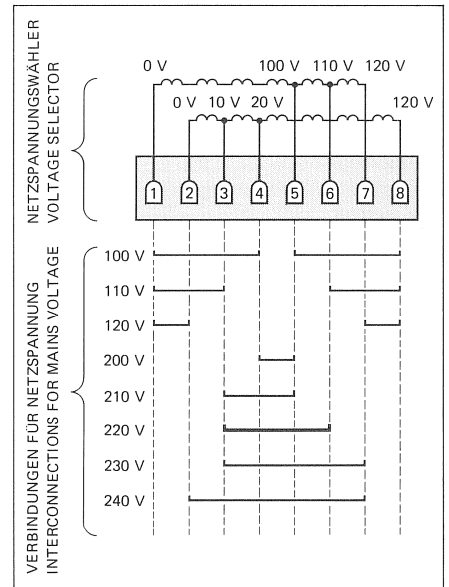

Fig. 2.2

2.1.2 Erdung

Die Geräte-Erde kann wahlweise auf Studio-Erde (GROUND POST) oder Netz-Erde (MAINS GROUND) geschaltet werden. Es wird empfohlen auf Studio-Erde zu schalten; der Anschluss erfolgt an der Bananenbuchse (A) (Fig. 2.4).

- (A) Erdanschluss (Bananenbuchse)
- (B) Erdschiene
- (C) Netzsicherung
- (D) Netzanschluss

2.1.3 Funktionsprüfung

Laufwerk:

- Mit dem Wählen der Bandgeschwindigkeit, Gerät einschalten.
- Aufleuchten der Taste STOP zeigt Betriebsbereitschaft an.

Anmerkung:

Die Bandgeschwindigkeit darf auch bei laufendem Bandtransport umgeschaltet werden.

2.1.4 Adapter für 1/4" Geräte

1/4" Geräte sind konzipiert für den Einsatz von NAB-Spulen oder Kernen, DIN-Kernen und Dreizackspulen (25/18/13 cm). Dazu müssen die Adapter gemäß Fig. 2.5 eingesetzt werden.

Wird eine NAB-Spule oder ein NAB-Kern verwendet, so ist ein NAB-Kernadapter 1.013.330 auf den Dreizackadapter (RETMA) zu stecken. Zum Arretieren, den zentralen Dreizackstift anheben und um 60° drehen.

Den Oberteil des schwarzen NAB-Kernadapters so drehen (Gegenuhrzeigersinn), dass die drei Nocken übereinanderstehen; Spule aufstecken und durch eine 60°-Drehung des Oberteils die Spule festklemmen.

Werden freitragende Bandwickel verwendet, so ist vor dem Einsetzen des NAB-Kernadapters der Metallteller 1.013.328 aufzulegen. Dieser tritt anstelle eines unteren Flansches und verhindert ein Herabfallen des Bandes.

2.1.2 Grounding

The equipment can be grounded by manually connecting the ground either to studio earth (GROUND POST) or to MAINS GROUND. It is recommended to operate the unit in GROUND POST position. Connection is established via banana socket (A), (Fig. 2.4).

- (A) Ground connection (banana socket)
- (B) Ground bus bar
- (C) Mains fuse
- (D) Mains plug

2.1.3 Function test

Tape deck:

- Switch on machine by selecting desired tape speed.
- When STOP indicator lights up, machine signals that it is ready.

Note:

Tape speeds may be changed even while machine is running.

2.1.4 Adaptors for 1/4" tape units

1/4" units are designed to operate with NAB reels or cores, DIN cores and three-prong cores (25/18/13 cm). Suitable adaptors must be mounted according to Fig. 2.5

If an NAB reel or NAB core is used, an NAB core adaptor 1.013.330 must be mounted on the three-prong adaptor (RETMA). To lock the adaptor, the three-prong center pin is lifted and rotated by 60°

The upper segment of the black NAB core adaptor is rotated counter-clockwise until the three cams are aligned. Mount reel and turn upper section by 60° to lock reel in place.

If self-supporting reels are used, the metal plate 1.013.328 must be mounted prior to inserting the NAB core adaptor. The plate takes the place of the lower flange and prevents the tape from dropping off.

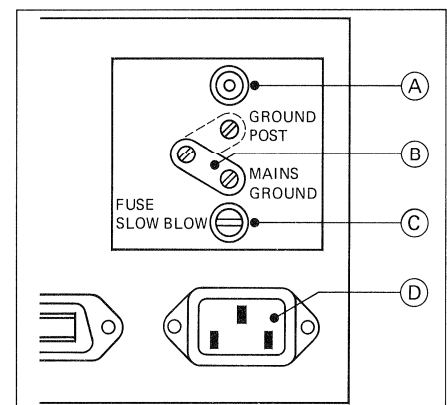

Fig. 2.4

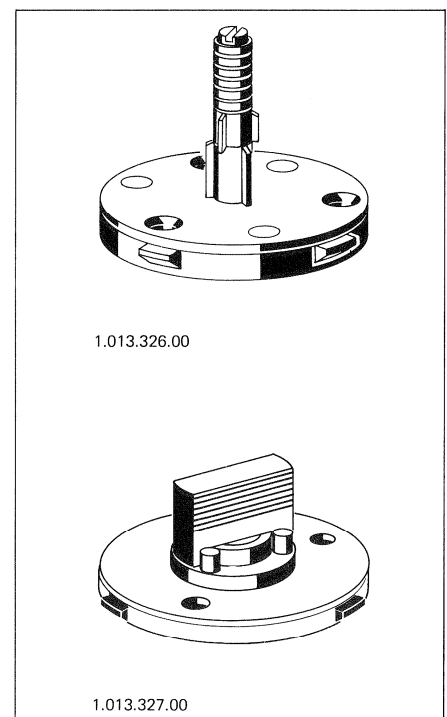

Fig. 2.5

**2.1.5
NF-Anschlüsse**

Verbindungen für Aufnahme und Wiedergabe anschliessen. Siehe Fig. 2.6

**2.1.6
Pegel**

Die Verstärker sind auf die im Prüfprotokoll angegebenen Werte eingestellt.
Für weitere Angaben siehe Technische Daten.

**2.1.5
AF connections**

Establish connections for recording and playback equipment. See Fig 2.6

**2.1.6
Level**

The amplifiers have been calibrated to the values indicated in the test protocol.
For further information see technical specifications.

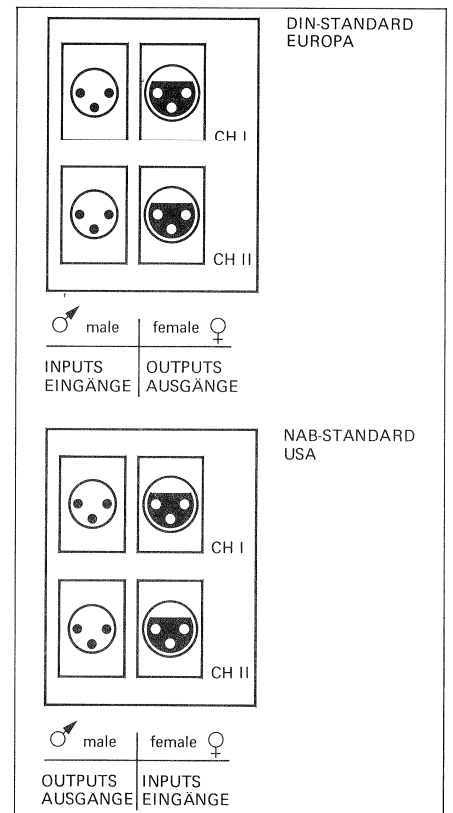

Fig. 2.6

**2.2
BEDIENUNG**

**2.2.1
Drucktasten**

Wiedergabe:

Taste PLAY (3) drücken, die Andruckrollen fahren in PLAY-Position.

Aufnahme:

Tasten PLAY (3) und REC (5) gleichzeitig drücken, die Andruckrollen fahren in PLAY-Position.
Die Maschine geht auf Aufnahmebetrieb.

Schneller Vorlauf:

Taste (2) drücken.

Schneller Rücklauf:

Taste (1) drücken.

Beim Übergang von einer Lauffunktion in eine andere, braucht die Taste STOP nicht gedrückt zu werden (Ausnahme EDIT); die Steuerung speichert die eingetasteten Befehle bis das Band steht. Der Übergang in die nächste Funktion erfolgt automatisch, sobald das Band stillsteht.

**2.2
OPERATION**

**2.2.1
Push buttons**

Playback:

Depress PLAY (3). The pinch-rollers move into PLAY position.

Record:

Simultaneously depress PLAY (3) and REC (5). The pinch-rollers move into PLAY position. The unit is ready for record operations.

Fast forward:

Depress key (2).

Fast rewind:

Depress key (1).

It is not necessary to depress the STOP key when switching from one tape function to another (except for EDIT). The control system stores the selected function until the tape has come to a stop. The selected function is initiated automatically after the tape has stopped.

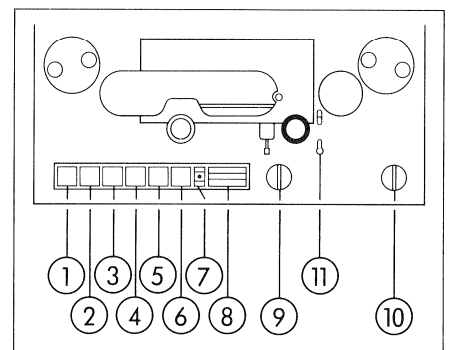

Fig. 2.7

2.2.2**Bandzähler**

Der Bandzähler zeigt für beide Bandgeschwindigkeiten die wirkliche Zeit an.

Sekunden	2 Stellen
Minuten	2 Stellen
Stunden	1 Stelle

Bei Erreichen des Bandendes stoppt der Bandzähler automatisch.

2.2.2**Tape counter**

For both tape speeds, the counter indicates the true elapsed time.

Seconds:	2 digits
Minutes:	2 digits
Hours:	1 digit

The counter stops automatically when reaching the end of the tape.

2.2.3**Elektronischer Bandzähler**

Die Zählung der reinen Bandlaufzeit erfolgt sechsstellig bei beiden Bandgeschwindigkeiten in Stunden, Minuten, Sekunden. Die Darstellung ist fünfstellig durch 7-Segment LED-Anzeigeeinheiten. Die Wahl der Darstellungsart erfolgt durch Positionierung eines Brückensteckers (Decoder Print 1.228.811).

Mathematische Darstellung:

0.00.01/0.00.00/–00.01

Bei negativen Zeiten wird die Stundenziffer in ein Minuszeichen verwandelt.

Komplementäre Darstellung:

0.00.01/0.00.00/9.59.59

Negative Zeiten werden durch das Komplement dargestellt.

2.2.3**Electronic tape counter**

The 5-position, seven-segment LED display shows the net elapsed time for both tape speeds. The display mode can be selected by positioning the bridging connector accordingly (decoder print 1.228.811).

Mathematical representation:

0.00.01/0.00.00/–00.01

For negative times the hours digit is converted to a minus sign.

Complementary representation:

0.00.01/0.00.00/9.59.59

Negative times are shown by a complement.

2.2.4**Taste EDIT (6)**

Die EDIT-Funktion wird nur ausgeführt, wenn das Band stillsteht. Durch Drücken der Taste EDIT (6) fahren die Andruckrollen in EDIT-Position, gleichzeitig werden die Bandzugwaagen blockiert. Das Band liegt auf den Tonköpfen auf. In dieser Position können die Bandwickel von Hand gedreht werden (suchen einer Schnittstelle).

Wird die Taste EDIT (6) während dem schnellen Umspulen betätigt, so fahren die Andruckrollen in die EDIT-Position und verbleiben in derselben, bis die Taste EDIT wieder losgelassen wird (Zwischenhören). Bei schnellem Umspulen kann der gleiche Effekt auch durch Betätigen des Schiebers (11) erreicht werden.

2.2.4**EDIT key (6)**

The EDIT function can only be performed while the tape is stationary. After depressing the EDIT key (6), the pinch rollers move to the EDIT position. The tape tension sensors are automatically blocked. The tape touches the heads. In this position, the tape reels can be rotated manually (to find the desired cutting position). If the EDIT key (6) is depressed during fast wind functions, the pinch rollers move into EDIT position and stay there until the EDIT key is released (cueing). During fast wind, the same effect can be obtained by operating the slider (11).

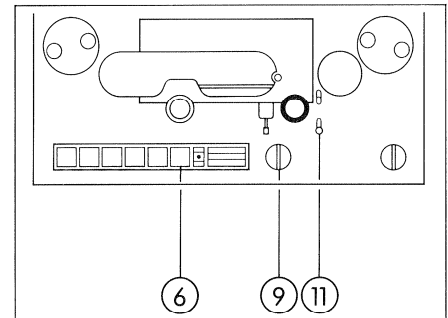

Fig. 2.7

2.2.5**Reglerknopf EDIT (für variables Umspulen)**

Das Suchen einer Schnittstelle kann auch motorgetrieben erfolgen (CUTAUT).

Bei stehendem Band Taste EDIT drücken. Den Reglerknopf EDIT (9) für die gewünschte Laufrichtung im Uhr- oder Gegenuhreigersinn drehen. Die Laufgeschwindigkeit ist abhängig vom Drehwinkel. Sobald am Reglerknopf EDIT (9) gedreht wird, ist die Blockierung der Bandzugwaagen aufgehoben (geregelter Bandzug; bei

2.2.5**EDIT control (for variable winding)**

Motorized search for a cutting position is also possible (CUTAUT).

Press EDIT key while tape is stopped. Turn EDIT control (9) in the desired tape direction (clockwise or counter-clockwise). The tape speed is proportional to the angular deflection of the control knob. As soon as the EDIT control leaves its neutral position, the tape tension sensors are unlocked (controlled tape ten-

11 FAD-1	Löst zusammen mit FAD-2 den Reglerstart aus. 24 V DC, beliebige Polarität.	11 FAD-1	initiates fader start together with FAD-2. 24V DC, any polarity
12 +24.0 V	+ 24 V Speisung, wird meist angewendet für die Reglerstart-Auslösung bei interner 24-V-Speisung.	12 + 24.0 V	+ 24 V supply. Generally used for fader start activation when operating with local 24 V power
13 Y-MOVE-1	schaltet auf 0 V bei Bandbewegung.	13 Y-MOVE-1	switches to 0 V during tape motions
14 Y-MOVE-D	schaltet auf 0 V bei Bandbewegung in Rückwärtsrichtung sowie bei Überschreiten von 110 % der gewählten Bandgeschwindigkeit in Vorwärtsrichtung.	14 Y-MOVE-D	switches to 0 V during tape motions in reverse direction and when exceeding 110% of the tape selected speed in a forward direction
15 -5.8 V	-5,8 V Speisung.	15 - 5.8 V	- 5.8 V supply
16 Y-REVRS	schaltet auf 0 V bei Bandbewegung rückwärts.	16 Y-REVRS	switches to 0 V during tape motion in reverse direction
17 Y-FORW	schaltet auf 0 V bei Bandbewegung vorwärts.	17 Y-FORW	switches to 0 V during tape motion in forward direction
18 +24.0 V	+ 24 V Speisung für externen Zähler.	18 + 24.0 V	+ 24 V supply for external counter
19 LOC-IN	Freigabeleitung (Rückleitung) für alle externen Taster.	19 LOC-IN	Release line (feedback line) for all external keys
20 S-REW	Tastenleitung Rückwickeln.	20 S-REW	command line, rewind (fast)
21 S-FORW	Tastenleitung Vorwickeln.	21 S-FORW	command line, forward wind (fast)
22 S-REPR	Tastenleitung Betrieb.	22 S-REPR	command line START
23 S-STOP	Tastenleitung Stopp.	23 S-STOP	command line STOP
24 S-REC	Tastenleitung Aufnahme.	24 S-REC	command line RECORD
25 S-CUT	Tastenleitung Edit.	25 S-CUT	command line EDIT
26 S-MONO*	Tastenleitung Mono-Betrieb.	26 S-MONO*	command line MONO
27 Y-HIGH	schaltet auf 0 V bei der hohen Bandgeschwindigkeit.	27 Y-HIGH	switches to 0 V when selecting the fast tape speed
28 S-ZLOCAT	Tastenleitung: Rücklauf auf 0	28 S-ZLOCAT	command line: rewind to zero
29 FAD-2	Löst zusammen mit FAD-1 den Reglerstart aus. 24 V DC, beliebige Polarität.	29 FAD-2	Initiates fader start together with FAD-1. 24V DC, any polarity
30 +0.0	0,0 V (Masse)	30 + 0.0	0.0 V (ground)
31 +0-TYPE	nicht verbunden, reservierter Anschluss.	31 + 0-TYPE	not connected, spare connection
32 +5.8 V	+ 5,8 V Speisung	32 + 5.8 V	+ 5.8 V supply
33 K-RESET	schaltet auf 0 V bei Betätigung der Nullstelltaste des Zählers. Löst bei Schaltung auf 0 V eine Nullsetzung des Zählers aus.	33 K-RESET	switches to 0 V when activating the zero reset key of the counter. The counter is reset to zero when signal changes to 0 V.
34 Y-CLK	symmetrisches Rechtecksignal von 2 Hz bei beiden Bandgeschwindigkeiten (offener Kollektor). Invers zu Y-ICLK.	34 Y-CLK	symmetrical square-wave signal, 2 Hz with both tape speeds (open collector). Inverse to Y-ICLK.
35 Y-ICLK	Invers zu Y-CLK.	35 Y-ICLK	Inverse to Y-CLK.
36 +0.0	0,0 V (Masse).	36 + 0.0	0.0 V (ground)

*Diese Signale sind nur vorhanden, wenn das Laufwerk mit einem Mono/Stereo Schalter ausgerüstet ist.

* These signals are only available for units equipped with mono/stereo switching capabilities.

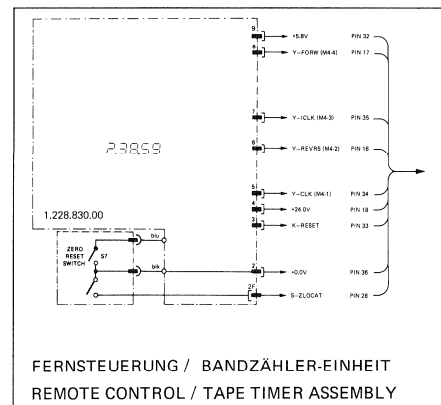

Fig. 2.10

FERNSTEUERUNG / BANDZÄHLER-EINHEIT
REMOTE CONTROL / TAPE TIMER ASSEMBLY

Die mit Y-... bezeichneten Signale werden durch einen Schalttransistor auf 0 V geschaltet (active low, open collector).

$I_{max} = 300 \text{ mA}$
 $U_{max} = 28 \text{ V}$

Im Normalfall muss ein Arbeitswiderstand auf + 24 V vorgesehen werden. Die Höhe des positiven Potentials bei nicht leitendem Transistor ist unbestimmt.

The signals labelled Y-... are switched to 0 V (active low, open collector) by a switching transistor.

$I_{max} = 300 \text{ mA}$
 $V_{max} = 28 \text{ V}$

Normally, a load impedance at + 24 V must be available. The level of the positive potential with the transistor blocked is not determined.

2.3.1 Anschluss CAPSTAN SPEED CONTROL

Der 14-pol-Steckanschluss CAPSTAN SPEED CONTROL ermöglicht den Anschluss von externen Tonmotor-Nachsteuerschaltungen. Für die Steckerbelegung, siehe Fig. 2.11.

Zu Kontrollzwecken kann die Servo-Frequenz der Tonmotor-Regelung an den Stiften 14 (YAC 3-2, Masse) und 7 (YAC 3-1) abgegriffen und mit einem Digital-Zähler gemessen werden. Die Frequenz beträgt bei normaler Soll-Bandgeschwindigkeit 800 Hz; dabei ist zu beachten, dass diese Frequenz für beide Geschwindigkeiten 38 cm/s (15 ips) und 19 cm/s (7.5 ips) identisch ist.

Nachsteuerschaltung ± 3 % mit Potentiometer: Gemäss Fig. 2.12 ein lineares Potentiometer, Wert 1 kOhm anschliessen. Diese Schaltung ermöglicht eine Geschwindigkeits-Regelung von ca. ± 3 %. Zur Erzielung einer besseren Auflösung ist die Anwendung eines 10 : 1 Potentiometers empfohlen. Die Nachsteuerung ist möglich mit den Tonmotor-Steuerprints 1.080.374 und 1.080.376.

Nachsteuerschaltung ± 7 Halbtöne mit Potentiometer:

Gemäss Fig. 2.13 ein lineares Potentiometer, Wert 10 kohm, mit Widerständen 4,64 kohm und 14,3 kohm in Serie anschliessen. Diese Schaltung ermöglicht eine Geschwindigkeits-Regelung von ± 7 Halbtönen. Zur Erzielung einer besseren Auflösung ist auch hier die Anwendung eines 10 : 1 Potentiometers empfohlen. Die Nachsteuerung ist nur möglich mit dem Tonmotor-Steuerprint 1.080.374.

Für die verschiedenen Kapstansteuerungen gelten folgende Frequenzen:

1.080.372	15/30 ips	1600 Hz
1.080.374	7,5/15 ips	800 Hz
1.080.377	3,75/7,5 ips	400 Hz

2.3.1 Connector CAPSTAN SPEED CONTROL

The 14-pin connector CAPSTAN SPEED CONTROL allows connection of external capstan motor readjustment circuits. For layout of pins see Fig. 2.11

For control purposes, the servo frequency of the capstan motor control is available at pins 14 (YAC 3-2, ground) and 7 (YAC 3-1) for input to a digital counter. At nominal tape speed the frequency is 800 Hz. It should be noted that this frequency is identical for both tape speeds.

Speed readjustment ± 3 % with potentiometer:

As shown in Fig. 2.12, a 1 kohms linear potentiometer may be connected. This circuit allows speed regulation of approx. ± 3 %. To improve resolution, a 10:1 potentiometer is recommended. Readjustment is accomplished through the capstan motor PCBs 1.080.374 and 1.080.376.

Readjustment ± 7 half notes with potentiometer

As shown in fig. 2.13, a 10kohms linear potentiometer with resistors 4.64 kohms and 14.3 kohms are serially connected. This setup permits speed adjustment resulting in pitch variation of ± 7 half notes. To improve resolution, a 10:1 potentiometer is recommended. Readjustment is only possible via capstan PCB 1.080.374.

The following frequencies apply to the capstan control:

1.080.372	15/30 ips	1600 Hz
1.080.374	7.5/15 ips	800 Hz
1.080.377	3.75/7.5 ips	400 Hz

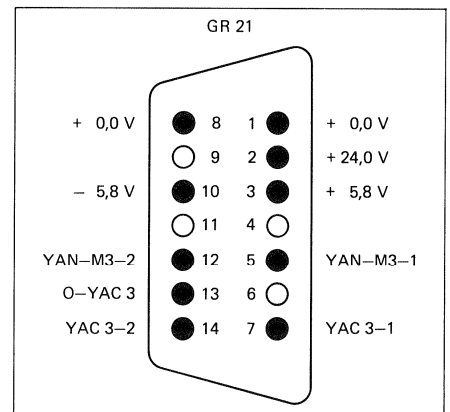

Fig. 2.11

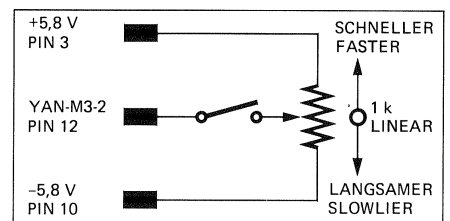

Fig. 2.12

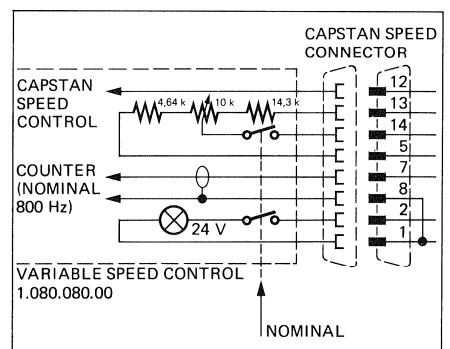

Fig. 2.13

Anschluss	Signal	Funktion	Pin	Signal	Function
1	+0.0	0,0 V (Masse)	1	+ 0.0	0.0 V (ground)
2	+24.0 V	+ 24 V Speisung	2	+ 24 V	+ 24 V supply
3	+5.8 V	+ 5,8 V Speisung	3	+ 5.8 V	+ 5.8 V supply
4	leer		4	blank	
5	(YAN-M3-1)	+ 0,5 V (Diodenspannung) benötigt zur temperaturkompensierten Nachsteuerung bei 1.080.376.	5	(YAN-M3-1)	+ 0.5 V (diode voltage) required for temperature compensated readjustment on 1.080.376
6	leer		6	blank	
7	(YAC3-1)	1.080.376: symm. Rechtecksignal 20 V. $Z_q = 10 \text{ k}\Omega$ in Serie mit 10 nF. 1.080.374: symm. Rechtecksignal 11 V. $Z_q = 22 \text{ k}\Omega$.	7	(YAC3-1)	1.080.376: symmetrical square-wave signal 20 V. $Z_q = 10 \text{ kohms}$ in series with 10 nF. 1.080.374: symmetrical square-wave signal 11 V. $Z_q = 22 \text{ kohms}$
8	+0.0	0,0 V (Masse)	8	+ 0.0	0.0 V (ground)
9	leer		9	blank	
10	-5.8 V	-5,8 V Speisung	10	- 5.8 V	- 5.8 V supply
11	leer		11	blank	
12	(YAN-M3-2)	$R_i > 2 \text{ k}\Omega$.	12	(YAN-M3-2)	$R_i > 2 \text{ kohms}$
13	0-YAC3	0,0 V	13	0-YAC3	0.0 V
14	YAC3-2	0,0 V bei Print 1.080.376. Nachsteuerspannung 7,5 V $\pm 1,5 \text{ V}$ für ± 7 Halbtöne bei Print 1.080.374 und 1.081.376.	14	YAC3-2	0.0 V with PCB 1.080.376 Readjustment voltage 7.5 V $\pm 1.5 \text{ V}$ for ± 7 half notes with PCBs 1.080.374 and 1.081.376.

2.4 PAPIERKORBBERIEB

Umstecken des Verbindungssteckers auf der Wickelmotor-Steckkarte 1.080.383 (siehe Schaltbild und Belegungsplan) ermöglicht den Papierkorbbetrieb der Tonbandmaschine. Durch Drücken der Stopptaste während dem Rückspulen im Papierkorbbetrieb wird der linke Wickelmotor gebremst.

2.4 WASTE PAPER BASKET MODE

By replugging the connector on the spooling motor circuit board 1.080.383 (see circuit diagram and component layout), the tape unit can operate in waste-paper basket mode. When the stop key is depressed during rewinding in waste-paper mode, the left-hand spooling motor is blocked.

3. AUSBAU DER BAUGRUPPEN

Achtung:

Vor Beginn der Service-Arbeiten ist das Gerät von der Netzspannung zu trennen (Netzstecker ziehen).

3.1 ALLGEMEINES

Für Servicearbeiten kann das gesamte A80-Laufwerk im Betriebszustand um 90° geschwenkt werden. Die Baugruppen sind leicht zugänglich; alle Aggregate können durch mehrpolige Steckverbindungen abgetrennt und ohne Spezialwerkzeuge ausgebaut werden.

Oszillator, Spannungs-Stabilisator und Logik-Schaltkreise sind auf Steckkarten gleicher Größe vereinigt und unter dem Laufwerk untergebracht (CONTROL UNIT). Alle Testpunkte und Einstellregler sind von vorne zugänglich.

Notwendige Werkzeuge:
Innensechskant-Schlüsselsatz 1,27 mm bis 6 mm

Zum Kippen des Laufwerkes, Rändelschraube vorne, unten lösen.

3.1.1 Abdeckbleche des Laufwerkes abnehmen

hinteres Abdeckblech:
– 6 Schrauben lösen, hinten anheben und nach hinten ausfahren.
vorderes Abdeckblech:
– 2 Schrauben oben, 2 Schrauben vorne lösen.
– Abdeckblech über die Bedienungsknöpfe anheben und nach vorne ausfahren.
unteres Abdeckblech vorne:
– Rändelschraube des Klappdeckels lösen
– Klappdeckel öffnen
– 4 Schrauben lösen (unverlierbar)
unteres Abdeckblech hinten:
– 6 Schrauben lösen.

3.1.2 Tonmotor ausbauen

– Mehrfachstecker unten lösen
– 4 Schrauben von unten lösen
– Tonmotor vorsichtig nach unten ausfahren.

3. REMOVAL OF ASSEMBLIES

Caution:

AC power must be disconnected (disconnect AC plug) before starting service work.

3.1 GENERAL

To facilitate service work, the complete tape drive system of the A80 can be tilted by 90° while still fully assembled. The assemblies thereby become easily accessible. All assemblies can be disconnected by multipoint connectors and their removal does not require any tools.

Oscillator, voltage stabilizer and logic circuits are contained on plug-in circuit boards of identical size. The boards are mounted below the drive assembly (CONTROL UNIT). All test-points and adjustable potentiometers are accessible from the front.

Tool requirements:
Allenhead key set 1.27 mm to 6 mm.

To tilt the drive unit, loosen knurled screws located at front bottom.

3.1.1 Removal of cover plates from tape drive unit:

Rear cover plate:
– Loosen 6 screws, lift back end and slide out towards rear.
Front cover plate:
– Loosen 2 screws on top, 2 at front.
– Lift cover plate past operating elements and slide out forward.
Lower cover plate, front:
– Loosen knurled screws of hinged cover.
– Open hinged cover
– Loosen 4 captive screws.
Lower cover plate, rear:
– Loosen 6 screws.

3.1.2 Removal of capstan motor

– Disconnect multipoint connector
– Loosen 4 screws from below
– Carefully remove capstan motor by sliding downward.

3.1.3**Wickelmotoren mit Bremsaggregat ausbauen**

- 2 Mehrfachstecker lösen (Chassis Oberseite)
- 4 Schrauben von oben lösen
- Wickelmotor vorsichtig nach oben ausfahren.

3.1.4**Kopfträger ausbauen**

- 3 Schrauben von oben durch den Kopfträgerdeckel lösen (es ist nicht nötig, diese Schrauben zu entfernen)
- Kopfträger vorsichtig nach oben ausfahren und nicht an der Tonmotorachse anschlagen.

Den Kopfträger nicht umdrehen, sonst fallen die Befestigungsschrauben heraus.

3.1.5**Andruckaggregat ausbauen**

- Kopfträger ausbauen (Kap. 3.1.4)
- Mehrfachstecker rechte Seite lösen
- 3 Schrauben von oben lösen
- Andruckaggregat vorsichtig nach oben ausfahren.

3.1.6**Federdämpfungselemente ausbauen**

- Rollenteller der Bandzugwaage ausbauen (1 Schraube lösen)
- Kupplung zum Federgestänge lösen (2 Schrauben)
- 1 Schraube von Dämpfungselement lösen
- Dämpfungselement vorsichtig drehen und den Sprengring an der Kupplung entfernen
- 3 Schrauben von Dämpfungsplatte lösen und Federdämpfungselement ausfahren.

3.1.7**Bandzugwaagen ausbauen**

- Rollenteller der Bandzugwaage ausbauen, 1 Schraube lösen
- Federdämpfungselement ausbauen (siehe 3.1.6)
- Mehrfachstecker lösen (unten)
- 3 Schrauben von oben lösen
- Bandzugwaage vorsichtig nach oben ausfahren.

3.1.3**Removal of spooling motor with brake unit**

- Disconnect 2 multipoint connectors (top of chassis).
- Loosen 4 screws from top.
- Carefully slide out spooling motor by lifting through the top.

3.1.4**Removal of head block assembly**

- Loosen 3 screws from top through the head block cover (it is not necessary to remove the screws).
- Carefully lift out head block assembly.

Do not twist head block assembly, otherwise the screws will fall off.

3.1.5**Removal of pinchroller assembly**

- Remove headblock assembly (see chap. 3.1.4).
- Disconnect multipoint connector on right side.
- Loose 3 screws from top.
- Carefully lift out pinchroller assembly.

3.1.6**Removal of spring and damping units.**

- Remove roller plate of tape tension sensor (loosen 1 screw).
- Disconnect clutch to spring and damping unit (unscrew 2 screws).
- Loosen 1 screw of damping unit.
- Carefully twist damping unit and remove circlip at clutch.
- Loosen 3 screws from plate and slide out spring and damping unit.

3.1.7**Removal of tape tension sensor**

- Dismantle roller plate of tape tension sensor, loosen 1 screw.
- Dismantle spring and damping unit (see 3.1.6)
- Disconnect multipoint connector (bottom)
- Loosen 3 screws from top.
- Carefully lift out tape tension sensor through the top.

3.1.8**Linke Bandumlenkrolle ausbauen**

- Permanentmagnet ausbauen, 2 Schrauben von unten lösen
- Kontermutter an der Schwungmassenachse lösen
- Schwungmasse mit Scheibe ausfahren
- Bandumlenkrolle ausbauen (1 Schraube lösen)
- Lagerflansch ausbauen (3 Schrauben lösen).

3.1.9**Rechte Bandumlenkrolle (Bandbewegungssensor) ausbauen**

- Deckel senkrecht nach oben abziehen
- Bandumlenkrolle ausbauen, 1 Schraube lösen
- Mehrfachstecker von unten lösen
- 3 Schrauben von oben lösen
- Bandumlenkrolle vorsichtig nach oben ausfahren.

3.1.10**Drucktastenaggregat und Zähler ausbauen**

Drucktastenaggregat:

- 1 Mehrfachstecker lösen
- 2 Schrauben von oben lösen
- Drucktastenaggregat vorsichtig nach oben ausfahren

Zähler (elektronisch mit Zero-Loc):

- 3 Mehrfachstecker lösen
- 2 Schrauben von oben lösen
- Zähler vorsichtig nach oben ausfahren.

3.1.11**Netz- und Geschwindigkeitsschalter ausbauen**

- 2 Mehrfachsteckverbindungen lösen
- 3 Schrauben von oben lösen
- Schalter vorsichtig nach vorne ausfahren.

3.1.12**EDIT-Regler (für variables Umspulen) ausbauen**

- 1 Mehrfachstecker lösen
- 2 Schrauben von oben lösen
- Regler vorsichtig nach vorne ausfahren.

3.1.8**Dismantling of left-hand guide roller**

- Dismantle permanent magnet, loosen 2 screws from below.
- Loosen bottom lock nut of flywheel axle.
- Slide out flywheel mass together with disk
- Dismantle guide roller (1 screw).
- Dismantle bearing flange (3 screws).

3.1.9**Dismantling of right-hand guide roller (tape motion sensor).**

- Remove cover by pulling vertically
- Dismantle guide roller (1 screw)
- Disconnect multipoint connector from below
- Loosen 3 screws from top
- Carefully slide out guide roller through the top

3.1.10**Dismantling of push button unit and counter**

Push button unit:

- Unplug 1 multipoint connector
- Loosen 2 screws from top
- Carefully lift out push button unit

Counter (electronical with zero locator)

- Unplug 3 multipoint connectors
- Loosen 2 screws from top
- Carefully lift out counter

3.1.11**Dismantling of AC power switch and speed selector**

- Unplug 2 multipoint connectors
- Loosen 3 screws from top
- Carefully slide out switch towards front

3.1.12**Dismantling of EDIT control assembly (variable wind).**

- Unplug 1 multipoint connector
- Loosen 2 screws from top
- Carefully slide out EDIT control assembly towards front

3.1.13**Netzeinheit ausbauen**

- Je nach Gerätetyp, 3 oder 4 Mehrfachstecker von der Geräterückwand lösen
- Steckkarte POWER CONNECTOR (EL 1, links von der Netzeinheit im Steckkartenmagazin CONTROL UNIT) lösen
- Netzeinheit von unten halten
- 4 Schrauben von oben lösen.

3.2**ALLGEMEINE ABKÜRZUNGEN**

Für alle Bezeichnungen und Abkürzungen sind die englischen Ausdrücke verbindlich.

3.2.1**Signalabkürzungen**

Y	Signal	(Funktion) allgem.
BI	Binär	(dauernd)
PS	Impuls	(kurzzeitig)
AC	Wechsel	
DC	Gleich	
AN	Analog	

3.2.2**Signalnamen**

ACCEL	ACCELERATE	Beschleunigung (Start)
BIAS		Vormagnetisierung
BRAKE		Bremsen (elektrisch)
CUT	CUTTER, CUE	Edit (Schneiden, Montage)
CLK	CLOCK	Takt
CUTAU	CUTAUT	Edit (automatisch)
DIR	DIRECTION	Richtung (Band)
END		Ende
ERAS	ERASE	Löschen
FAD	FADER	Regler (Kontakt)
FORW	FORWARD	Vorwärts (schnell)
GND	GROUND	Masse
HI	HIGH	schnelle Bandgeschwindigkeit
INDIC	INDICATOR	Anzeige (Lampen)
LIFT		Bremsen lüften (mechanisch)
LO	LOW	langsame Bandgeschwindigkeit
MOVE		Bewegung
PRESS	PRESSURE	Andruck
REC	RECORD	Aufnahme
REM	REMOTE	Fernsteuerung
REPR	REPRODUCE	Wiedergabe
RESET		Rückstellung (Zähler)
REW	REWIND	Rückwärts (schnell)
STOP		Stop

3.1.13**Dismantling of power supply**

- Depending on model, unplug 3 or 4 multi-point connectors from rear panel.
- Remove POWER CONNECTOR board (EL 1, to the left of power supply in card rack CONTROL UNIT)
- Support power supply from bottom
- Loosen 4 screws from top

3.2**EXPLANATION OF ABBREVIATIONS**

For all labels and abbreviations, the English version constitutes the binding designation.

3.2.1**Signal abbreviations**

Y	Signal	(function) general
BI	Binary	(continuous)
PS	Impulse	(short duration)
AC	Alternating current	
DC	Direct current	
AN	Analog	

3.2.2**Signal labels**

ACCEL	ACCELERATE	
BIAS	BIAS	
BRAKE		
CUT	CUTTER, CUE	
CLK	CLOCK	
CUTAU	CUTAUT	(automatic edit)
DIR	DIRECTION	(tape)
END		
ERAS	ERASE	(contact)
FORW	FORWARD	(fast)
GND	GROUND	
HI	HIGH	(tape speed)
INDIC	INDICATOR	(lamp)
LIFT	LIFT	(brake, mechanical)
LO	LOW	(tape speed)
MOVE		
PRESS	PRESSURE	(roller)
REC	RECORD	
REM	REMOTE	(remote-control)
REPR	REPRODUCE	(play-back)
RESET		
REW	REWIND	
STOP		

Beispiel für eine Signal-Bezeichnung:

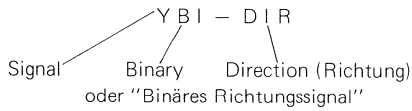

Example of a signal code:

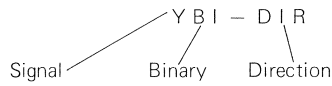

3.2.3 Referenzbezeichnungen

B	BULB	Lämpchen
F	FUSE	Sicherung
FF	FLIP-FLOP	Kippschaltung
G	GATE	Gatter (IC)

Da eine integrierte Schaltung mehrere Gatter aufweist, sind die einzelnen Gatter durch die Nummer des IC und den Anschluss des Gatter-Ausgangs gekennzeichnet, z.B. 12-8

3.2.3 Reference labels

B	BULB	
F	FUSE	
FF	FLIP-FLOP	
G	GATE (IC)	

Because an IC comprises several gates, these are individually identified by the IC number and the gate output connection, e.g. 12-8.

K		Elektromagnet, Relais, Schütz (Coil)
KEY	(CODING)	Kodierungseinsatz für Steckkartensockel
M	MOTOR	Motor
QP	PHOTO TRANSISTOR	Foto-Transistor
QPWR	POWER TRANSISTOR	Leistungs-Transistor
RP	PHOTO RESISTOR	Foto-Widerstand
S	SWITCH	Schalter, Micro-Schalter
TT	TAPE TENSION	Bandzug

K		Electromagnet, relay, contactor (coil)
KEY	CODING	Key for circuit board socket
M	MOTOR	
QP	PHOTOTRANSISTOR	
QPWR	POWER TRANSISTOR	
RP	PHOTO RESISTOR	
S	SWITCH	
TT	TAPE TENSION	

3.2.4 Transistoranschlüsse

Q-1	EMITTER	Emitter
Q-2	BASE	Basis
Q-3	COLLECTOR	Kollektor

3.2.4 Transistor connections

Q-1	EMITTER
Q-2	BASE
Q-3	COLLECTOR

3.2.5 Drahtfarben

0	blk	schwarz
1	brn	braun
2	red	rot
3	org	orange
4	yel	gelb
5	grn	grün
6	blu	blau
7	vio	violett
8	gry	grau
9	wht	weiss
-	unc	farblos

3.2.5 Wiring colors

0	blk	black
1	brn	brown
2	red	
3	org	orange
4	yel	yellow
5	grn	green
6	blu	blue
7	vio	violet
8	gry	grey
9	wht	white
-	unc	uncolored transparent

3.2.6 Micro-Switches-Anschlüsse

1	COMMON	gemeinsamer Anschluss
2	CLOSED	Ruhekontakt
3	OPEN	Arbeitskontakt

3.2.6 Microswitch connections

1	COMMON
2	CLOSED
3	OPEN

3.3 FUNKTIONSBESCHREIB DER LAUFWERK- STEUERUNG

3.3.1 Anordnung der Steuerelektronik

Die gesamte Laufwerksteuerung ist im Interesse einer optimalen Service-Zugänglichkeit auf Steckkarten identischer Grösse in einer Steuereinheit (Rack) konzentriert. Das Rack enthält folgende Steckkarten:

3.3 FUNCTIONAL DESCRIPTION OF TAPE DRIVE CONTROL

3.3.1 Layout of electronic controls

For optimum service accessibility, all electronic controls are mounted on cards of identical size which are mounted in a control unit (rack). The rack comprises the following cards:

Bezeichnung	Description	Schaltbild Nr. Diagram No	CONTROL UNIT	
			GR 20	EL...
ZERO LOCATOR	ZERO LOCATOR	1.080.395		11
Eingangs-Abschwächer ATTENUATOR	Input ATTENUATOR	1.080.396		10
IC-Speicher IC-MEMORY AND COUNTER	IC MEMORY and COUNTER	1.080.393		9
IC-Decoder und Treiber IC DECODER AND DRIVERS	IC DECODER and DRIVERS	1.080.391		8
Tonmotor-Regelung CAPSTAN SERVO	CAPSTAN SERVO	1.080.374/372/377 1.080.376		6
Wickelmotor-Steuerung SPOOLING MOTOR CONTROL	SPOOLING MOTOR CONTROL	1.080.383 1.080.385		5
Wickelmotor-Schützen CONTACTORS	Spooling MOTOR CONTACTORS	1.080.380 1.080.381		4
Spannungs-Stabilisator STABILIZER	Voltage STABILIZER	1.080.370		2

Eine Reihe von Sensor-Elementen überwacht kontinuierlich folgende Eigenschaften:

Vorhandensein des Bandes:
Fotoendschalter (YBI-END)

Band-Bewegung:
TAPE MOVE SENSOR (YBI-MOVE)

Band-Bewegungsrichtung:
TAPE DIRECTION SENSOR (YBI-DIR)

Bandzug:
TAPE TENSION SENSORS (R-TT1, R-TT2)

Tonmotor-Drehzahl:
TACHO HEADS (YAC-M3)

The following states are permanently monitored by a number of sensors:

Presence of tape:
Optical tape-end sensor (YBI-END)

Tape motion:
TAPE MOVE SENSOR (YBI-MOVE)

Tape direction:
TAPE DIRECTION SENSOR (YBI-DIR)

Tape tension:
TAPE TENSION SENSORS (R-TT1, R-TT2)

Capstan speed:
TACHO HEADS (YAC-M3)

Diese Sensoren liefern der Steuerlogik der Wickelmotor-Steuerung und der Tonmotor-Steuerung völlig automatisch die für die Steuerung notwendigen Daten. Dadurch wird ein optimaler Funktionsablauf und eine konstante Präzision im Bandtransport gewährleistet.

3.3.2

Drucktasten

Die Laufwerk-Ansteuerung erfolgt über großflächige, beleuchtete Impuls-Drucktasten (LOCAL CONTROL SWITCHES) oder über einen identischen Fernsteuersatz (REMOTE CONTROL SWITCHES). Die Tastenbeleuchtung des lokalen Tastensatzes wie auch des Fernsteuersatzes erfolgt als Rückmeldung des durchgeschalteten Steuerbefehls.

3.3.3

Reglerstart

In gleicher Weise steht auch ein Rückmeldesignal (FADER INDICATOR) für den Reglerstart zur Verfügung.

3.3.4

Verriegelung

Die Tastensteuerung ist gegen Fehlbedienung verriegelt, eingetastete Befehle werden elektronisch gespeichert. Deshalb kann von der schnellen Umspulfunktion direkt die Wiedergabetaste PLAY gedrückt werden. Während dem Stoppvorgang leuchten die Tasten PLAY und STOP; sobald das Band stillsteht erlischt die Taste STOP und die Wiedergabefunktion wird aus dem Speicher in die Steuerung freigegeben.

3.3.5

EDIT-Taste

Die EDIT-Taste ist nur bei stillstehendem Band oder während dem schnellen Umspulen wirksam (siehe auch 3.3.6). In letzterem Falle ist die Funktion jedoch nur bei gedrückter Taste aktiv.

A EDIT-Position mit eingefahrenen Andruckrollen:

In EDIT-Position (EDIT-Regler auf Mittelstellung) sind die Andruckrollen soweit eingefahren, dass das Band auf dem Wiedergabekopf aufliegt, von der Tonwelle jedoch nicht transportiert wird. Die Gummi-Andruckrolle liegt nicht auf der Tonwelle auf. Bei stillstehendem Band werden die Bandwaagen elektromagnetisch blockiert, so dass nach dem Auffinden der Schnittstelle keine Pendelbewegungen des Bandes auftreten können.

These sensors automatically supply the necessary data to the control logic of the spooling motor control and the capstan servo. In this manner, optimum function control and constant accuracy in the tape transport are assured.

3.3.2

Control switches

The tape functions are selected via large, illuminated impulse-type plunger keys (LOCAL CONTROL SWITCHES) or via an identical set of REMOTE CONTROL SWITCHES. The appropriate local and remote key is illuminated to provide visual verification of the control function in progress.

3.3.3

Fader start

Similar to the above, a feedback signal (FADER INDICATOR) is available for the fader start operation.

3.3.4

Interlocks

The control keys are interlocked against erroneous manipulation. The commands issued through key depression are stored electronically. For this reason it is possible to select the playback function (PLAY) while fast rewind is still in progress. During the stop function, both PLAY and STOP will light up. As soon as the tape is stopped the STOP key illumination is extinguished and the playback function is released from memory.

3.3.5

EDIT key

The EDIT key is only effective while the tape is stationary or during fast rewind (also see 3.3.6). During fast rewind the EDIT function is active only as long as the EDIT key remains depressed.

EDIT position A with pinch rollers in:

With the EDIT control knob in center position, the pinch rollers are dropped in to a point where the tape rests on the reproducing head without causing the tape to be transported by the capstan. The rubber pinch roller does not touch the capstan. As long as the tape remains stationary, the tape tension sensors remain blocked to eliminate tape sway.

B EDIT-Position mit Bandanlege-Schieber:

Nach Betätigen der EDIT-Taste werden die Bandwaagen blockiert und die EDIT-Regler Funktion freigegeben. Die Andruckrollen fahren in EDIT-Position. Sobald der EDIT-Reglerknopf gedreht wird, fahren die Andruckrollen in ihre Ausgangsposition zurück. Um das Band an den Wiedergabekopf heranzuführen, ist zwischen der Andruckrolle und der rechten Umlenkrolle ein Schieber angebracht.

3.3.6

Zwischenhören

Wird die EDIT-Taste während dem schnellen Umspulen betätigt, so fahren die Andruckrollen auf EDIT-Position, wodurch die Bandaufzeichnung hörbar wird. Die Bandwaagen werden dabei nicht blockiert.

3.3.7

Automatischer EDIT-Betrieb

In EDIT-Position (Taste EDIT gedrückt) können die Wickelmotoren mit dem EDIT-Regler stufenlos in beiden Richtungen gesteuert werden.

EDIT-Regler in die gewünschte Laufrichtung drehen. Die Bandgeschwindigkeit wird durch den gewählten Drehwinkel des Reglers bestimmt.

Der Regler besitzt in seiner Mittelstellung eine Rasterung. Die Deblockierung der Bandzugwaagen erfolgt durch das Drehen des Reglers aus seiner Rasterstellung.

3.4

STEUERLOGIK

Die Steuer-Logik ist auf die Steckkarten:

Eingangsschwächer 1.080.396.00
ATTENUATOR AND PREAMP

IC-Speicher 1.080.393.00
IC MEMORY AND COUNTER

IC-Decoder und Treiber 1.080.391.00
IC-DECODER AND DRIVERS
aufgeteilt und dadurch örtlich getrennt.

3.4.1

Eingangsschwächer ATTENUATOR AND PREAMP

siehe Schaltbild 1.080.396 GR 20 EL 10

Steuersignale, die vom lokalen Drucktastensatz, vom Fernsteuer-Tastensatz, vom Reglerstart-Relais und vom Geschwindigkeitsschalter eintreffen, werden im Eingangsschwächer abgeschwächt. Die Befehlsgebung erfolgt dadurch, dass der entsprechende Eingang von den Tastenk-

EDIT position B with tape pressure slide:

After depressing the EDIT key, the tape tension sensors are blocked and the EDIT function activated. The pinch rollers move into EDIT position. As soon as the EDIT control knob is rotated, the pinch rollers return to their neutral position. A slider attached between pinch roller and tape guide presses the tape against the reproducing head.

3.3.6

Cueing

When the EDIT key is depressed during fast rewind, the pinch rollers return to the EDIT position rendering the recording audible. The tape tension sensors are not blocked.

3.3.7

Automatic EDIT operations

While the EDIT key is depressed, the spooling motors can be infinitely controlled in either direction by turning the EDIT control knob.

Turn EDIT control knob in desired tape direction. The tape speed is determined by the distance the knob has travelled from its center position.

The control knob has a detent in its neutral position. The tape tension sensors are deblocked when the knob leaves its center position.

3.4

CONTROL LOGIC

The control logic is allocated to individual plug-in boards and therefore also physically separated:

ATTENUATOR AND PREAMP 1.080.396.00

IC MEMORY AND COUNTER 1.080.393.00

IC DECODER AND DRIVERS 1.080.391.00

3.4.1

ATTENUATOR AND PREAMP

see circuit diagram 1.080.396 GR 20 EL 10

The control signals originating from the local set of command keys and the remote control keys, from the fader start relay and the speed selector are reduced by the attenuator. Commands are issued by placing "L" potential at the corresponding input from the key contacts. The output of

takten auf Potential Null gelegt wird. Am Ausgang des Abschwächers entsteht bei Betätigen einer Drucktaste eine logische Null.

Die entsprechenden Signalspannungen betragen für:

logisch "L" = max. + 0,4 V

logisch "H" = min. + 2,4 V
(normal belastete IC-Ausgänge)
ca. 0,7 V

(IC-Ausgang belastet mit Treiber Transistor)

the attenuator supplies a logical "LOW" when a key is depressed.

The corresponding signal voltages are as follows:

Logical "L" max. +0.4V

Logical "H" min. + 2.4 V
(normally loaded IC outputs)
approx. 0.7 V

(IC output loaded by driver transistor)

Die Priorität der Tastenfunktion ist durch die Reihenfolge der Tastenkontakte gegeben. Oberste Priorität besitzt der Relaiskontakt des Reglerstart-Relais, daraus folgt der Kontakt STOP usw. Die Ansteuerung des Reglerstart-Relais erfolgt über eine Graetz-Brückenschaltung mittels interner Speisung, wobei die Polarität der Steuerspannung nicht berücksichtigt werden muss. Die Reglerstart-Funktion kann auch zum "Aussteigen" von allen Kanälen aus dem Aufnahme- in den Wiedergabemodus verwendet werden.

Die Steckkarte "Eingangs-Abschwächer" enthält auch die Vorverstärker für den Bandendschalter und den Bandbewegungs-Sensor sowie einen Sicherheitskreis, der die Logik auf STOP-Funktion schaltet, solange die Speise-Spannung ihren Soll-Wert nicht erreicht.

Bandendschalter

Bei eingelegtem Band ist der Fotowiderstand RP-END dunkel, das resultierende Signal YBI-END ist "H".

Die Speisespannung für den Fotowiderstand (+ 16 V) wird über den Längstransistor (Q1) von der + 24 V Speisespannung geliefert.

Die Empfindlichkeit der Lichtschranke kann mit dem Potentiometer R47 eingestellt werden.

Sicherheitskreis SAFETY CIRCUIT

Die Funktion des Fotoelement-Verstärkers Q3, Q2 wird vom Schaltzustand von Q4 beeinflusst. Im Sicherheitskreis werden die Speisespannungen + 24 V und + 5,8 V überwacht. Solange nicht beide Spannungen ihren Sollwert erreicht haben, ist einer der Transistoren Q6 oder Q7 gesperrt und Transistor Q4 wird leitend. Das Bandendschalter-Signal YBI-END wird "L", was gleichbedeutend ist wie die Funktion STOP.

Gleichzeitig wird der Transistor Q8 gesperrt, ein allfälliges Aufnahmesignal (YBI-REC = "H") wird blockiert und die Aufnahmerelais in den Verstärkerkanälen fallen ab, bzw. können nicht anziehen.

The priority of the functions is determined by the sequence of the key contacts. Top priority is given to the contact of the fader-start relay, followed by the STOP contact, etc. The fader-start relay is selected by a Graetz full-wave rectifier with internal supply. The polarity of the control voltage is not relevant. The fader start function can also be used to "drop out" from record into playback mode for all channels.

The "Attenuator" board also contains the pre-amplifier for the tape end switch and the tape motion sensor as well as a safety circuit which forces the circuit into a STOP function as long as the supply voltage has not reached its nominal value.

Tape-end switch

When a tape is mounted, the photoresistor RP-END is dark and the resulting signal YBI-END is at logical "H".

The supply voltage for the photoresistor (+ 16V) is supplied from the + 24 V supply voltage via longitudinal transistor (Q1).

The sensitivity of the light barrier can be adjusted with potentiometer R47.

SAFETY CIRCUIT

The function of the photoelement amplifier Q3, Q2 depends on the switched state of Q4. In the safety circuit, the supply voltages + 24 V and + 5.8 V are continuously monitored. Transistor Q6 or Q7 remains blocked as long as both nominal voltages have not been reached and transistor Q4 becomes conductive. The tape-end signal YBI-END becomes logical "L" which is equivalent to the STOP function.

At the same time, transistor Q8 is blocked. The potential presence of a RECORD signal (YBI-REC = "H") is masked and the record relays in the amplifier channels drop out, resp. cannot pick up.

Bandbewegungssensor Verstärker

Da die Logik bei Lauffunktions-Übergängen selbstständig die gespeicherten Befehle weitergibt, muss sie über den Bewegungszustand des Bandes informiert sein. Zu diesem Zweck sind an der rechten Bandumlenkrolle Sensoren angebracht, welche die dazu nötigen Signale erzeugen. Nach entsprechender Umwandlung geben diese Signale Auskunft über Bandbewegung, Bandbewegungsrichtung und die durchlaufende Zeit (Bandzähler).

Die Impulse, die vom Foto-Transistor QP-MOVE (QP2, TAPE MOVE SENSOR, 1.080.185/186) bei laufendem Band geliefert werden, werden gleichgerichtet, integriert und verstärkt und ergeben für das Signal Q-MOVE eine logische "H".

Auf der Steckkarte 1.080.396-13 (Standardkarte für MK II Geräte) befindet sich eine zusätzliche Stufe (Q9), welche das Signal YPS-MOVE über den Fernsteuerstecker (GR 22) für die A80-Vorwahleinheit liefert (für Geschwindigkeitsauswertung).

3.4.2

IC-MEMORY AND COUNTER

siehe Schaltbild 1.080.393 GR 20 EL 9

Die integrierten Schaltungen sind numeriert, ebenso sind in den Schaltbildern die Anschlüsse angegeben. Ein bestimmtes "Gate" wird in den folgenden Erklärungen durch die IC-Nummer und den Anschluss des Ausgangs bezeichnet, z.B. Gate 12-8.

Die Steckkarte "IC-Speicher" enthält den integrierten Speicher, den Bandrichtungs-Detektor und die Elektronik für den Bandzähler mit Takterzeugung, Zählrichtungsumschalter und Schrittmotor-Signal-Regeneration.

IC-Speicher

Der IC-Speicher hat die Aufgabe, die logischen Steuersignale vom Eingangs-Abschwächer zu speichern und im Funktionsablauf gleichzeitig das Endschaltsignal YBI-END und das Bewegungssignal YBI-MOVE zu berücksichtigen.

Die Eingangssignale sind im Ruhezustand mit eingelegtem Band alle "H", mit Ausnahme des Einganges YBI-FAD, dessen Ruhe-Signal = "L" ist.

Für die Steuersignalspeicherung sind 4 Flip-Flops FF1 bis 4 vorgesehen. Ein weiteres Flip-Flop (FF0) ist mit Gate 12-8 als History-Element geschaltet und berücksichtigt, neben dem Bandbewegungssignal, auch den Zustand, der vor dem Übergang einer Funktion herrschte.

Tape-motion sensor amplifier

Because the logic automatically transmits previously stored commands when changing functions, it must also be informed about the status of the tape motion. For this purpose, the right-hand tape guide is fitted with tape-motion sensors, which generate the necessary control signals. After converting the signal to the desired form it becomes possible to determine running direction and elapsed transportation time (counter).

The impulses generated by phototransistor QP-MOVE (QP2, TAPE MOVE SENSOR, 1080.185/186) while the tape is in motion, are rectified, integrated and amplified, and result in a logical "H" for the signal Q-MOVE.

Circuit board 1.080.396-13 (standard board for MK II units) contains an additional stage (Q9), which supplies the signal YPS-MOVE via remote-control plug (GR 22) for the A80 preselector unit (for tape speed evaluation).

3.4.2

IC-MEMORY AND COUNTER

(See circuit diagram 1.080.393 GR 20 EL 9)

The integrated circuits are numbered and the connecting points are indicated in these diagrams. In the following specifications, a specific "gate" is identified by the IC number and the output connector, e.g. gate 12-8.

Circuit board "IC-MEMORY" contains an integrated memory, the tape direction sensor and the electronics for the tape counter together with its clock pulse generator, counting direction reversal and step-motor signal regeneration.

IC memory

The IC memory stores the logical control signals coming from the attenuator and also evaluates the tape end sensor signals YBI-MOVE.

In quiescent state, the input signals remain at logical "H" except for the input YBI-FAD, whose quiescent state is "L".

To store the command signals, 4 flip-flops labelled FF1 to FF4 are available. An additional flip-flop (FF0) serves as history element together with gate 12-8 which not only considers the tape motion signal but also the state prevailing prior to a change in tape function.

Bandrichtungsdetektor

Beim Bremsvorgang werden die Wickelmotoren mit Gleichstrom gebremst. Damit auch in dieser Bewegungsphase der zulässige Bandzug nicht überschritten wird, wird der Bremsstrom für den jeweils aufwickelnden Motor geregelt. Die Steuer-Elektronik muss daher informiert werden, in welcher Richtung sich das Band bewegt (Vor- oder Rückspulen, angesteuert durch die Bedienungstasten oder den Regler EDIT).

Diese Richtungsinformation wird zusätzlich auch für den Bandzähler benötigt und wird deshalb direkt vom Band über die rechte Bandumlenkrolle bezogen. Der Bandrichtungs-Sensor liefert zwei um 90° phasenverschobene Rechtecksignale (QP-DIR 1 und QP-DIR 2). An den Gates 8-8 und 6-6 werden zwei um 180° phasenverschobene Rechteckspannungen abgezweigt, die für die Erzeugung des Takt-Impulses zur Zählersteuerung verwendet werden.

Eine Detektorschaltung erzeugt das Richtungssignal YBI-DIR, welches einerseits für die Steuerung der Bremsstromverteilung benötigt wird und andererseits den Zählrichtungsumschalter für den Bandzähler ansteuert.

Takterzeugung für den Bandzähler

Die abgezweigten, um 180° phasenverschobenen Rechteckspannungen P2 und $\bar{P}2$ werden durch die Kapazitäten C16 und C21 differenziert. Die positiven Flanken ergeben schmale Impulse, die bei der tiefen Bandgeschwindigkeit im Gate 2-6 zusammengesetzt werden. Bei der hohen Bandgeschwindigkeit ist einer der Ausgänge von Gate 4-8 oder 4-11 dauernd "L", so dass die entsprechenden Pulse nicht wirksam werden. Damit ist die Frequenzteilung entsprechend der Bandgeschwindigkeit gegeben, der Zähler zeigt immer Echtzeit an. Diese Pulse werden in C18 nochmals differenziert, wobei die hintere, positive Flanke den Takt-Impuls erzeugt. Im Gate 4-1 wird der Takt-Impuls gesperrt sobald YBI-END "L" wird, d.h. wenn das Bandende den Fotoendschalter passiert.

Der Takt-Impuls steuert die Schritt-Motor-Signal-Regeneration der D-Flip-Flops 7.

Zählrichtungsumschalter Schrittmotorsignal Regeneration

Das Richtungs-Signal YBI-DIR bestimmt zusammen mit den Rückkopplungs-Signalen der Schrittmotor-Signal-Regeneration die Ausgangssignale der NOR-Gates 5-8 und 5-6, welche auf die Setz-Eingänge der D-Flip-Flops wirken. Die Takt-Impulse (CLOCK) schalten diese Signalzustände durch und bestimmen damit den Schritt-Rhythmus des Bandzähler-Antriebsmotors.

Der elektronische Zähler wird aus Kompatibilitätsgründen durch dieselbe Schnittstelle angesteuert.

Tape direction sensor

Braking of the spooling motors occurs with DC power. To prevent excessive tape tension during the braking phase, the braking current for the active spooling motor is regulated. For this reason, the controlling electronics must be informed about the direction of the tape motion (forward, rewind, as selected the operating keys or the EDIT control knob).

The directional data is also used by the tape counter and generated directly at the right-hand tape guide. The tape direction sensor supplies two square-wave signals, phase-shifted by 90° (QP-DIR 1 and QP-DIR 2). Two square-wave voltages, phase-shifted by 180° are diverted at gates 8-8 and 6-6 and are used for generating the clock pulses for indexing the counter.

A detector circuit generates the direction signal YBI-DIR which is used to regulate the braking current allocation and also sets the counting direction switch for the tape counter.

Clock generation for tape counter

The diverted square-wave voltages, P2 and $\bar{P}2$ phase-shifted by 180° , are differentiated by capacitances C16 and C21. The positive slope produces narrow impulses which are assembled in gate 2-6 for the lower tape speed. At high tape speed, one of the outputs at gate 4-8 or 4-11 is permanently at "L" inhibiting activation of the corresponding impulses. In this manner, frequency division corresponding to the tape speed is effected and the timer always indicates true elapsed time. These impulses are again differentiated in C18 where the trailing, positive slope is used to generate the clock pulse. The clock impulse is blocked in gate 4-1 as soon as YBI-END becomes "L", i.e. when the tape end passes the optical tape-end sensor.

The clock pulse controls the step-motor signal regeneration of the D-flip-flops 7.

Counting direction reversal Step-motor regeneration

The direction signal YBI-DIR together with the feedback signals of the step-motor signal regeneration determines the output signals of the NOR gates 5-8 and 5-6 which affect the setting inputs of the D-flip-flops. The clock impulses (CLOCK) transfer these signal states and thereby determine the step rhythm of the tape counter and drive motor.

For compatibility reasons, the electronic counter is selected by the same interface.

3.4.3**IC-DECODER AND DRIVERS**

siehe Schaltbild 1.080.391 GR 20 EL 8

Die Steckkarte "IC-Decoder und Treiber" enthält die Kontrollstufen für die Funktion der Sensor-Leuchtdioden bzw. Lampen bei MK I Geräten, den Bewegungs-Simulator und den IC-Decoder mit vorgeschalteter Freigabe-Stufe (ENABLE GATES), der die kodierten Funktions-Signale entschlüsselt und die Treiberstufen ansteuert.

Kontrrollstufen für Sensorleuchtdioden (Lampen)

Die Sensor-Leuchtdioden werden über die Serien-Widerstände R1 und R2 (Bandrichtungs-Sensor), bzw. R9 und R10 (Bandbewegungs-Sensor) gespeist. Die Verstärkerstufen (Q1, Q2 bzw. Q3) liefern die dem Funktionszustand entsprechenden digitalen Signale an die Logik. Bei defekten Leuchtdioden sind diese für Ausgang Q2 = "L", bzw. für Q3 = "H".

Beide Signale bewirken, dass TEST-B "L" wird, was weiter zur Folge hat, dass über die Blink-Automatik (Steckkarte Wickelmotor-Schützen, 1.080.381) die betätigten Drucktasten blinken.

Gleichzeitig wird das Signal K-BRAKE blockiert (bleibt = "H") d.h. der Brems-Schütz schaltet nicht mehr auf elektronisch gesteuerte Bremsung, wenn mangels fehlender Richtungs-Information die elektronische Bremsstrom-Verteilung nicht mehr arbeitet, oder das Bewegungs-Signal nicht mehr über den Zustand "Bandstillstand" informieren wird.

Die Brämsung erfolgt nur noch mechanisch. Mit dieser Einschränkung ist der Betrieb aber weiterhin in sämtlichen Funktionen möglich, wenn Leuchtdioden des Richtungssensors (K-DIRECTION) defekt sind. Dasselbe gilt jedoch nicht, wenn die Bewegungs-Sensor-Leuchtdiode ausfällt. Daher ist für diesen Fall eine spezielle Simulation vorgesehen.

Bandbewegungs-Simulation

Weil bei defekten Bandbewegungs-Sensor-Leuchtdioden die Logik nicht mehr erkennen kann, wann das Band stillsteht, wird ein dauerndes Bewegungs-Signal simuliert. (Gate-Eingang 9-1 ist "L", Ausgang 9-3 wird "H".) Somit ist YBI-MOVE konstant "H", was zur Folge hat, dass YBI-FF0 für die Steuerbefehle "Wiedergabe" und "Aufnahme" nicht mehr "H" werden kann (FF2 und FF3 = "H") und somit die Durchschaltung dieser Befehle blockiert ist.

3.4.3**IC-DECODER AND DRIVERS**

(see circuit diagram 1.080.291 GR 20 EL 8)

Circuit board "IC Decoder and Drivers" contains the stages for controlling the function of the sensor LEDs (or lamps for MK I), the motion simulator and the IC Decoder with an enabling stage serially connected to its input (ENABLE GATES). It decodes the function signals and selects the driver stages.

Control stages for sensor LEDs (lamps)

The sensor LEDs are supplied by the series resistors R1 and R2 (tape direction sensor) or R9 and R10 (tape motion sensor). The amplifier stages (Q1, Q2 or Q3) supply the logic with digital signals corresponding to the functional status. If the LEDs are defective, the outputs are as follows: Q2 = "L" and Q3 = "H".

Both signals cause TEST-B to assume "L" causing the depressed command key to flash (circuit board "spooling-motor contactor 1.080.381").

At the same time, signal K-BRAKE is blocked (remains "H", i.e. the brake contactor no longer switches to electronic controlled braking if the electronic brake current allocation is inoperative due to missing directional data or if the motion signal no longer supplies data on the "stationary" state of the tape.

Braking is limited to mechanical action. Except for this constraint, all other functions remain operative with defective LEDs in the direction sensor (K-DIRECTION). However, this does not apply when the motion sensor LED becomes defective. To cope with this situation, a special simulation is available.

Tape motion simulation

Because the logic can no longer recognize when the tape has come to a standstill in case the tape motion sensor LEDs are defective, a motion signal is continuously simulated (gate input 9-1 is at "L", output 9-3 becomes "H"). In this manner, YBI-MOVE constantly remains at "H", thereby preventing YBI-FF0 from becoming "H" with commands PLAYBACK and RECORD (FF2 and FF3 = "H" and the transfer of these commands is effectively blocked).

Damit sind die Funktionen, die über STOP ablaufen blockiert. Tritt der Ausfall einer Bewegungs-Sensor-Leuchtdiode während einer bestehenden Funktion ein, so bewirkt das simulierte Bewegungs-Signal, dass diese Funktion aufrechterhalten bleibt, bis die Taste STOP gedrückt wird oder das Bandende erreicht ist.

Die Funktionen für schnelles Umspulen können aber weiterhin aktiviert werden.

IC-Decoder und Treiber

Der IC-Decoder entschlüsselt die kodierten Funktions-Signale FF1 bis FF4 und stellt die logischen Verknüpfungen für das Zusammenwirken der elektromechanischen Elemente wie Wickelmotoren, Elektromagnete, Schützen und der Anzeige-Lämpchen her.

Der eigentlichen Decodierung ist eine Freigabestufe vorgelagert, welche die Aufgabe hat, bei YBI-FF0 = "L" (Funktionsübergänge, die Bandstillstand erfordern) die Weiterschaltung der gespeicherten Befehle zu blockieren bis YBI-MOVE "L" wird.

(Eine Ausnahme bildet die Cutter-Position, welche ebenfalls nur bei Bandstillstand erfolgen kann.)

Die meisten Decoder-Ausgänge enthalten eine Treiber-Stufe (Q4 bis Q15). Ein Signal "H" an der Basis eines Treiber-Transistors ergibt eine logische "L" für den Ausgang, d.h. der Transistor ist durchgeschaltet, es fließt Steuerstrom für Magnete, Anzeigelämpchen, usw. (damit fällt das Kollektor-Potential von + 24 V praktisch auf Masse-Potential ab).

Es ist zu beachten, dass die Testpunkte im IC-Decoder nicht an den Ausgängen liegen, sondern wahlweise an den Basen der Treiber-Transistoren oder vor dem letzten Inverter ausgekoppelt werden.

Aus dem Gesagten geht hervor, dass ein elektromechanisches Element aktiviert ist, wenn eine logische "L" am Ausgang gemessen wird (Treiber-Transistor durchgeschaltet).

Die Treiber-Ausgänge mit den Signalen K-CUT und K-TT sind durch eine Diode verbunden.

3.4.4

Wickelmotorsteuerung

SPOOLING MOTOR CONTROL

siehe Schaltbild 1.080.383/385 GR 20 EL 5

Für den Wickelantrieb sind robuste Wechselstrommotoren mit grossem Drehmoment eingesetzt. Beide Motoren werden elektronisch geregelt. Die Verarbeitung der Steuer- und Regelsignale erfolgt völlig kontaktlos.

In this manner, all functions executed after STOP are blocked. If a tape motion sensor LED fails while a function is in progress, the simulated tape motion signal causes this function to continue until the STOP key is depressed or the tape end is sensed.

The fast wind functions can still be activated.

IC Decoder and driver

The IC Decoder decodes the coded function signals FF1 to FF4 and supplies the logical links for the interaction of the electromechanical elements such as spooling motors, electromagnetic contactors and display lamps.

An enabling state is serially connected to the input of the decoder. Its function is to block the transfer of stored signals in case of YBI-FF0 = "L" (function changes requiring tape stop), until YBI-MOVE changes to "L".

(The cutter positioning is an exception. It also can only be performed with a stationary tape).

Most decoder outputs are equipped with a driver stage (Q4 to Q15). An "H" signal at the base of the driver transistor results in a logical "L" at the output, i.e. the transistor is switched through and current flows to the magnets, display lamps, etc. (causing the collector potential to drop from + 24 V to practically ground potential).

It should be noted, however, that the test points for the IC decoder are not located at the outputs but are located either at the driver transistor or decoupled prior to the last inverter.

The above description makes clear that an electromechanical device is activated when a logical "L" is detected at the output (driver transistor switched through).

The driver outputs with the signals K-CUT and K-TT are interconnected by a diode.

3.4.4

SPOOLING MOTOR CONTROL

(see circuit diagram 1.080.383/385 GR 20 EL 5)

Heavyduty, high-torque DC motors are used for spooling operations. Both motors are equipped with electronic tacho controls. This allows completely contact-free processing of all control and speed adjustment signals.

Im Bandlauf befinden sich zwei Bandzugwaagen, die linke für den linken Wickelteller (SUPPLY MOTOR M1), die rechte für den rechten Wickelteller (TAKE UP MOTOR M2). Damit ist sichergestellt, dass der Bandzug auch bei extremen Wickelverhältnissen vor und nach der Tonwelle erhalten bleibt.

Die Drehbewegung der Bandwaagen wird durch Präzisions-Potentiometer (R-TT1 und R-TT2) abgegriffen; die dem Bandzug proportionalen Spannungen (Ist-Wert) wirken auf die Eingänge der Differentialverstärker (Q2, Q4).

Die Steuerspannungen für normalen, schnellen Vor- und Rücklauf (B-FORW, B-REW) oder für den stufenlos, handgeregelten Cutter-Betrieb (CUTAUT, Regler EDIT gedrückt) wirken auf die Referenz-Eingänge der Differential-Verstärker. Damit wird erreicht, dass die elektronische Bandzug-Regelung auch während den Umspul-Funktionen arbeitet.

Für die verschiedenen Lauffunktionen können die Soll-Werte des Bandzuges an Trimm-Potentiometern eingestellt werden.

Die zusätzlichen Steuersignale für die Startbeschleunigung (Y-ACCEL, sobald der Andruckmagnet angezogen hat) oder STOP (K-BLIFT = "H", Bremsmagnete fallen ab, Wickel werden gebremst) wirken auf die Referenz-Eingänge der Differential-Verstärker.

Wenn der Jumper* eingesteckt ist, steht der rechte Wickelmotor still.

Dem Differential-Eingang Q4 ist eine Schaltstufe zugeordnet (Q1), welche bei Papierkorb-betrieb (fakultativ) den rechten Wickelmotor stoppt, wenn die rechte Bandumlenkrolle stillsteht (YBI-MOVE = "L"). Über Treiberstufen Q14, Q15 werden die Leistungs-Transistoren angesteuert. Diese befinden sich auf dem Leistungs-Transistoren-Feld des Laufwerkchassis. Die Leistungs-Transistoren wirken als stufenlos veränderliche Lastwiderstände in den Brückkreisen D13 und D14.

3.4.5 Wickelmotor-Schützen CONTACTORS

siehe Schaltbild 1.080.381 GR 20 EL 4

Die Steckkarte "Wickelmotor-Schützen" enthält einen 4-poligen Bremsschütz (K1) (K-BRAKE), welcher während der Bremsphase Gleichstrom an die Wickelmotoren schaltet. 2 Bremstransistoren (Q9, Q11) angesteuert durch Q8 bzw. Q10 schalten den geregelten Bremsstrom an den aufwickelnden Wickelmotor.

Das Signal Y-REVRS bestimmt über die Transistoren Q6 und Q7, welche Bremstransistoren den geregelten Bremsstrom erhalten sollen.

Two tape tension sensors are installed in the tape transport system. The left sensor governs the left-hand spooling reel (SUPPLY MOTOR M1), the right unit controls the right-hand spooling reel (TAKE UP MOTOR M2). Even under extreme spooling situations, proper tape tension is maintained before and after the capstan.

The rotation movement of the tape tension sensors is sensed by the precision potentiometers (R-TT1 and R-TT2). The voltages proportional to the tape tension (actual value) are input to the differential amplifier (Q2, Q4).

The control voltages for normal or fast forward or rewind (B-FORW, B-REW) or for the infinitely adjustable, manually regulated cutter operation (CUTAUT, EDIT depressed) act on the reference inputs of the differential amplifiers. In this manner, the electronic tape tension control remains effective also during spooling operations.

The various reference values for the tape transport functions can be adjusted on the trimmer potentiometers.

The additional control signals for start acceleration (Y-ACCEL, as soon as the pinch roller magnet has picked up) or STOP (K-BLIFT = "H", brake magnets drop out, reel is braked) also act on the reference inputs of the differential amplifiers.

When the jumper* is plugged in, the right-hand spooling motor stands still.

The differential input Q4 is associated with a switching stage (Q1) which (optionally) stops the right-hand spooling motor when operating in waste-paper basket mode and when the right-hand tape guide stands still (YBI-MOVE = "L"). The power transistors are selected via driver stages Q14 and Q15. These are mounted on the power transistor board of the drive chassis. The power transistors act as infinitely variable load resistors in the bridge circuits D 13 and D 14.

3.4.5 SPOOLING MOTOR CONTACTORS

(see circuit diagram 1.080.381 GR 20 EL 4)

The plug-in circuit board "CONTACTORS" comprises a 4-pole brake contactor (K1) (K-BRAKE) which transfers DC current to the spooling motors during the braking phase. Two brake transistors (Q9, Q11), selected by Q8 resp. Q10 transfer the regulated brake current to the active spooling motor.

Via transistors Q6 and Q7, signal Y-REVRS determines which brake transistors are to receive the controlled brake current.

Der Schalttransistor (Q14) der Warnblinkschaltung ist durch eine elektronische Sicherung (TRIP CIRCUIT) vor Überlast geschützt.

Weiter ist der Brems-Regelverstärker (DC BRAKE CONTROL) und die Blink-Elektronik (FLASHER UNIT) auf dieser Steckkarte untergebracht.

Brems-Regelverstärker

Der Brems-Regelverstärker besteht aus zwei Differentialstufen und einer Endstufe mit Treiber- und Leistungstransistor.

Das Signal der rechten Bandzugwaage R-TT2 steuert den Differential-Eingang Q1 an und bewirkt die normale Bremsregelung; am Referenz-Eingang Q2 wirkt der am Potentiometer R9 eingestellte Soll-Wert.

Sobald das Band aus der Abwickelspule ausläuft, dreht die Bandwaage R-TT2 in die Nullstellung (geringste Bremsung). In diesem Moment übernimmt die Differentialstufe Q3 und Q4 die Steuerfunktion. Das Endschalter-Signal YBI-END wird "L", die Basisspannung an Q4 sinkt; die Bremsspannung nimmt den maximalen Wert an und der auslaufende (volle) Wickel wird mit maximalem Bremsmoment gestoppt.

Um zu verhindern, dass beim Betrieb mit Klarsichtfolie eine volle Bremsung eintreten könnte bevor das Band ausgelaufen ist, wird an der Basis von Q4 auch die Stellung der Bandzugwaage mitberücksichtigt. Damit volle Bremsung eintritt, muss gleichzeitig mit YBI-END = "L" auch die Bandwaage in Nullstellung stehen (R-TT2 = + 2,6 V).

Schützen

In Bremsfunktion werden beide Wickelmotoren an die Bremsgleichspannung gelegt. Das Signal K-DIR bestimmt, an welchen Motor der geregelte Bremsstrom geführt wird (aufwickelnder Motor). Die Bremsstrom-Regelung erfolgt über die rechte Bandzugwaage. Der Motor der abwickelnden Seite erhält vollen Bremsstrom.

Warnblink-Schaltung

Auf der Steckkarte "Wickelmotor-Schützen" befindet sich auch die Warnblink-Schaltung, welche den Ausfall von Sensor-Leuchtdioden bzw. Lampen (Test-B/B-INDIC) sowie der -5,8 V Speisung optisch signalisiert.

The switching transistor (Q14) of the flashing warning circuit is protected against overload by an electronic fuse (TRIP CIRCUIT).

The variable gain brake amplifier (DC BRAKE CONTROL) and the FLASHER UNIT are also mounted on this card.

Variable gain brake amplifier.

The variable gain brake amplifier consists of two differential stages and an output stage with driver and power transistor.

The signal of the right-hand tape tension sensor R-TT2 controls the differential input Q1 and thereby provides the normal braking control. The nominal value, adjustable on potentiometer R9, acts on the reference input Q2.

As soon as the tape end leaves the supply reel, the tape tension sensor R-TT2 sets itself to zero position (lowest braking force). At this point, control is transferred to differential stages Q3 and Q4. The tape-end signal YBI-END changes to "L", the basic voltage on Q4 drops, the braking voltage assumes maximum value and the terminating (full) reel is stopped with maximum force.

Full braking is not effected before the tape end has left the transport system, even when using transparent tape ends. To accomplish this, the base of Q4 also evaluates the status of the tape tension sensor. Two conditions must simultaneously be met for full braking to become effective: YBI-END must be at "L" and the tape tension sensor at zero (R-TT2 = + 2.6 V).

Contactors

During braking operations, both spooling motors are supplied with DC braking voltage. The signal K-DIR determines, which of the two spooling motors has to receive the controlled current (take-up motor). The brake current is controlled by the right-hand tape tension sensor. The motor driving the supply reel receives full braking current.

Flasher unit

The flasher unit is located on the plug-in circuit board "Spooling Motor Contactors". It provides an optical signal in case of failing sensor LEDs or lamps (Test-B/B-INDIC) or failing - 5.8 V supply voltage.

4. LAUFWERKEINSTELLUNGEN

4.1

MECHANISCHE LAUFWERKEINSTELLUNGEN

Vor den elektrischen und mechanischen Laufwerkeinstellungen sind die Speisespannungen zu kontrollieren (siehe Kap. 4.2.1).

Erforderliche Messgeräte:

Federwaage oder Kontaktor 0 ... 500 gr

Federwaage oder Kontaktor 0 ... 2500 gr

Leerspule, Kern; Bandstück oder Schnur mit einer kleinen Schlaufe an einem Ende, Länge 2 bis 3 m.

4.1.1

Mechanische Bremsen (Fig. 4.1)

Die Bremsung der Wickelmassen erfolgt bei normalem Betrieb vornehmlich durch die geregelte Gleichstrombremsung der Wickelmotoren. Beim Ausfall der Netzspannung treten die mechanischen Servo-Bremsen in Aktion. Diese Bremsen wirken auch bei Bandstillstand bzw. beim Betätigen der Bandwickel von Hand. Es ist daher wesentlich, dass die Bremsmomente richtig eingestellt sind.

Einstellung der mechanischen Bremsen:

1. Das Spiel (1) zwischen Bremshebel und Abhebe-Bolzen soll in Ruhelage 1 mm bis 1,5 mm betragen. Zum Einstellen ist die Trägerplatte zu lösen (Schrauben (8)) und in seitlicher Richtung (2) zu verschieben.
2. Der Hub (3) des Abhebe-Bolzens soll 4 mm betragen. Durch Andrücken des Magnet-Ankers von Hand, kann dieser Hub kontrolliert werden. Zur Hub-Einstellung wird der Bremsmagnet (4) verschoben. Bei abgehobenem Bremsband muss der Wickelmotor frei ohne jede Bremsung drehen.
3. Das richtige Funktionieren der Bremse kann durch kurzes Vor- und Zurückdrehen des Wickeladapters (5) kontrolliert werden. Dabei sollen beide Bremshebel wechselseitig an den Anschlag- bzw. den Abhebe-Bolzen schlagen (schnapperndes Geräusch).

4. TAPE TRANSPORT CALIBRATION

4.1

MECHANICAL TAPE TRANSPORT SETTINGS

The supply voltages (see Chap. 4.2.1) should be checked prior to adjusting electrical and mechanical tape transport settings.

Test instruments required:

Spring balance or contactor 0 ... 500 g

Spring balance or contactor 0 ... 2500 g

Empty reel, core; tape section or string with a small loop at its end, length approx. 2 – 3 m.

4.1.1

Mechanical brakes (fig. 4.1)

In normal operations, the tape reels are primarily braked by applying controlled DC braking current to the spooling motor. In case of power failure, braking occurs with mechanical servo brakes. These brakes are also effective when the tape is stopped or when the reel is turned manually. For this reason it is quite important that the brake torque is properly adjusted.

Adjustment of mechanical brakes:

1. In inactive state, the clearance (1) between brake lever and lifting bolt should measure approx. 1 – 1.5 mm. For recalibration, remove carrier plate (screws (8)) and adjust laterally (2).
2. The stroke (3) of lifting bolt should measure 4mm. Manually press the magnet armature to check the stroke. The brake magnet (4) can be moved to adjust the stroke. With braking tape lifted off, the spooling motor must rotate freely without residual braking force.
3. Correct functioning of the brake can be tested by brief forward and backward rotation of the spooling adaptor (5). The brake levers should alternately hit the detent and the lifting bolt (clicking noise).

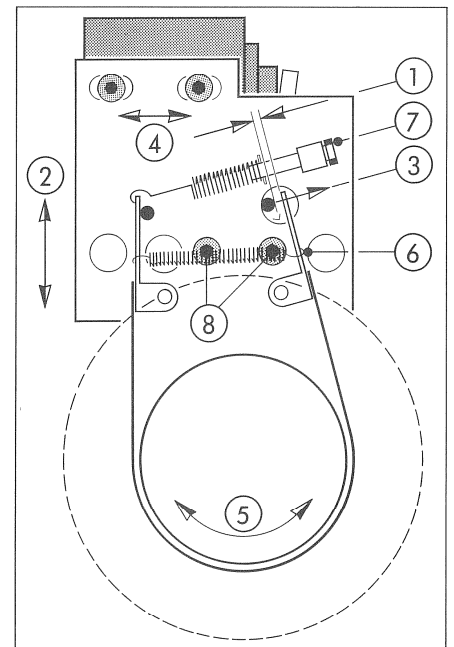

Fig. 4.1

4. Bremszug-Einstellung in Aufwickel-Richtung (schwache Bremsung): Leerspule mit 2 bis 3 m Band oder Schnur in Gegenbetriebslage auf Bandadapter auflegen. Feederwaage (0 ... 500 gr) am Bandanfang einhängen und zur Messung kontinuierlich vorziehen. Durch Umhängen der Feder (6) wird der in Tabelle 4.3 angegebene Bremszug eingestellt.
 5. Bremszug-Einstellung in Abwickel-Richtung (starke Bremsung): Leerspule mit 2 bis 3 m Band oder Schnur in Betriebslage auf Bandadapter legen. Feederwaage (0 ... 500 gr) am Bandanfang einhängen und zur Messung kontinuierlich vorziehen. Mit Schraube (7) wird der in Tabelle 4.3 angegebene Bremszug eingestellt. Nach der Justierung des Federzuges soll der Haken am Ende der Feder horizontal stehen, siehe Fig. 4.1.
4. Brake tension setting in take-up direction (low braking force): Place empty reel containing 2 – 3 m of tape or string in reverse operating direction on tape adaptor. Suspend spring balance (0 ... 500 g) at leading tape end and continuously pull to measure the tension. The nominal value given in table 4.3 is obtained by changing the position of spring (6).
 5. Brake tension setting in supply direction (strong braking force): Place empty reel containing 2 – 3 m of tape or string in operating direction on tape adaptor. Suspend spring balance (0 ... 500 g) at leading tape end and continuously pull to measure the tension. The nominal value given in table 4.3 is obtained by turning spring screw (7). After adjusting the spring tension, the hook at the end of the spring should be in horizontal position (see Fig. 4.1).

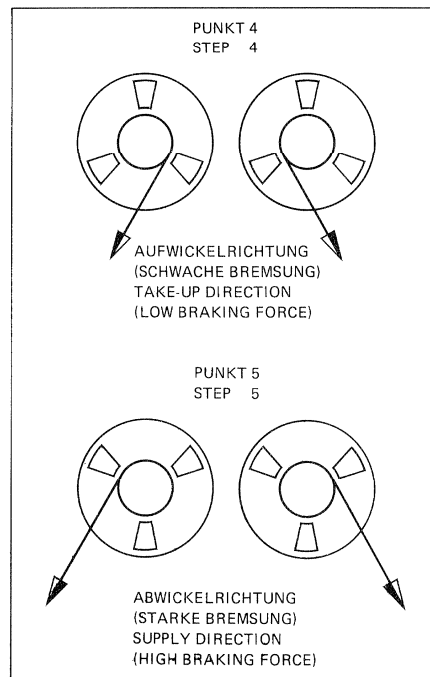

Fig. 4.2

4.1.2 Andruck-Aggregat

Das Andruck-Aggregat besitzt zwei Elektromagnete: Andruckmagnet rechts (2) und EDIT-Magnet links (1). Das System besitzt zwei Arbeitsstellungen. In Stellung PLAY sind die Rollen (9) und (10) ganz eingefahren, die Andruckrolle (10) liegt auf der Tonwelle auf. Für den EDIT-Betrieb fahren die Rollen nicht ganz ein, die Andruckrolle liegt nicht auf der Tonwelle auf.

Für den Bandtransport in Stellung PLAY oder Aufnahme werden in der ersten Phase beide Magnete aktiviert (K-CUT und K-PRESS = "L"). Kurz vor der Endstellung des Andruck-Magnet-ankers schaltet der Micro-Switch (7) (S-ACCEL) auf + 24 V, der EDIT-Magnet wird abgeschaltet und gleichzeitig erhält die Wickelmotor-Steuerung den Startimpuls (Y-ACCEL) für den rechten Wickelmotor.

4.1.2 Pinch-roller assembly

The pinch-roller assembly comprises two electromagnets: right-hand pinch magnet (2) and left-hand EDIT magnet. The system functions with two operating positions. In PLAY position, rollers 9 and 10 are moved in completely and the pinch roller (10) rests on the capstan. In EDIT operations, the pinch rollers do not move in completely and the pinch roller does not touch the capstan.

With the tape transport in PLAY or RECORD position, the two magnets (K-CUT and K-PRESS = "L") are activated in the first phase. Immediately before the pinch-roller magnet armature reaches the limit position, microswitch (7) (S-ACCEL) changes to + 24 V. The EDIT magnet is switched off and the spooling motor control receives the start impulse (Y-ACCEL) for the right-hand spooling motor.





linke Spule/left reel		rechte Spule/right reel	
Aufwickel-Richtung CW 	Abwickel-Richtung CCW 	Abwickel-Richtung CW 	Aufwickel-Richtung CCW 
< 60 p	180 p *	180 p *	< 60 p

Fig. 4.3
Mechanische Bremszüge 1/4" Band (NAB-Kern)
Mechanical braking force 1/4" tape (NAB-hub)

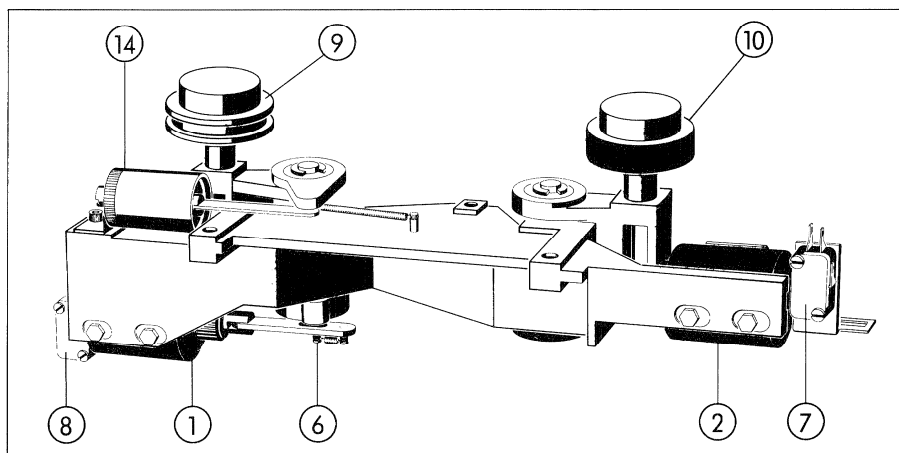

Fig. 4.4

In EDIT-Betrieb wird nur der EDIT-Magnet (1) aktiviert (C-CUT = "L"), die Rollen fahren auf EDIT-Stellung und der Micro-Switch (8) S-TT schaltet auf + 24 V. Da gleichzeitig auch das Signal K-TT = "L" wird, ziehen die Festhalte-magnete der Bandzugwaagen an und blockieren diese.

Einstellung

1. Befestigungsschrauben des EDIT-Magneten (1) lösen und diesen an den linken Anschlag schieben, Schrauben provisorisch wieder festziehen.
2. In Stellung STOP soll der Abstand zwischen Andruckrolle (10) und der Tonwelle (11) 25,4 mm (+ 5/-0) bzw. 1" (+ 0,02"/-0) betragen. Zum Einstellen, Kontermutter (12) lösen und Kupplungsstange (13) drehen. Kontermutter wieder festziehen und kontrollieren, ob die Rollen (9) und (10) beim Ein- und Ausschwenken frei spielen (Fig. 4.5).

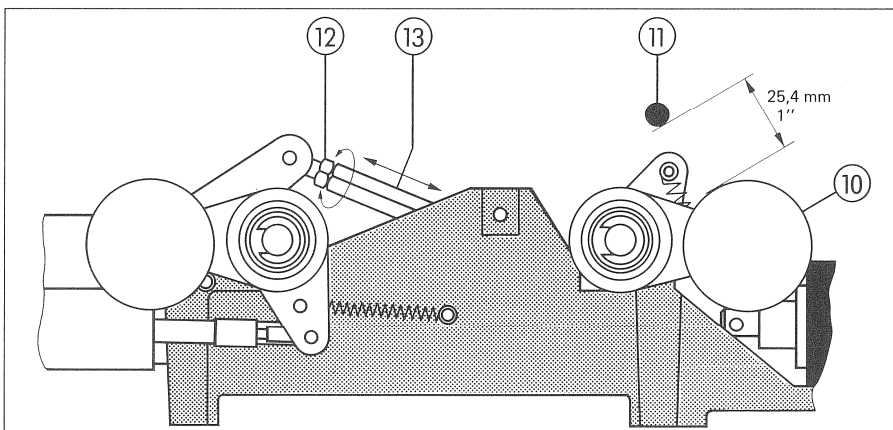

Fig. 4.5

3. Endschalter-Lichtschranke abdecken und Kabelsteckverbindung am Tonmotor auftrennen. Taste PLAY drücken. Befestigungsschrauben des Andruck-Magneten (2) lösen. Kontrollieren, ob der Anker des Andruck-Magneten (2) voll eingefahren ist und am Anschlag steht. Durch seitliches Verschieben des Andruck-Magneten das Spiel (17) zwischen Andruckarm und Andruckhilfsarm auf 0,3 bis 0,5 mm einstellen, so dass nur die Federspannung wirkt. Befestigungsschrauben wieder festziehen. Zur Kontrolle, Andruckrolle von Hand gegen die Tonwelle drücken und wechselweise die Tasten PLAY und STOP betätigen, dabei muss in Stellung PLAY das Spiel (17) sichtbar sein.
In Stellung PLAY (mit aufgesetztem Kopfträger), Bandführungs-Rolle (9) von Hand in Richtung Kopfträger drücken, dabei soll ein Weg von mindestens 1 mm bis zum Anschlag fühlbar sein.

In EDIT mode, only the EDIT magnet (1) is activated (C-CUT = "L"). The rollers move into EDIT position and microswitch (8) S-TT switches to + 24 V. Because signal K-TT simultaneously changes to "L", the stop magnets of the tape tension sensor pick up causing the latter to be blocked.

Calibration

1. Loosen mounting screws (1) of the EDIT magnet and slide the magnet to the left detent. Temporarily retighten screws.
2. The clearance between pinch roller (10) and capstan (11) in STOP position should measure 25.4 mm (+ 0.5/- 0) or 1" (+ 0.02"/- 0). For calibration, loosen check nut (12) and rotate coupling lever (13). Retighten checknut and check that rollers (9) and (10) have free play while sliding in and out (fig. 4.5).

3. Blind optical tape-end sensor and unplug cable to capstan motor. Depress PLAY key. Loosen mounting screw of pinch-roller magnet (2). Check that armature of pinch-roller magnet (2) has travelled in completely and has reached the detent. By lateral shifting of the pinch-roller magnet, the clearance (17) between pinch-roller arm and auxiliary pinch-roller arm can be set to 0.3 - 0.5 mm in which case only the spring tension remains effective. Retighten mounting screw. To check the adjustment, manually press pinch-roller against capstan and alternately depress PLAY and STOP keys. In PLAY mode, the clearance (17) must be visible.
In PLAY position (with head block assembly in place) manually press the tape guide roller (9) towards head block assembly. The play between detent and roller should measure at least 1mm.

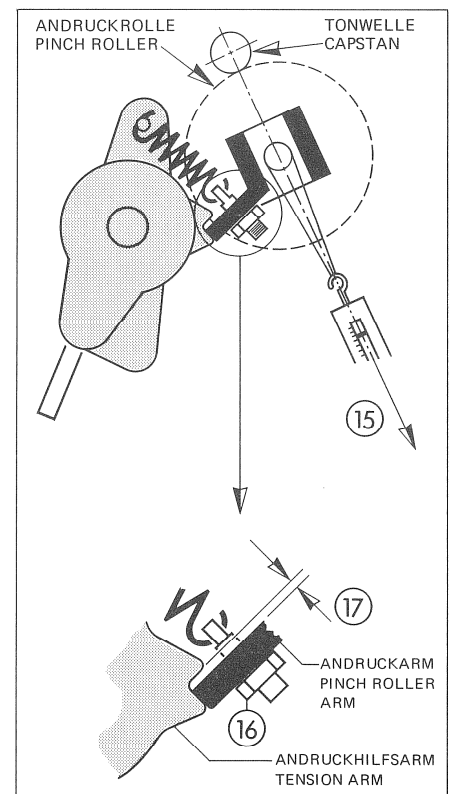

Fig. 4.6

4. An der Andruck-Rollachse Federwaage (0 ... 2,5 kg) einhängen (siehe Fig. 4.6). Taste PLAY drücken und Andruckkraft (15) messen. Die Andruckkraft soll im Moment des Abhebens der Andruckrolle von der Tonwelle $1,2 \pm 0,1$ kp (Fig. 4.6) betragen. Die Justierung erfolgt mit der Sechskantmutter (16) am Andruckarm.
5. Kontrolle, Micro-Switch (Andruckmagnet):
Taste PLAY drücken.
Dieser Micro-Switch soll kurz vor dem Anschlag des Andruck-Magnetankers den EDIT-Magneten abschalten.
Kontrollieren, ob der EDIT-Magnet (1) in Ruhelage ist (Magnetanker muss frei spielen). Ist dies nicht der Fall, muss die Funktion bzw. die Justierung des Micro-Switches (7) (S-ACCEL) auf dem Andruck-Magneten kontrolliert werden.
Zum Justieren sind die zwei Befestigungsschrauben des Micro-Switches zu lösen.
6. Taste PLAY drücken. Befestigungsschrauben des EDIT-Magneten (1) lösen. Den EDIT-Magneten soweit nach rechts schieben, dass ein noch spürbares Spiel von ca. 0,3 bis 0,5 mm zwischen Ankerzugstange und Mitnehmerbolzen (6) verbleibt. Befestigungsschrauben wieder festziehen (Fig. 4.4).

Kontrolle, Stellung EDIT:
Taste EDIT drücken.
Der Abstand zwischen Tonwelle und Andruckrolle (10) soll in dieser Stellung ca. 4 mm betragen.
7. Kontrolle, Micro-Switch (8) (EDIT-Magnet):
Taste EDIT drücken.
Die Festhaltungsmagnete beider Bandzugwaagen müssen jetzt aktiviert sein. Sind die Bandzugwaagen nicht blockiert, so ist die Funktion bzw. die Justierung des Micro-Switches (8) (S-TT) auf dem EDIT-Magneten zu überprüfen.
Der Micro-Switch muss kurz vor dem Anschlag des Magnetankers schalten. Zum Justieren sind die zwei Befestigungsschrauben des Micro-Switches (8) zu lösen.
8. Abdeckung auf dem Foto-Endschalter wieder entfernen. Kabelverbindung zum Tonmotor wieder einstecken.
9. Wiederholt die Taste PLAY drücken und gleichzeitig die pneumatische Dämpfung justieren. Die Justierung erfolgt durch feinfühliges Drehen des Dämpfungszylinders (14), wodurch die Ventilöffnung mehr oder weniger geschlossen wird.
4. Attach spring balance (0 ... 2.5 kg) (see fig. 4.6). Depress PLAY key and measure the pinching force (15). At the point where the pinch-roller lifts off the capstan, the pinching force should measure 1.2 ± 0.1 kp (fig. 4.6). The setting can be adjusted with the hexnut (16) at the pinch-roller arm.
5. Checking of micro switch (pinch-roller magnet):
Depress PLAY key.
The microswitch should switch off the EDIT magnet immediately before the latter reaches the detent of the pinch-magnet armature.
Check that EDIT magnet (1) is in neutral position (magnet armature must have free motion). Should this not be the case, the function or the setting of the micro-switch (7) (S-ACCEL) at the pinch magnet must be checked.
Two mounting screws must be loosened to adjust the microswitch.
6. Depress PLAY key. Loosen mounting screws of the EDIT magnet (1). Shift EDIT magnet to the right until the clearance between armature working stem and carrier bolt (6) remains at 0.3 – 0.5 mm. Retighten mounting screws (fig. 4.4).

Checks in EDIT position:
Depress EDIT key.
The clearance between capstan and pinch-roller (10) in EDIT mode should measure 4 mm.
7. Checking of microswitch (8) (EDIT magnet):
Depress EDIT key.
The stop magnets of the two tape tension sensors should now be activated. If the tape tension sensors are not blocked, the microswitch (8) (S-TT) at the EDIT magnet should be checked.
The microswitch should react immediately before the magnet armature reaches the detent. To adjust, loosen the two mounting screws of the microswitch (8).
8. Remove blinding of the optical tape-end sensor. Restore cable connection to capstan motor.
9. Repetitively depress PLAY and simultaneously adjust the pneumatic cushioning effect. The adjustments are performed by subtle rotation of the pneumatic cylinder (14), causing an increase or decrease in the valve opening.

Bei korrekter Einstellung bewegt sich die Andruckrolle kontinuierlich, ruckfrei in die Wiedergabeposition ohne hart auf die Tonwelle aufzuschlagen.

With correct adjustment, the pinch-roller turns smoothly and without jerking into playback position without slamming against the capstan.

4.1.3 Bandzugwaage

Während den verschiedenen Funktionszuständen wird der Bandzug durch die Auslenkung der Bandzugwaagen und die eingestellte Referenzspannung bestimmt. Der Drehwinkel des Rollentellers wird durch ein mechanisch gekoppeltes Präzisions-Potentiometer (11) in ein analoges elektrisches Signal umgewandelt. Die erforderliche Rückstellkraft der Bandzugwaage wird durch ein Federsystem bewirkt, das zur Erzielung einer annähernd logarithmischen Bandzugkurve zwei verschieden starke Druckfedern plus eine kleine Anschlagfeder enthält.

Ein Scheiben-Dämpfungselement (7) verhindert mechanische Schwingungen des Bandzugwaagensystems.

Damit sich eine gewählte Schnittstelle nicht durch Pendelbewegungen der Bandzugwaagen verschiebt, werden diese in Funktion EDIT durch eingebaute Magnete (5) blockiert.

4.1.3 Tape tension sensor

The tape tension for the various transport functions is determined by the deflection of the tape tension sensor and the value set as nominal voltage. The deflection angle of the roller plate is converted into an analog electrical signal by a mechanically coupled precision potentiometer (11). The restoring force of the tape tension sensor is provided by a spring system. To obtain a nearly logarithmic tape tension curve, two compression springs of different force and a small detent spring are used.

The disc damper (7) prevents mechanical vibrations in the tape tension limiter system.

To prevent shifting of a selected cutting position due to pendular action by the tape tension sensor, the latter are blocked by built-in magnets (5) while operating in EDIT mode.

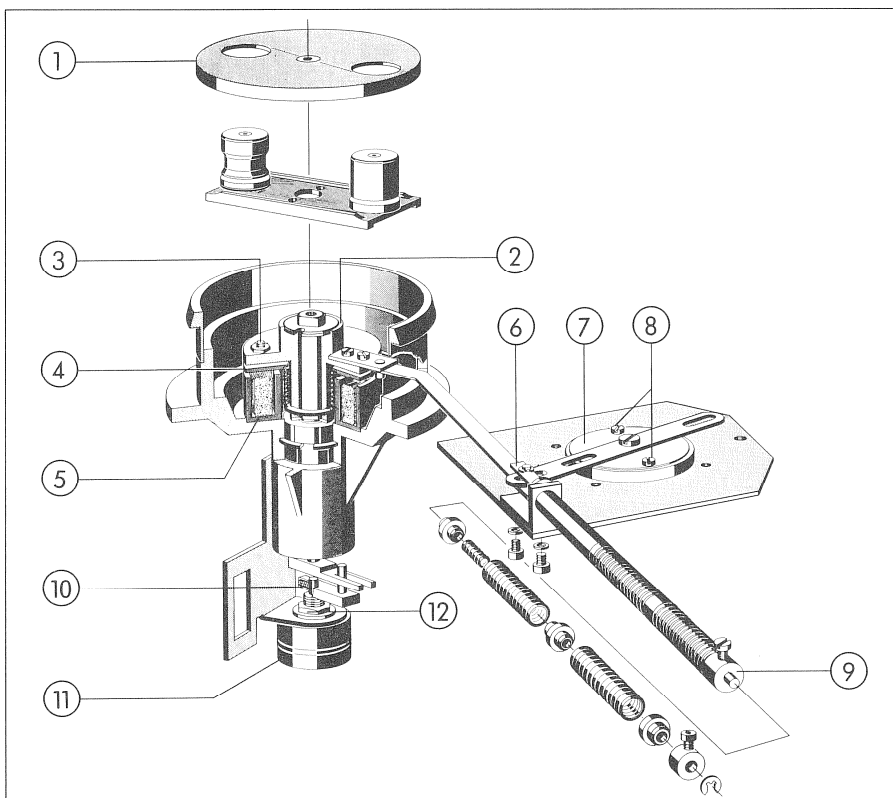

Fig. 4.7

Mechanische Einstellungen der Bandzugwaagen

Fig. 4.7

- Die Senkschraube (1) lösen und den Rollenteller abheben.
Sechskantmuttern der drei Stiftschrauben (3) lösen.
Den Hebelflansch (2) von Hand niederdrücken und die drei Stiftschrauben (3) im Uhrzeigersinn vorsichtig drehen bis die Ankerscheibe (4) gleichmässig auf der Magnetglocke (5) aufliegt.
Die drei Stiftschrauben (3) wieder je um 1/5 Drehung im Gegenuhrzeigersinn lösen, damit sich ein Luftspalt von 0,15 bis 0,2 mm zwischen Ankerscheibe und Magnetglocke ergibt.
Gerät einschalten und durch wechselweises Drücken der Tasten STOP und EDIT das korrekte Blockieren und Lüften der Magnete prüfen.
Stiftschrauben in ihrer Position festhalten und Muttern festziehen.
Rollenteller wieder montieren und vor Festziehen der Schraube (1) die Potentiometerkupplung gegen die Bandwaagen-Ruhestellung drücken. Kontrolle EDIT-STOP wiederholen.
- Den Stellring (9) am Federelement so einstellen, dass sich die Rückzugstange aus jeder Stellung der Bandzugwaage kontinuierlich und ohne zu prellen in die Ruheposition bewegt.

Anmerkung:

Das Verschieben des Stellrings (9) hat zur Folge, dass sich die Endstellung verschiebt. Um zu vermeiden, dass der Drehwinkel der Bandwaage zu gering wird, soll der Stellring höchstens 5 mm in Richtung höherer Rückstellkraft verschoben werden.

Sollte die Dämpfungsdose in einer der angegebenen Positionen trotzdem eine zu geringe oder zu starke Dämpfung aufweisen, so ist die Dämpfungsdose um eine Position in Richtung zum Federgestänge hin bzw. vom Federgestänge entfernt zu verschieben.

Normalstellung = Mittelposition

Richtung Federgestänge = stärkere Dämpfung (bei kürzerem Hebelarm stärkere Dämpfung).

(Feineinstellen durch Drehen des Potentiometers (11), wenn die Mutter (12) lose ist.

- Mit einem Universal-Messinstrument (DC) die Spannung am Potentiometer (11) kontrollieren.
An den Anschlüssen 1 und 3 (blk/org) sollen 20 V anliegen (blk = + 0,0 V). Voltmeter zwischen + 0,0 V (blk) und dem Schleifer (red bzw. brn) anschliessen. In Ruhestellung der Bandzugwaage soll die Spannung am Schleifer 2,6 V betragen. Durch Lösen der Schraube (10) an der

Mechanical adjustment of the tape tension sensor. (fig. 4.7)

- Loosen countersunk screw (1) and lift off roller disk.
Loosen hexnut of the three set screws (3). Manually depress lever flange and carefully rotate set screws (3) in a clockwise direction until armature disk (4) rests evenly on the bell-shaped magnet yoke (5).
Turn each of the three set screws (3) by 1/5th rotation in a counter-clockwise direction which should result in a clearance of 0.15 to 0.2 mm between armature disk and magnet yoke.
Turn on machine and check the correct blocking and lifting of the magnets by alternately pressing the STOP and EDIT keys.
Retain set screws in their position and tighten nuts.
Re-install roller disk and press potentiometer clutch against the tape tension sensor in neutral position prior to tightening screw (1). Repeat EDIT-STOP check.
- Adjust setting ring (9) at spring assembly until the retraction pin moves smoothly into its neutral location from any position of the tape tension sensor.

Note:

Moving the set ring (9) will cause a shifting of the limit position. To prevent the angle of rotation in the tape tension sensor from becoming too small, the set ring may be shifted in the direction of higher restoring force by a maximum of 5 mm.

If the cushioning capsule should provide an excessive or inadequate cushioning effect when the above adjustments have been performed, the capsule may be moved by one position closer or away from the spring rods.

Normal position = center position.

Closer to spring rods = increased cushioning (stronger cushioning with shorter lever).

(Fine adjustment by turning potentiometer (11) with nut (12) loosened).

- Check (DC) voltage at potentiometer (11) with a multimeter.
20 V should be measured at terminals 1 and 3 (black/orange) (black = + 0.0 V). Connect voltmeter between + 0.0 V (black) and the slider (red or brown). With the tape tension sensor in neutral position, the voltage at the slider should measure 2.6 V. The slider setting can be adjusted by loosening screw (10) at the potentiometer

Potentiometerkupplung kann die Schleiferstellung justiert werden.
Bandzugwaage an den Anschlag drehen; die Spannung am Schleifer soll ca. 6 V betragen.

Wichtig:

Das Dämpfungselement darf nicht zerlegt werden, da es mit einem Spezial-Silikonfett gefüllt ist. Durch das unvermeidliche Auslaufen von Silikonfett würde die einwandfreie Funktion des Dämpfungselementes beeinträchtigt.

4.2

Elektrische Einstellungen

Erforderliche Messgeräte:

Universal-Messinstrument (DC),
4 ... 5 Ohm Widerstand, 50 ... 70 Watt,
Federwaage oder Kontaktor 0 ... 500 gr,
Bandstück mit einer kleinen Schlaufe an einem Ende, Leerspule, volle Spule
Verlängerungsprint 21.080.941

4.2.1

Stabilisator (voltage regulator)

Vor den elektrischen und mechanischen Einstellungen am Laufwerk sind die Speisespannungen zu kontrollieren und zu justieren.

Die Speisespannungen werden an den Testpunkten 1 bis 5 der Stabilisator-Steckkarte gemessen und an den Trimm-Potentiometern R33 für + 20,0 V sowie R10 für $\pm 5,8$ V eingestellt.

Am Potentiometer R28 wird die Strombegrenzung der + 20/+ 24 V Speisung eingestellt.

Zur Messung ist ein Ampere-Meter (Bereich > 4 A) in Reihe mit 4 bis 5 Ohm Widerstand (50 ... 75 Watt) an die Sammelschienen + 0,0 V und + 24,0 V auf der Rückseite des Steckkarten-Chassis anzuschließen.

Maschine einschalten, Funktion STOP.

Das Potentiometer R28 (I-MAX) so einstellen, dass das Ampere-Meter 4 A anzeigt.

Wichtig

Diese Messung darf nicht an den Steckkarten-Testpunkten vorgenommen werden.

Achtung:

Die Stabilisierung der + 20 V und + 24 V Speisung enthält Automatikkreise für die Strombegrenzung und die Abschaltung bei Kurzschluss.

Bei Kurzschluss schaltet die Stabilisierung die Speisespannung + 20 V und + 24 V vollständig ab. Die Speisespannungen bleiben auch dann weiterhin abgeschaltet, nachdem der Kurzschluss entfernt wurde.

coupling.

Press tape tension sensor towards detent.
The voltage at the slider should measure approx. 6 V.

Important:

The cushioning element may not be disassembled because it is filled with a special silicon grease. By opening the unit, grease will inevitably leak out thereby adversely affecting the proper functioning of the element.

4.2

ELECTRICAL SETTING

Measuring instruments required:

Multimeter (DC)
4 ... 5 ohms resistor, 50 ... 70 watts
Spring balance or contactor 0 ... 500 g
Tape section with a small loop at one end
Empty reel, full reel
Extension PCB 21.080.941

4.2.1

Voltage regulator

The supply voltages are to be checked and calibrated before making adjustments to mechanical settings in the tape transport system.

The supply voltages are measured at test points 1 to 5 of the voltage regulator plug-in circuit board and adjusted at the trimmer-potentiometers R33 for + 20.0 V and R10 for ± 5.8 V.

The current limitation for the + 20/+ 24 V supply is adjusted at potentiometer R28.

An ammeter with a measuring-range > 4 A is connected in series with a 4 to 5 ohms resistor (50 ... 75 W) to the busbar + 0.0 V and + 24.0 V located on the back of the card rack.

Switch on machine and select STOP function. Adjust potentiometer R28 (I-MAX) until ammeter shows 4 A.

Important:

This measurement may not be taken at test points of the plug-in circuit board.

Caution:

The stabilization of the + 20 V and + 24 V supply comprises an automatic circuit for current limitation and switch-off for short circuits.

In case of a short circuit, the voltage regulator completely cuts off the + 20 V and + 24 V supply. The supply voltage remains switched off even after the short circuit has been removed.

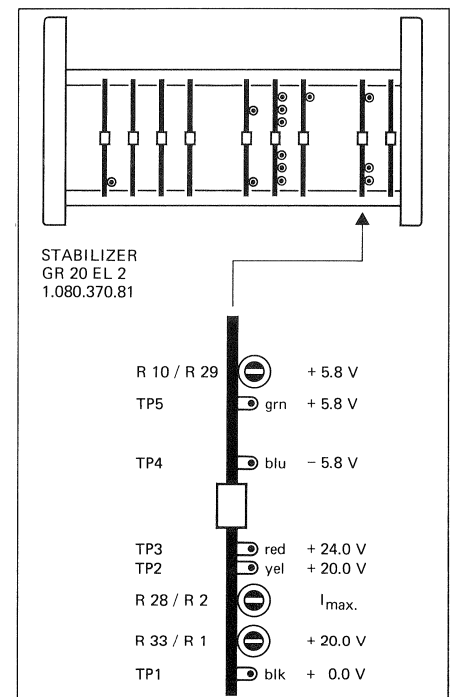

Fig. 4.8

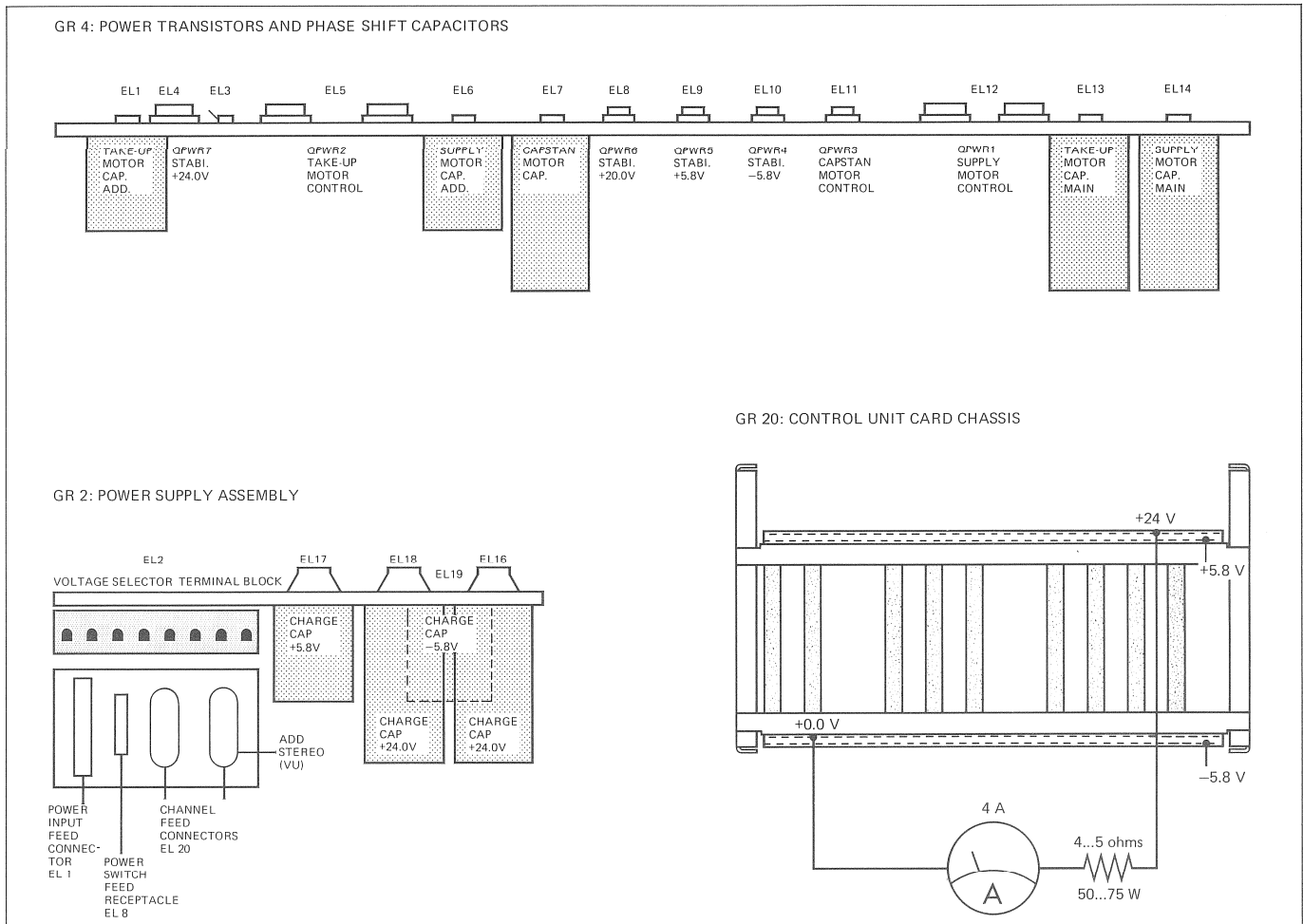

Fig. 4.9

Die Stabilisierung arbeitet erst wieder normal, wenn das Gerat mindestens 15 Sekunden ausgeschaltet war.

The voltage regulator does not resume its function until the machine has been switched off for at least 15 seconds.

Ferner erlaubt es die Charakteristik dieser Schutzschaltung nicht, das Gerat ber einen Netz-Regeltransformer langsam von 0 V unter Spannung zu setzen.

In addition, the layout of this protection circuit does not permit a gradual increase of the main power from 0 V with the aid of a variable AC transformer.

(Die Einschaltspannung muss mindestens die halbe Netz-Anschlussspannung betragen.)

(The starting voltage must reach at least 50% of the mains voltage).

Bandzug-Einstellungen (4.2.2 bis 4.2.4)

Die Bandzüge der Wickelmotoren werden mit den Einstell-Reglern auf der Steckkarte Wickel-motor-Steuerung (SPOOLING MOTOR CONTROL) 1.080.385 abgeglichen. Die oberen Einstell-Regler betreffen den rechten Wickel-motor, die unteren den linken Wickel-motor.

Wichtig:

Vor Beginn der Bandzug-Einstellungen ist zu kontrollieren, ob die Bandzugwaagen richtig ein-gestellt sind. (Siehe Abschnitt 4.1.3)

Ferner ist es wichtig, dass die verschiedenen Bandzug-Einstellungen in der aufgeführten Rei-henfolge durchgeführt werden, da sie sich gegen-seitig beeinflussen.

Tape tension settings (4.2.2 to 4.2.4)

The tape tensions of the spooling motors are balanced at the adjustable potentiometers loca-ted on the plug-in circuit board SPOOLING MOTOR CONTROL 1.080.385. The upper potentiometers apply to the right-hand spooling motor, the lower potentiometers the left-hand spooling motor.

Important:

Before testing the tape tension settings, check whether the tape tension limiter is properly adjusted (see Chap. 4.1.3).

Because of their interaction, it is necessary that the various tape tension adjustments be performed in the sequence listed.

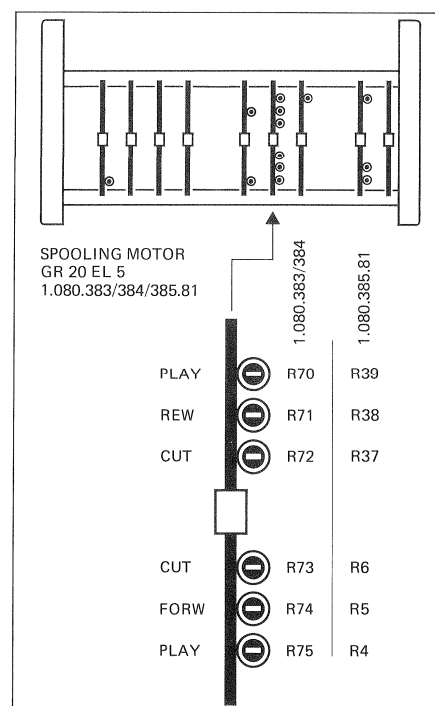

Fig. 4.10

4.2.2

Einstellen mit Bandzugmessgerät (Tentelometer)

Die oben beschriebene Einstellung kann auch mit einem Bandzugmessgerät ausgeführt werden.

- Auf der Auf- und Abwickelspule muss sich etwa gleich viel Band befinden.
- Es sollten auf beiden Seiten die gleichen Spulen (Material, Durchmesser) verwendet werden.
- Mit einem Bandzugmessgerät wird der Bandzug vor dem Aufnahmekopf mit Potentiometer R70 auf 100 p eingestellt (linker Wickel-motor).
- Auf die gleiche Art wird auch der rechte Wickel-motor eingestellt.

4.2.2

Adjusting with tentelometer

The previously described adjustment can also be performed with the aid of a tentelometer.

- Supply and take-up reel should contain an approximately equal length of tape.
- Both sides should be fitted with the same type of reel (material, diameter).
- The tape tension is measured with the tentelometer ahead of the recording head with the aid of potentiometer R70 set at 100 p (left-hand spooling motor).
- The procedure is repeated for the right-hand spooling motor.

4.2.3

Bandzug Wiedergabe

1. Bandzug-Einstellung linker Wickel-motor (SUPPLY): NAB-Leerspule mit ca. 2 bis 3 m Band auf den linken Wickel-adapter auflegen. Bandanfang bis zum Auf-nahmekopf einschlaufen¹ und Federwaage (0 ... 500 gr) am Bandanfang einhängen (Fig. 4.11).

Federwaage festhalten und Taste PLAY drücken. Federwaage in Bandlaufrichtung kontinuierlich vorziehen (Band darf die Gummi-Andruckrolle nicht berühren).

4.2.3

Tape tension for playback

1. Tape tension setting for left-hand spooling motor (SUPPLY). Mount NAB reel containing approx. 2 to 3 m of tape on the left-hand reel adaptor. Thread tape to record head and attach spring scale (0 ... 500 p) at leading tape section (fig. 4.11).

Hold spring scale while depressing PLAY key. Pull spring scale gradually forward (tape should not touch rubber pinch roller)

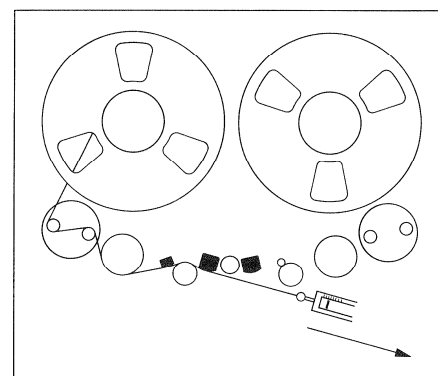

Fig. 4.11

An R70 (SUPPLY, TT-PLAY) Bandzug nach Tabelle 4.12 einstellen.

2. Bandzug-Einstellungen rechter Wickelmotor (TAKE-UP):
Volle Bandspule (10,5'') auflegen, Band normal einlegen und vorspulen bis sich auf der Vorrats- und Aufwickelspule etwa gleich viel Band befindet. Taste PLAY drücken. Sobald sich das Band bewegt, den Andruckarm zurückziehen (ohne die Andruckrolle zu berühren) bis das Band den Kontakt mit der Tonwelle verliert.

Bandzug des rechten Wickelmotors an R75 (TAKE-UP, TT-PLAY) so einstellen, dass das Band nach dem Abheben der Andruckrolle langsam zum Stillstand kommt.

Durch wiederholtes Kontrollieren ist die Richtigkeit der Einstellung zu prüfen.

(Das Abheben kann am Andruckarm erfolgen. Bei montierter Abdeckung, Andruckrollendeckel abschrauben und zum Abheben einen Innensechskantschlüssel in die Axialschraube stecken. Die Andruckrolle darf dabei nicht gebremst werden.)

Set R70 (SUPPLY, TT-PLAY) tape tension according to table 4.12.

2. Tape tension setting for right-hand spooling motor (TAKE-UP):
Mount full tape reel (10.5''), thread tape in normal manner and wind forward until the take-up reel contains as much tape as the supply reel. Depress PLAY key. As soon as tape begins to move, pull back pinch-roller arm (without touching the pinch-roller) until the tape loses contact with the capstan.

Adjust tape tension of the right-hand spooling motor at R75 (TAKE-UP, TT-PLAY) in such a fashion, that the tape slowly stops after the pinch-rollers are lifted off.

The correctness of the setting is to be verified by repeating the test.

(The pinch-rollers can be lifted at the pinch-roller arm. If the pinch-roller cover is still in place, unscrew it. For lifting the arm, insert an allenhead wrench into the axial screw. The pinch-roller may not be braked).

4.2.4

Bandzugbegrenzung schnelles Umspulen

An den Einstellreglern R71 und R74 ist die maximale Belastung des Bandes beim schnellen Umspulen einstellbar; diese ergibt sich beim Start zum schnellen Umspulen (während der Beschleunigungsphase) oder bei der Richtungsänderung während dem schnellen Umspulen.

Bei der Wahl des maximalen Bandzuges ist zu beachten: Eine starke Beschleunigung erfordert einen hohen Spitzenbandzugwert.

Bei niedriger Beschleunigung und entsprechend besserer Schonung des Bandmaterials, werden zwangsläufig die Reaktionszeiten bei den Umpulfunktionen länger.

Bandzug-Begrenzung, schnelles Vorspulen (FORW)

Etwa 50 m Band auf die rechte Bandspule vorspulen. Rechts Bandzugwaage von Hand in Gegenuhreigerrichtung drehen, bis zur federnden Endstellung. Rechte Bandzugwaage in dieser Stellung festhalten. Taste FORW drücken. Einstellregler R74 (TAKE-UP, TT-FORW) so einstellen, dass das Band stillsteht.

Bandzug-Begrenzung, schnelles Rückspulen (REW)

Band vorspulen bis sich auf der linken Bandspule nur noch etwa 50 m Band befinden. Linke Bandzugwaage von Hand im Uhrzeigersinn bis zur federnden Endstellung drehen und in dieser Stellung festhalten. Taste REW drücken. Ein-

4.2.4

Tape tension limitation during fast wind

The maximum tension applied to the tape during fast winding action can be adjusted at potentiometers R71 and R74.

Maximum load occurs during the acceleration phase of the fast wind or when changing direction in fast wind mode.

The following should be observed when adjusting the peak tape tension: Fast acceleration requires a high peak tape tension setting. At slower accelerations, the reaction time during rewind becomes longer, but the tape material is treated more gently.

Tape tension limitation, fast forward (FORW)

Forward the tape until the right-hand tape reel contains approx. 50 m of tape. Rotate the right-hand tape tension sensor in counter-clockwise direction until the spring detent is reached. Retain the tape tension sensor in this position. Depress FORW key. Adjust potentiometer R74 (TAKE-UP, TT-FORW) until tape stands still.

Peak tape tension limitation, fast rewind (REW)

Forward tape, until the left-hand reel contains only approx. 50 m of tape. Manually rotate left-hand tape tension sensor in clockwise direction until the spring detent is reached. Retain in this position. Depress REW key. Adjust potentiometer R71 (SUPPLY, TT-REW) until

stellregler R71 (SUPPLY, TT-REW) so einstellen, dass das Band stillsteht.

tape stands still.

4.2.5

Bandzugbegrenzung EDIT (CUTAUT)

Betreffend maximalem Bandzug beim handge-regelten Umspulen mit dem Regler EDIT, gelten grundsätzlich dieselben Regeln wie für schnelles Umspulen.

Wichtig:

Bevor die Einstellungen des EDIT-Bandzuges ausgeführt werden, muss der Bandzug in PLAY-Funktion richtig eingestellt sein.

1. Volle Bandspule (10,5") auflegen und vor-spulen bis sich auf der Vorrats- und Auf-wickelspule etwa gleich viel Band befindet.
2. Maschine auf PLAY starten und auf beiden Bandzugwaagen mit einem Bleistift die PLAY-Position anzeichnen.
3. Maschine stoppen, auf den Deckeln der beiden Bandzugwaagen 1 cm von der PLAY-Marke in Richtung höherer Feder-rückstellkraft eine neue Marke setzen.
4. Taste EDIT drücken, den Regler EDIT im Gegenuhrzeigersinn drehen, bis der Micro-switch schaltet. Das Potentiometer R72 ab-gleichen, bis sich die Markierungen auf der linken Bandzugwaage (1 cm über PLAY-Position) decken.
5. Den EDIT-Regler im Uhrzeigersinn drehen, bis der Microswitch schaltet. Mit Potentiometer R73 den gleichen Abgleich wie unter Punkt 4 für die rechte Bandzugwaage durchführen.

4.2.5

Peak tape tension limitation EDIT (CUTAUT)

For manual winding, basically the same rules apply to peak tape tension as for fast wind.

Important:

Before adjusting the settings of the peak tape tension for EDIT mode, the tape tension in PLAY mode must be adjusted correctly.

1. Mount full tape reel (10.5") and wind forward until the supply reel and take-up reel contain approximately the same amount of tape.
2. Start machine in PLAY mode and mark the PLAY position at the tape tension sensor with a pencil.
3. Stop machine and affix a new marking on the covers of the two tape tension sensors, approx. 1 cm away from the PLAY marking in the direction of increased restoring force.
4. Depress EDIT key and rotate EDIT control knob in counter-clockwise direction until the microswitch reacts. Adjust potentiometer R72 until the markings on the left-hand tape tension sensor are aligned (1 cm above PLAY position).
5. Turn EDIT knob in clockwise direction until the microswitch reacts. Make the same adjustments on potentiometer R73 as stated under step 4 above to adjust the right-hand tape tension sensor.

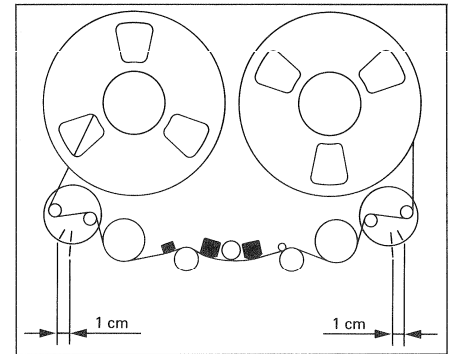

Fig. 4.13

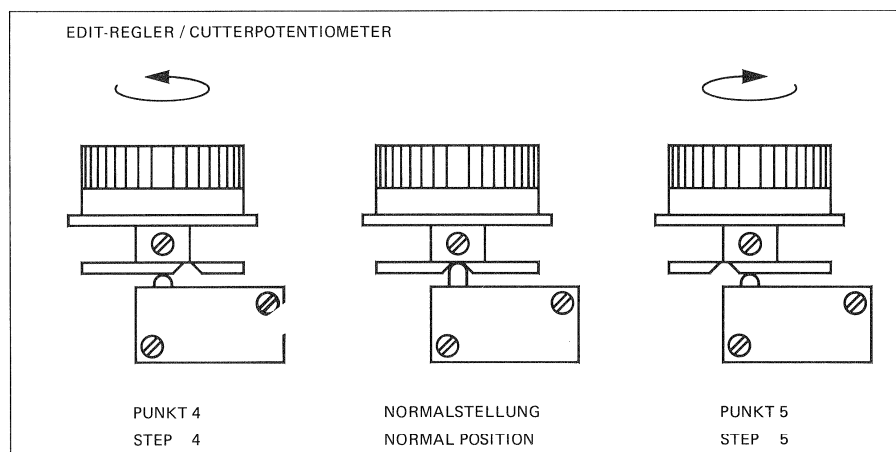

Fig. 4.14

6. In diesen Stellungen (Punkt 4 + 5) sollte das Bandverhalten symmetrisch sein und darf höchstens langsam in die jeweilige Richtung laufen. Die Umspülzeit in EDIT-Betrieb ist von der jeweiligen Einstellung und Betriebsart* abhängig.
- Schnelle Beschleunigung und kurze Umspülzeit erfordert höheren Bandzug.
 - Langsame Beschleunigung und längere Umspülzeiten erfordern kleinere Bandzüge.

- * nur Umspülen in EDIT
- Suchen mit gedrückter EDIT-Taste
 - Suchen mit eingefahrenem rechten Schieber

4.2.6

Bremsregelung

Die folgende Einstellung der Bremsregelung basiert auf dem Bandzug für Wiedergabe. Es ist daher wesentlich, dass vor der Einstellung der Bremsregelung die Bandzüge für Wiedergabe (4.2.3) richtig eingestellt sind.

Die Bremsregelung tritt in Aktion, wenn aus Stellung schnelles Umspülen oder PLAY die Taste STOP gedrückt wird (K-BRAKE). Dabei wird die rechte Bandwaage (T-TT2) als Regelglied (SENSOR) verwendet.

In Abhängigkeit der Bandbewegungsrichtung wird der Wickelmotor der jeweiligen Aufwickelseite in den Stromkreis der Bremsregelung geschaltet.

Der bei der Bremsung auftretende Bandzug lässt sich an R9 begrenzen.

(Der Begrenzungspunkt ist abhängig vom Drehwinkel der rechten Bandzugwaage und der an R9 eingestellten Referenzspannung.)

Mit Hilfe eines Universalinstrumentes lässt sich die Bremsspannung nach Fig. 4.15 einstellen.

Einstellung

Volle Bandschleife auflegen und ca. 10 bis 20 m Band vorspulen. Taste PLAY drücken und die sich dabei ergebende Stellung der rechten Bandwaage markieren. Band abnehmen. Messinstrument an den Testpunkten TP2 (yel, –) und TP3 (wht, +) anschließen (Messbereich > 20 V).

Zur Simulation des Bandlaufes ist der Bandbewegungssensor mit einem Gummiband, welches über die Tonwelle und die rechte Umlenkrolle gelegt wird, anzutreiben.

Kurzzeitig Taste REW oder FORW drücken.

6. After performing steps 4 and 5 above, the tape movement characteristics should be symmetrical and may spool only slowly in the direction selected. The spooling time in EDIT mode is dependent on the settings and function.*
- Fast acceleration and short rewind times require higher tape tension.
 - Slow acceleration and longer rewind times require lower tape tension.

- Fast wind only in EDIT mode.
- Search with EDIT key depressed.
- Search with right-hand slider pushed in.

4.2.6

Brake adjustments

The following adjustments to the brake control system are based on the tape tension for playback mode. For this reason it is crucial that the tape tensions for playback (4.2.3) are properly set before making adjustments to the electronic brake control system.

The brake control is activated when pressing the STOP key while running in PLAY or fast wind mode (K-BRAKE). The right-hand tension sensor (T-TT2) is used as sensor element (SENSOR).

Depending on the direction of the tape motion, the spooling motor of the corresponding winding side is switched in the current circuit of the electronic brake control system.

The peak tape tension occurring during braking action can be limited with adjustable potentiometer R9.

(The point of limitation depends on the winding reel of the right-hand tape tension sensor and the reference voltage set at R9).

The braking voltage according to fig. 4.15 can be set with the aid of a multimeter.

Adjustment procedure

Mount full tape reel and wind tape forward by approx. 10 – 20 m. Depress PLAY key and mark the resulting position of the right-hand tape tension sensor. Remove tape. Connect measuring instrument (range > 20 V) to test points TP2 (yel. –) and TP3 (wht +).

To simulate tape motion, the tape motion sensor is to be rotated by placing a rubber band across the capstan and the right-hand guide roller.

Briefly depress REW or FORW key.

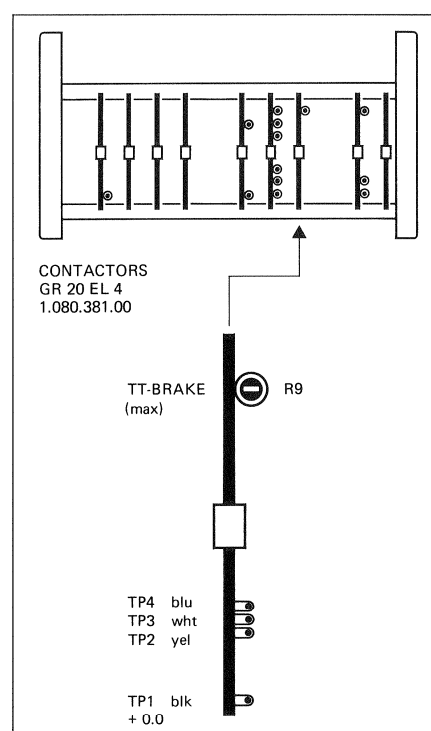

Fig. 4.15

Achtung:

Gerät nicht länger als 2 Minuten in Bremsstellung halten. Zum Aufheben der Bremsstellung, rechte Umlenkrolle (Bandbewegungssensor) stoppen.

Rechte Bandzugwaage in die zuvor markierte Stellung drehen. Einstellregler R9 auf eine Messinstrument-Anzeige von 4 V einstellen.

Durch Bewegen der rechten Bandwaage kontrollieren, ob das Regelsignal der in Abbildung 4.16 dargestellten Kurve entspricht.

Bei ansprechendem Fotoendschalter (Lichtschranke nicht abgedeckt) und Ruhestellung der Bandzugwaage tritt volle Bremsung für beide Motoren ein, bis die rechte Bandumlenkrolle stillsteht, d.h. YBI-MOVE "L" wird.

4.2.7

Tonmotorregelung, Abgleich

Die Tonmotor-Einheit enthält zwei um 180° versetzte Abtastköpfe. Diese Anordnung dient zur Kompensation drehzahlabhängiger Tonhöenschwankungen, welche durch minimale Exzentrizität oder Teilungsfehler im Nutenraster (verbleibende Ungenauigkeiten innerhalb sehr enger Bearbeitungstoleranzen) hervorgerufen werden können.

Die Ungenauigkeit beträgt bei entsprechender Geschwindigkeit:

9,5 cm/s	3,33 Hz
19 cm/s	6,66 Hz
38 cm/s	13,33 Hz
76 cm/s	26,66 Hz

Einstellung 1.080.372/374/377

1. Volle Spule auflegen und Band einlegen. An den Testpunkten TP1 (blk, +0,0 V) und TP2 (wht, 800 Hz) einen Digital-Frequenzzähler anschliessen. Taste PLAY drücken. Am Einstellregler R27 justieren bis der Zähler eine Frequenz von 800 Hz ± 0,2 Hz anzeigt.

9,5 / 19 cm/s	=	400 Hz ± 0,5 Hz
19 / 38 cm/s	=	800 Hz ± 0,5 Hz
38 / 76 cm/s	=	1600 Hz ± 1 Hz

2. Die eingangs erwähnten Tonhöenschwankungen können mit dem Einstellregler R45 (TACHO HEAD) kompensiert werden (Einstellung bei langsamer Bandgeschwindigkeit vornehmen).

Wichtig:

Die Kompensation an R45 ist nur messbar, wenn alle anderen Komponenten im Bandlauf weniger Tonhöenschwankungen verursachen.

Caution:

Do not keep machine in braking mode for longer than 2 minutes. To stop braking action, stop right-hand guide roller (tape motion sensor).

Turn right-hand tape tension sensor in to previously marked position. Use a voltmeter to adjust potentiometer R9 to a reading of 4 V.

Check that the control signal corresponds with the curve shown in Fig. 4.16 by moving the right-hand tape tension sensor.

When the optical tape end sensor reacts (light barrier not covered) full braking action occurs for both motors until the right-hand guide roller stops i.e. YBI-MOVE "L".

4.2.7

Capstan motor servo balancing

The capstan drive unit comprises two scanning heads, offset by 180°. This arrangement serves to compensate speed-related wow and flutter which can be caused by minimal eccentricity or division inaccuracy in the groove pattern (residual inaccuracy within very close machining tolerances).

The inaccuracy at the corresponding tape speed is as follows:

3.75 ips	3.33 Hz
7.5 ips	6.66 Hz
15 ips	13.33 Hz
30 ips	26.66 Hz

Adjustment of PCB 1.080.372/374/377

1. Mount full reel and thread tape. Connect a digital frequency counter to test points TP1 (blk, +0.0 V) and TP2 (wht, 800 Hz). Depress PLAY key. Adjust potentiometer R27 until the counter displays a frequency of 800 Hz ± 0.2 Hz.

3.75/7.5 ips	=	400 Hz ± 0.5 Hz
7.5/15 ips	=	800 Hz ± 0.5 Hz
15/30 ips	=	1600 Hz ± 1 Hz

2. The previously mentioned wow and flutter can be compensated with the adjustable potentiometer R45 (TACHO HEAD). (Adjustment to be made at low tape speed)

Important:

Compensation at R45 is only measurable when all other components in the tape transport produce a lesser amount of wow and flutter.

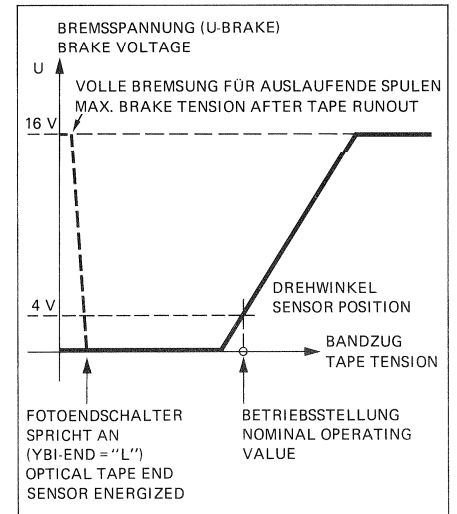

Fig. 4.16

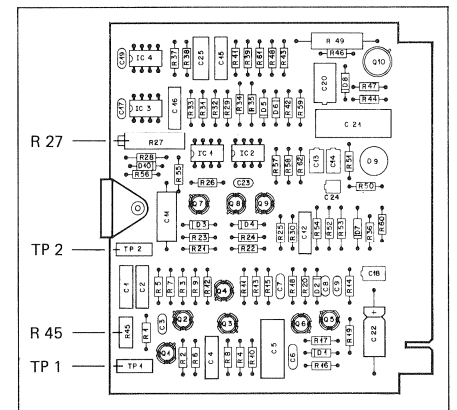

Fig. 4.17

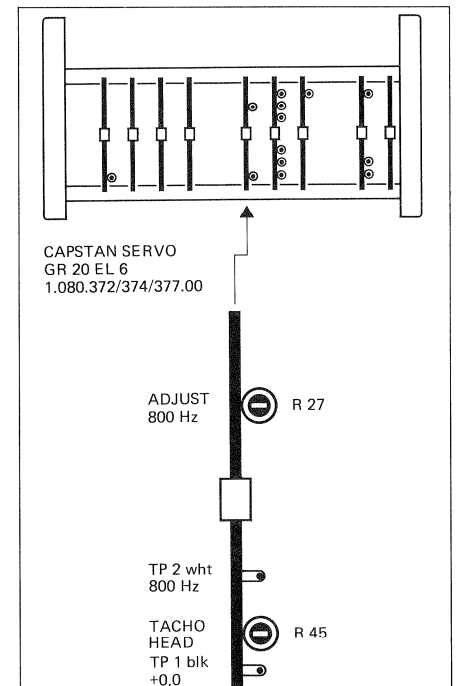

Fig. 4.18

4.2.8

Tonmotor Regelung, Abgleich 1.080.376

Die Tonmotor-Einheit enthält zwei um 180° versetzte Abtastköpfe. Diese Anordnung dient zur Kompensation von drehzahlabhängigen Tonhöhen-schwankungen von 6,66 bzw. 13,33 Hz, welche durch minimale Exzentrizität oder Teilungsfehler im Nutenraster (verbleibende Ungenauigkeiten innerhalb sehr enger Bearbeitungstoleranzen) hervorgerufen werden können.

Einstellung

1. Zuerst wird der Abtastkopf auf der Steckerseite eingestellt. Beide Nylonschrauben lösen und den Abtastkopf so einstellen, dass ein Luftspalt von 0,5 mm verbleibt. (Ein zu schmaler Luftspalt verursacht mechanische Pfeifstörungen.)

Den Einstellregler R45 (TACHO HEAD) in die Mittelstellung drehen. An die Ausgänge der Abtastköpfe ein Zweistrahl-Oszilloskop anschliessen. (Steckerleiste Capstan Servo 1.081.376, Anschlussstifte 3 A/5 A bzw. 4 A/6 A.) Bei 19 cm/s (7,5 ips) Bandgeschwindigkeit soll das Tacho-Signal mindestens 50 mV effektiv (ca. 150 mV Spitze-Spitze) betragen. Bei zu geringem Signal ist der Luftspalt zu verkleinern. Den zweiten Abtastkopf anschliessend auf gleiche Amplitude und identische Phasenlage einstellen.

Wichtig:

Das Verhältnis von Tachosignal zu überlagerter Brummspannung soll mindestens 20 dB (10 : 1) betragen.

2. Volle Spule auflegen und Band einfahren. An den Testpunkten TP1 (blk, +0,0 V) und TP2 (wht, 800 Hz) einen Digital-Frequenzzähler anschliessen. Taste PLAY drücken. Am Einstellregler L1 justieren bis der Zähler eine Frequenz von 800 Hz \pm 0,5 Hz anzeigt.

Für Geräte mit der Geschwindigkeit 38/76 cm/s beträgt die Frequenz 1600 Hz \pm 1 Hz.

3. Die eingangs erwähnten Tonhöhen-schwankungen können mit dem Einstellregler R45 (TACHO HEAD) kompensiert werden (Einstellung bei 7,5 ips Bandgeschwindigkeit vornehmen).

Wichtig:

Die Kompensation an R45 ist nur messbar, wenn alle anderen Komponenten im Bandlauf weniger Tonhöhen-schwankungen verursachen.

4.2.8

Capstan motor servo balancing, circuit 1.080.376

The capstan drive unit comprises two scanning heads, offset by 180°. This arrangement serves to compensate speed-related wow and flutter of 6.66 or 13.33 Hz which can be caused by minimal eccentricity or division inaccuracy in the groove pattern (residual inaccuracy within very close machining tolerances).

Adjustment

1. First, adjust the scanning head facing the plug. Loosen both nylon screws and calibrate scanning head in such a fashion, that an air gap of 0.5 mm remains (a narrower air gap will cause mechanical whistling noises).

Turn potentiometer screw at R45 (TACHO HEAD) towards center position. Connect a two-beam oscilloscope to the outputs of the scanning heads (plug strip for Capstan Servo 1.081.376, connection pin 3A/5A resp. 4A/6A). At (7.5 ips) (19 cm/s) tape speed, the tacho signal should measure at least 50 mV (approx. 150 mV peak to peak). If the signal is too weak, the air gap must be reduced. Connect the second scanning head and adjust for identical amplitude and phasing.

Important:

The ratio tacho signal to superposed ripple voltage should reach at least 20 db (10:1).

2. Mount full reel and thread tape. Connect a digital frequency counter to test points TP1 (blk. + 0.0 V) and TP2 (wht. 800 Hz). Depress PLAY key. Adjust regulator L1 until the frequency counter displays a frequency of 800 Hz \pm 0.5 Hz.

For machines operating at 15/30 ips (38/76 cm) tape speed, the frequency should read 1600 Hz \pm 0.5 Hz.

3. The previously mentioned wow and flutter can be compensated with potentiometer R45 (TACHO HEAD). (Adjust with tape speed set at 7.5 ips).

Important:

Compensation at R45 is only measurable if all other components of the tape transport system produce a lesser amount of wow and flutter.

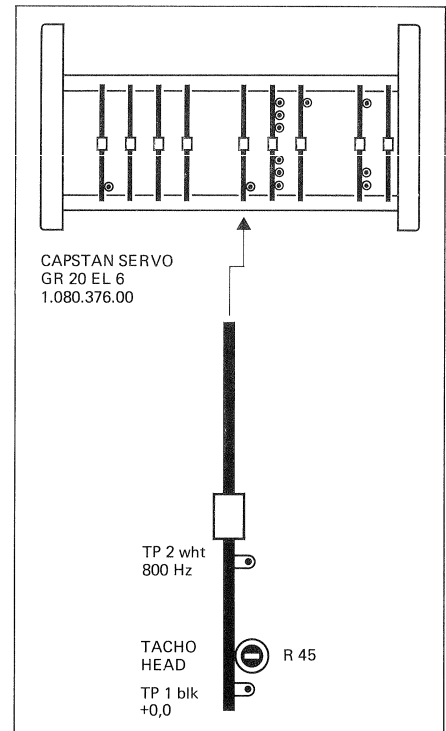

Fig. 4.19

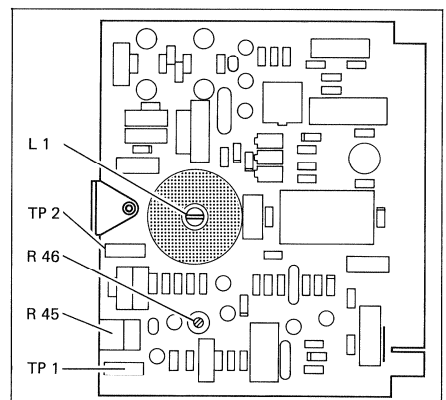

Fig. 4.20

4.3 PRÜFEN DER LAUFWERKLOGIK

4.3.1 Logische Ausgangs-Signale

Die Laufwerk-Logik verteilt sich auf die Steckkarten:

ATTENUATOR	EL 10
IC MEMORY AND COUNTER	EL 9 GR 20
IC DECODER AND DRIVERS	EL 8

und wird von den Steuerbefehlen der Drucktasten und den Signalen der Sensoren beeinflusst.

Eine Funktion ist somit durch entsprechende Steuerbefehle der Drucktasten und der Sensor-Signale gegeben.

Exakt ausgedrückt heisst dies: Jede Kombination von Steuerbefehlen und Sensor-Signalen hat zusammen mit dem vorausgegangenen Zustand eine bestimmte Signal-Kombination an den Ausgängen des IC-Decoders zur Folge.

Die Kombination der Ausgangssignale löst die entsprechenden Arbeitsfunktionen der Elektromechanischen Elemente aus.

Eingangs-Signale und Ausgangs-Signale sind demzufolge logisch verknüpft. Diese Tatsache erleichtert die Prüfung und Fehlersuche beträchtlich, denn es ist nicht erforderlich die logischen Schaltungen zu verstehen. Es genügt zu wissen, dass ein bestimmter Befehl eine bestimmte Reaktion in Form eines Ablaufes logischer Signale erzeugt.

Dieser Zusammenhang lässt sich in Tabellenform festhalten. Eine solche Tabelle enthält die Ausgangs-Signale der Steckkarten:

ATTENUATOR
MEMORY
IC DECODER

mit den entsprechenden Bezeichnungen der Anschlusspunkte (TP) sowie der Signal-Namen (senkrecht gedruckt). Weiter sind auch die Signal-Namen der Sensoren enthalten, deren Zuordnung auf alle drei Steckkarten entfällt.

In den senkrechten Kolonnen sind die logischen Zustände der Signale aufgezeichnet, zur besseren Unterscheidung sind die aktivierten Lämpchen und Magnete mit Sternchen (*) angegeben. Ebenso sind nur die logischen Zustände angegeben, die für die entsprechende Funktion von Bedeutung sind.

4.3 CHECKING OF TAPE TRANSPORT LOGIC

4.3.1 Logical output signals

The tape transport logic is contained on the following PCBs:

ATTENUATOR	EL 10
IC MEMORY AND COUNTER	EL 9 GR 20
IC DECODER AND DRIVERS	EL 8

and their function is governed by the control signals originating from the operating keys and sensors.

A tape function, therefore, is controlled by the corresponding signals from the command keys and sensors.

To state it more precisely: each combination of control signals and sensor signals, together with the status, results in a certain signal combination at the output of the IC decoder.

This combination of output signals causes a corresponding action by the electromechanical elements.

Therefore, input and output signals are logically linked. This fact facilitates tracing of errors since it is not necessary to comprehend the layout of the logic circuits. It suffices to know that a given command will generate specific reactions in form of a sequence of logical signals.

The interrelationship can be presented in tabular form. Such a table contains the output signals of the PCBs:

ATTENUATOR
MEMORY
IC DECODER

with the corresponding labels of the transfer points (TP) and the signal names (listed vertically). In addition, the signal names of the sensors, whose functions are spread across all 3 PCBs are also included.

The vertical columns show the logical signal states. The activated indicator lights and magnets are identified with (*). Only the logical states relevant to the corresponding function are indicated.

It should be remembered that the logic is generally accessed with a logical "L" (except fader start, YBI-FAD = logical "H"). The signal for forward tape motion is YBI-DIR = "H".

Es sei daran erinnert, dass die Logik-Ansteuerung normalerweise mit logisch "L" erfolgt (Ausnahme Reglerstart, YBI-FAD logisch "H"). Für Bandbewegung vorwärts ist das entsprechende Signal YBI-DIR = "H".

Für bewegtes Band ist das entsprechende Signal Q-MOVE oder YBI-MOVE = "H". Logisch "L" am Ausgang der Treiberstufen des IC-Decoders bedeutet Aktivierung des angeschlossenen Elementes.

Die Testpunkte (TP) 3, 6 und 11 liegen direkt an den Basen der Treiberstufen, so dass diese ein inverses Signal gegenüber dem entsprechenden Ausgang anzeigen. Diese TP-Nummern sind deshalb in der Tabelle mit dem Negationszeichen (Querbalken über der Ziffer) gekennzeichnet.

(Beispiel: ist K-CUT am Anschluss 8B des IC-Decoders = "L", so ist der entsprechende TP = "H".)

Die waagrechten Zeilen enthalten die notwendigen logischen Zustände einer Funktion. Diese stellen von Zeile zu Zeile einen Funktionsablauf dar.

4.3.2

Logical Output Signals Nr. 1

siehe Seite 4/18

Die Tabelle LOGICAL OUTPUT SIGNALS Nr. 1 enthält einen gewöhnlichen Funktionsablauf, der mit dem Einschalten beginnt (Zeile 1) und mit dem Auflegen des Bandes weiterfährt (Zeile 2).

Die Zeile 3 zeigt den Zustand der Signale im Moment bevor die Taste FORWARD (schnelles Vorspulen) gedrückt wird.

Die nächste Zeile (PRESS FORWARD, Zeitzustand 1) zeigt die Signale bei gedrückter Taste. Diese Taste bleibt nun gedrückt (bis RELEASE FORWARD).

Die nächste Zeile zeigt die Signal-Zustände sobald sich das Band bewegt (MOVE SENSOR ON), YBI-MOVE wird "H".

Die Zeile RELEASE FORWARD (Taste loslassen) zeigt, dass der Zustand der Signale nicht ändert (ausser Aktivierungssignal YPS-FORW), da der Steuerbefehl gespeichert ist und sich das Band in Bewegung befindet.

In diese feinen Schritte aufgeschlüsselt, gibt die Tabelle weitgehenden Aufschluss über die Abläufe beim Betätigen einer Taste, beim Start (MOVE SENSOR ON), beim Anhalten des Bandes (MOVE SENSOR OFF) oder beim Richtungswechsel des Bandes.

For moved tape the corresponding signal for Q-MOVE or YBI-MOVE = "H". A logical "L" at the output of the driver stage to the IC decoder calls for activation of the element connected. Testpoints (TP) 3, 6, and 11 are located directly at the base of the driver stages. For this reason, their signal is inverse to the one of the corresponding output. These TP numbers, therefore, are identified with the negation sign (crossbar above digit). (Example: if K-CUT at connection point 8B of the IC decoder is = "L", the corresponding TP = "H").

The horizontal rows contain the necessary logical states of a function. From row to row we obtain a complete sequence of operations.

4.3.2

Logical output signals No 1

see page 4/18

The table LOGICAL OUTPUT SIGNALS No 1 represents a normal sequence of operation starting with power ON (row 1) and continuing with the treading of tape (row 2).

Row 3 shows the status of the signals immediately before the FAST FORWARD key is depressed.

The next row (DEPRESS FORWARD, time status 1) shows the signals with depressed key. The key remains depressed until RELEASE FORWARD occurs.

The next row shows the signal states occurring when the tape begins to move (MOVE SENSOR ON) and YBI-MOVE changes to "H".

The row RELEASE FORWARD (key released) shows that no change in signal occurs (except for activation signals YPS-FORW), because the command is stored and the tape is still in motion. When breaking down an operation into such individual steps, the table provides far-reaching information on the processes to be performed when a key is depressed, when starting the tape (MOVE SENSOR ON), when stopping the tape (MOVE SENSOR OFF) or when changing the running direction.

4.3.3**Logical Output Signals Nr. 2**

siehe Seite 4/19

Diese Tabelle zeigt, dass bei Regler-Start (FADER) die anderen Funktionen gesperrt sind (z.B. REWIND).

4.3.3**Logical output signals No 2**

see page 4/19

This table shows that other functions (such as REWIND) are inhibited when activating fader start (FADER).

4.3.4**Logical Output Signals Nr. 3**

siehe Seite 4/20

Diese Tabelle zeigt die Simulierung des Bewegungs-Signals bei Auftreten eines Lämpchen-defektes des Bewegungs-Sensors.

Der Defekt wird durch MOVE BULB "OFF" gekennzeichnet. Das Signal YBI-MOVE bleibt auch nach dem Defekt bestehen ("H"), die momentane Funktion bleibt erhalten. Sobald das Band hingegen gestoppt wird (PRESS STOP), kann die Funktion PLAY nicht mehr aktiviert werden. Die Speicherstellen YBI-FF1 bis 4 nehmen wohl das kodierte Wiedergabe-Signal an (HHHL), der Befehl wird jedoch in der Freigabestufe des IC-Decoders blockiert, so dass lediglich zur Taste STOP noch die Taste PLAY (B-REPR) aufleuchtet, die weiteren Elemente werden nicht aktiviert.

Die Umspulfunktionen hingegen laufen normal ab.

4.3.4**Logical output signals No 3**

see page 4/20

This table shows the simulation of the tape motion signal in case of a malfunctioning bulb in the tape motion sensor.

The defect is signalled by MOVE BULB "OFF". The signal YBI-MOVE remains available even after the defect occurs ("H"). The function in operation continues unchanged. However, as soon as the tape is stopped (depress STOP) the PLAY function can no longer be activated. The memory locations YBI-FF1 to 4 will accept the coded playback signal (HHHL), the instruction will however be blocked in the enabling stage of the IC decoder, so that the PLAY key will light up (B-REPR) together with the STOP key, however no further action will take place. The winding functions will continue to be operable in a normal manner.

4.3.5.**Logical Output Signals Nr. 4**

siehe Seite 4/21

In dieser Tabelle ist der Ausfall eines Richtungs-Sensor-Lämpchens angenommen.

Sobald DIR. BULB "OFF" eintritt, bleibt YBI-DIR im bisherigen Zustand (z.B. "H"). "hängen"; K-DIR und K-BRAKE sind blockiert; es ist keine elektrische Bremsung der Wickel-motoren mehr möglich.

Mit rein mechanischer Bremsung sind wohl die Stoppzeiten länger, die restlichen Funktionen bleiben jedoch völlig erhalten.

4.3.5**Logical output signals No 4**

see page 4/21

In the representation of this table it is assumed that a tape direction sensor bulb has failed. As soon as DIR. BULB "OFF" occurs, YBI-DIR remains fixed in its current status (e.g. "H"). K-DIR and K-BRAKE are blocked; electrical braking of the spooling motor is no longer possible.

When braking is reduced to mechanical action, the braking time becomes longer. The other functions, however, remain completely unaffected.

4.4 ZERO LOCATOR 1.080.395

Der ZERO LOCATOR hat die Aufgabe, auf einen Tastenbefehl das Band auf kürzestem Weg zum Zähler-Nullpunkt zurückzuführen. Die Schaltung bezieht Informationen aus der Laufwerksteuerung, nämlich Angaben über Grösse und Vorzeichen des augenblicklichen Zählerstandes sowie über die gewählte und momentane Bandgeschwindigkeit.

Nur die 7-Segment-Zähler 1.228.825 (A81, A80/RC, A800) und 1.228.830 (A80/R, A80/VU, A80 MCH) können verwendet werden. Die Brückenstecker auf den Zähler-Dekoder-Prints 1.228.811 bzw. 1.228.821 müssen auf Negativ-Anzeige gesteckt werden (mathematische Darstellung von Negativzeiten). Diese Zähler-Baugruppen enthalten bereits die zur Auslösung des Suchlaufes notwendige Taste LOC sowie eine Kontrolllampe.

Durch Betätigung der Stopp-Taste kann der Suchlauf jederzeit abgebrochen werden. Ein Bandriss führt ebenfalls zur Beendigung des Suchlaufes.

Achtung:

Während des Suchlaufes darf keine neue Wickelfunktion eingegeben werden, da sonst das System den Zielpunkt nicht mehr findet.

4.4.1 Signalverarbeitung

Der Suchlauf-Flip-Flop (IC 1) überwacht die Funktion des Locators. Diese Stufe wird durch das Signal S-ZLOCAT gesetzt und bleibt in diesem Zustand bis der Suchlauf beendet ist (ZERO-OUT genügend lange positiv) oder die Stopp-Lampe durch ein Signal einschaltet, welches nicht in der Locator-Schaltung erzeugt wird. Dieser Fall tritt bei Bandriss oder anderweitigem Abbruch des Suchlaufes auf.

Der Suchlauf-Flip-Flop gibt die Durchschaltung der Befehlssignale frei und löst gleichzeitig einen Wickelbefehl aus. Das Vorzeichen der Zählerdifferenz bestimmt die Bewegungsrichtung des Bandes.

Die Zählerstandsignale werden in einem Digital-Analog-Wandler in ein Gleichspannungssignal umgesetzt. Nur die beiden letzten Ziffern (Einer und Zehner der Sekunden) werden quantitativ untersucht. Alle anderen Ziffern (je 2 Stellen Minuten und Stunden) tragen die Wertigkeit "Minuten". Bei Zählerständen von grösser als 59 Sekunden ist der Wandler übersteuert.

4.4 ZERO LOCATOR 1.080.395

The purpose of the ZERO LOCATOR is to return to the counter zero position by the shortest route in response to a push-button command. The circuit obtains its information from the tape transport control in the form of data on the value and sign of the actual counter reading, and on the selected and instantaneous tape speed.

Only the 7-segment counters 1.228.825 (A81, A80/RC, A800) and 1.228.830 (A80/R, A80/VU, A80 MCH) can be used. The jumper connector on the counter decoder boards 1.228.811 or 1.228.821 must be set to negative indication (mathematical presentation of negative times). These counter assemblies already contain the button LOC needed to start the search, and also a control lamp.

The search can be interrupted at any time by pressing the stop-button. Breakage of the tape also terminates the search.

Warning:

A new winding mode must not be selected during the search, otherwise the system will not find the desired point.

4.4.1 Signal processing

Operation of the locator is monitored by the search flipflop (IC 1). This stage is set by the signal S-ZLOCAT and remains in this state until the search is ended (ZERO-OUT positive for long enough), or the stop lamp is switched on by a signal not produced in the locator circuit. This happens if the tape breaks or the search is interrupted for some other reason.

The search flipflop allows the command signals to pass, and at the same time triggers a winding mode command. Which direction the tape moves in depends on the sign of the counter difference. The counter-reading signals are converted in a digital-to-analogue converter into a DC voltage signal. Only the last two digits (units and tens of seconds) are examined quantitatively. All other digits (2 each for minutes and hours) are considered as "minutes". The converter is overdriven at counter readings greater than 59 seconds.

Das analoge Zählerstandsignal steht am positiven Eingang 12 des Komparators IC 5 zur Verfügung. Gleichzeitig wird mit Hilfe des Timers IC 6 ein der Wickelgeschwindigkeit proportionales Signal gebildet, welches über ein Einstellpotentiometer dem subtrahierenden Eingang 13 des IC 5 angelegt wird. Das System schaltet auf Stopp, wenn das Zählerstandsignal kleiner als das Geschwindigkeitssignal wird. Wenn das Geschwindigkeitssignal wieder kleiner als das Differenzsignal ist, schaltet das System wieder auf die richtige Wickelfunktion zurück.

Das System folgt einer linearen Einlaufkennlinie. Die Steilheit der Auslösekurve ist mit Hilfe des Potentiometers R1 einstellbar. Gleichzeitig wird durch die Geschwindigkeitswahl die Kurve steiler gelegt. Die optimale Einstellung ist dann erreicht, wenn das System mit einer Bremsung den Nullpunkt findet. Als Kompromiss soll jedoch das System derart eingestellt werden, dass die Motoren eher zu früh zum Stillstand kommen um ein Überfahren des Nullpunktes zu verhindern.

Mit Hilfe von S1 kann das System für 15/30 ips-Laufwerke angepasst werden.

The analogue counter-reading signal is available at the positive input 12 of the comparator IC 5. At the same time, a signal proportional to the winding speed is generated with the aid of timer IC 6 and fed via an adjusting potentiometer to the subtracting input 13 of IC 5. The system switches to stop when the counter-reading signal becomes smaller than the speed signal. When the speed signal is again smaller than the difference signal, the system switches back once more to the correct winding mode. The system follows a linear approach characteristic.

The slope of the release curve can be varied with the aid of potentiometer R1. The choice of speed also makes the curve steeper. The optimum setting is obtained when the system arrives at a reading of zero with the brake applied. As a compromise, however, the system should be set so that the motors come to a standstill a little early, so as to avoid overshooting the zero point. The system can be adapted to 15/30 ips decks with the aid of S1.

4.4.2

Signallegende

Zählerstandsignale, P–MOS, –12 V active high

BCD2**3

Zählerstand, BCD codiert, Wertigkeit $2^3 = 8$

BCD2**2

Zählerstand, BCD codiert, Wertigkeit $2^2 = 4$

BCD2**1

Zählerstand, BCD codiert, Wertigkeit $2^1 = 2$

BCD2**0

Zählerstand, BCD codiert, Wertigkeit $2^0 = 1$

DIG10**1

Aktivierungssignal der 10 Sekundenstelle

DIG10**0

Aktivierungssignal der 1 Sekundenstelle

ZERO–OUT

Anzeigesignal, Zählerstand Null

Y2–SIGN

TTL, positiv bei negativem Zählerstand

Zustandssignale des Laufwerkes, 24 V, active low

YPS–MOVE

Impulsförmiges Bandbewegungssignal, 16 bzw. 18 Impulse pro 19 cm Bandbewegung

Y–HIGH

Geschwindigkeitswahl-Signal, 0 V bei der hohen Bandgeschwindigkeit

B–STOP

Signal der Stopp-Lampe, active low

Steuersignale für Laufwerk oder Locator

S–STOP

LOW, wenn Stopp-Befehl

S–FORW

LOW, wenn Vorspul-Befehl

S–REW

LOW, wenn Rückspul-Befehl

S–ZLOCAT

Auslösung des Suchlaufes

D–ZLOCAT

Signal der Suchlauf-Anzeige (LED ab 5,8 V)

B–ZLOCAT

Signal der Suchlauf-Anzeige (Glühlampe ab 24 V)

4.4.2

Key to signals

Counter-reading signals, P–MOS, +12 V active high

BCD2**3

Counter reading, BCD-coded, weight $2^3 = 8$

BCD2**2

Counter reading, BCD-coded, weight $2^2 = 4$

BCD2**1

Counter reading, BCD-coded, weight $2^1 = 2$

BCD2**0

Counter reading, BCD-coded, weight $2^0 = 1$

DIG10**1

Activating signal for 10-seconds digit

DIG10**0

Activating signal for unit seconds digit

ZERO–OUT

Display signal, counter reading zero

Y2–SIGN

TTL, positive with negative counter reading

Tape transport status signals, 24 V, active low

YPS–MOVE

Pulsed tape motion signal, 16 or 18 pulses per 7.5" of tape movement

Y–HIGH

Speed selector signal, 0 V at high tape speed

B–STOP

Stop lamp signal, active low

Control signals for tape transport or locator

S–STOP

LOW if command Stop

S–FORW

LOW if command Forward

S–REW

LOW if command Rewind

S–ZLOCAT

Initiates search

D–ZLOCAT

Search indicator signal (LED from 5.8 V)

B–ZLOCAT

Search indicator signal (filament lamp from 24 V)

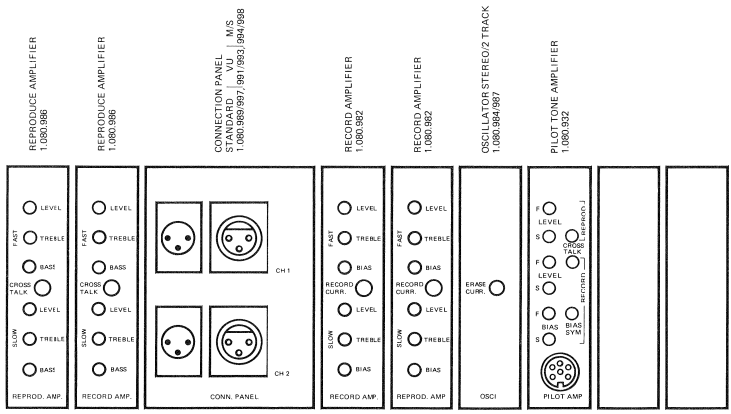
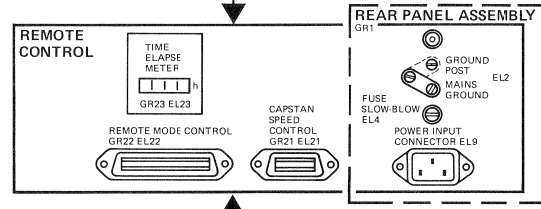
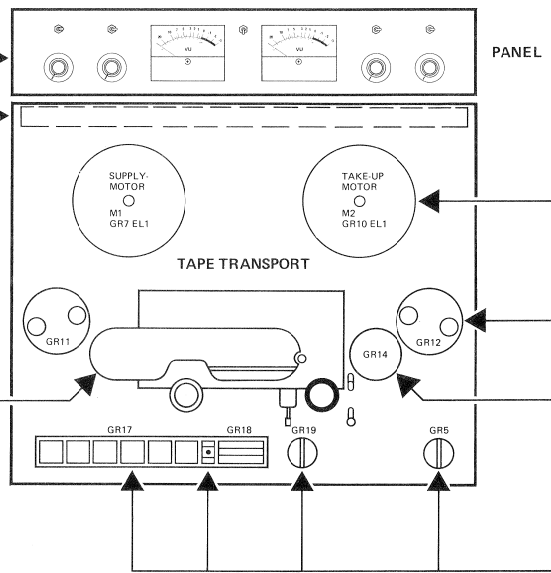
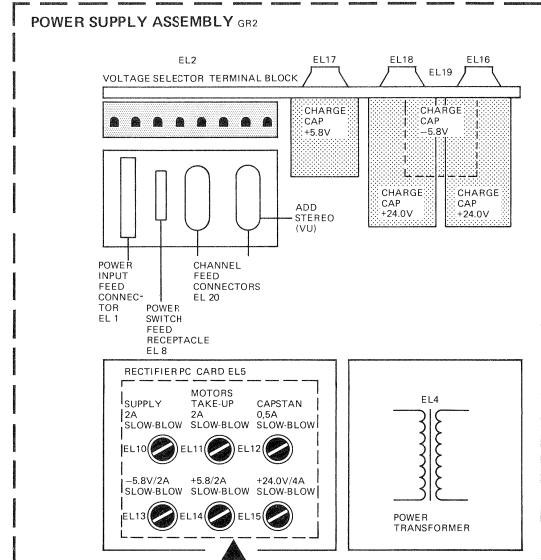
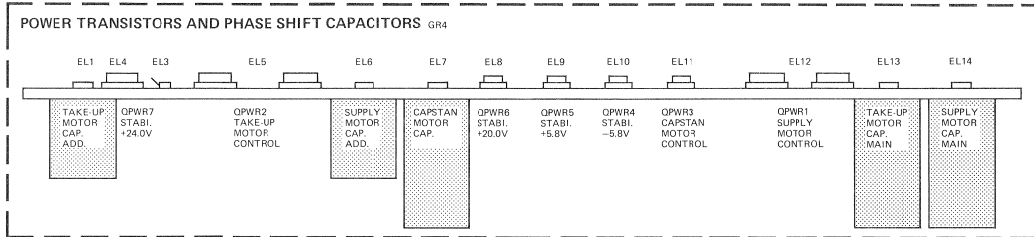

- 01 REAR PANEL ASSEMBLY
- 02 POWER SUPPLY ASSEMBLY
- *03 EXTENSION CABLE, PWR SUPPLY-MAINS SWITCH
- 04 PWR TRANSISTORS + PHASE SHIFT CAPACITORS
- 05 TAPE SPEED + POWER SWITCH ASSEMBLY
- *06 CONTROL UNIT, SPEED SELECTOR CABLE PLUG
- 07 CONTROL UNIT, SUPPLY MOTOR, CABLE PLUG
- *08 FEED TO BRAKE LIFT SOLENOID LEFT
- 09 FEED TO BRAKE LIFT SOLENOID RIGHT
- 08 FEED TO BRAKE LIFT SOLENOID LEFT
- 09 FEED TO BRAKE LIFT SOLENOID RIGHT
- 10 CONTROL UNIT, TAKE-UP MOTOR, CABLE PLUG
- 11 FEED TO TAPE TENSION CONTROL LEFT
- 12 FEED TO TAPE TENSION CONTROL RIGHT
- *13 FEED TO OPTICAL TAPE SENSOR
- 14 FEED TO TAPE MOVE + DIRECTION SENSOR
- *15 FEED TO TAPE TENSION CONTROL LEFT
- *16 FEED TO PRESSURE ROLLER ASSEMBLY
- *16 CONTROL UNIT, CAPSTAN MOTOR, CABLE PLUG
- 17 FEED TO LOCAL COMMAND SWITCHES
- 18 FEED TO LOCAL TAPE TIMER
- 19 CONTROL UNIT, CUTTER CONTROL, CABLE PLUG
- 20 CONTROL UNIT, CARD CHASSIS
- 21 CAPSTAN SPEED CONTROL CONNECTOR, REMOTE
- 22 MODE CONTROL CONNECTOR, REMOTE
- 23 TIME ELAPSE METER, CABLE PLUG

*NOT SHOWN IN THIS DIAGRAM

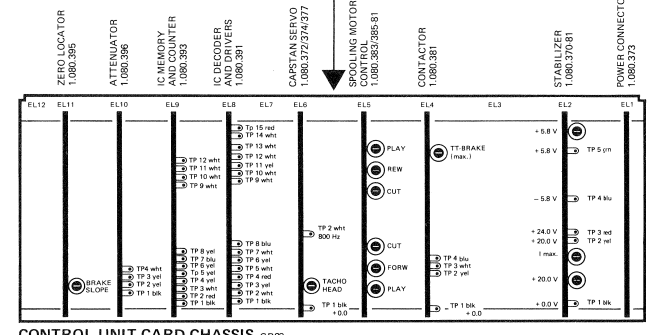

CONTROL UNIT CARD CHASSIS GR20

GR	DESCRIPTION OF GROUP	PART # OF GR
01	REAR PANEL ASSEMBLY	1.080.730.00
02	POWER SUPPLY ASSEMBLY	1.080.320.00
03	EXTENSION CABLE, PWR SUPPLY-MAINS SWITCH	1.080.288.00
04	PWR TRANSISTORS & PHASE SHIFT CAPACITORS	1.080.415.00
05	TAPE SPEED & POWER SWITCH ASSEMBLY	1.080.283.00
06	CONTROL UNIT, SPEED SELECTOR CABLE PLUG	1.080.420.00
07	CONTROL UNIT, SUPPLY MOTOR, CABLE PLUG	1.080.420.00
08	FEED TO BRAKE LIFT SOLENOID LEFT	1.080.420.00
09	FEED TO BRAKE LIFT SOLENOID RIGHT	1.080.420.00
10	CONTROL UNIT, TAKE-UP MOTOR, CABLE PLUG	1.080.420.00
11	FEED TO TAPE TENSION CONTROL LEFT	1.080.420.00
12	FEED TO TAPE TENSION CONTROL RIGHT	1.080.420.00
13	FEED TO OPTICAL TAPE SENSOR	1.080.420.00
14	FEED TO TAPE MOVE & DIRECTION SENSOR	1.080.420.00
15	FEED TO PRESSURE ROLLER ASSEMBLY	1.080.420.00
16	CONTROL UNIT, CAPSTAN MOTOR, CABLE PLUG	1.080.420.00
17	FEED TO LOCAL COMMAND SWITCHES	1.080.420.00
18	FEED TO LOCAL TAPE TIMER	1.080.420.00
19	CONTROL UNIT, CUTTER CONTROL, CABLE PLUG	1.080.420.00
20	CONTROL UNIT, CARD CHASSIS	1.080.351.00
21	CAPSTAN SPEED CONTROL CONNECTOR, REMOTE	1.080.425.00
22	MODE CONTROL CONNECTOR, REMOTE	1.080.426.00
23	TIME ELAPSE METER, CABLE PLUG	1.080.351.00

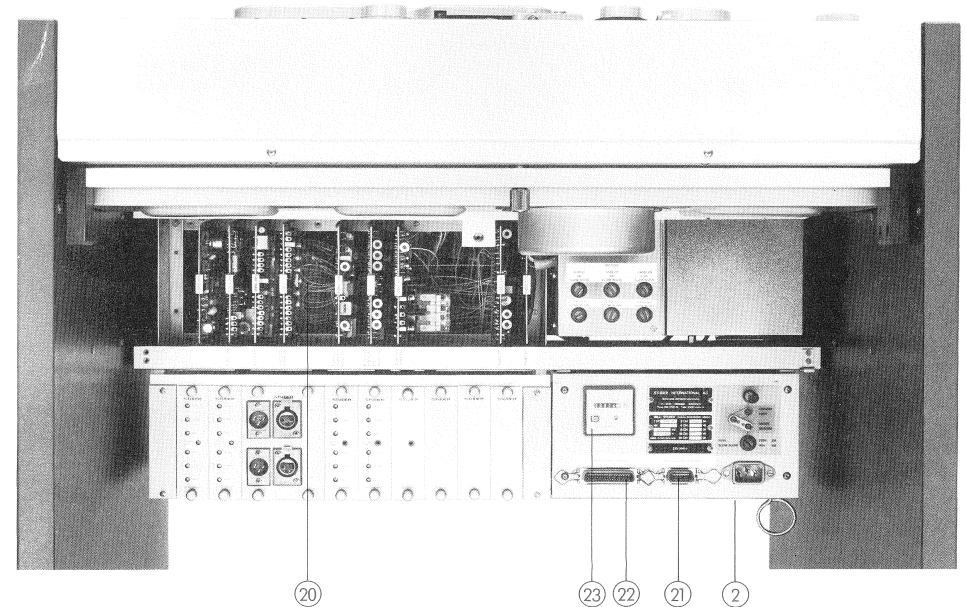
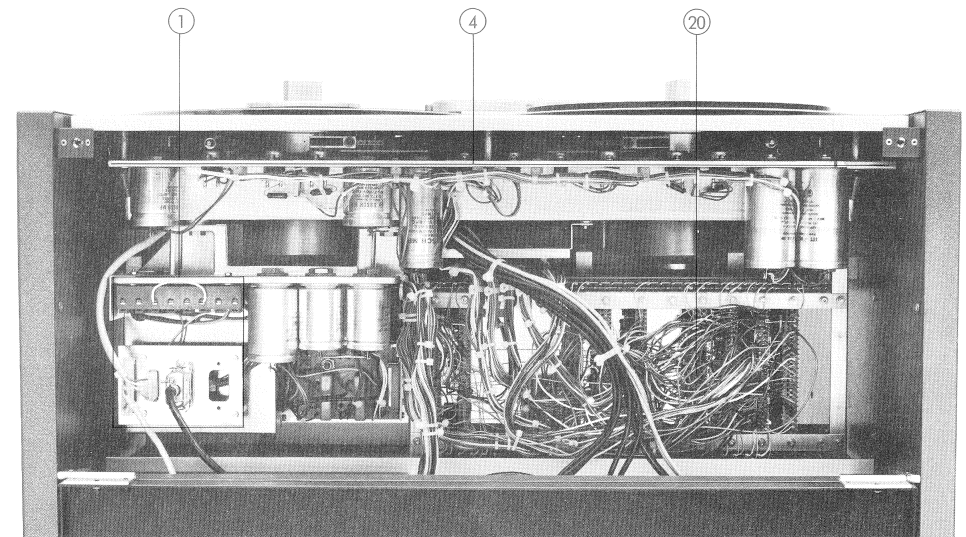

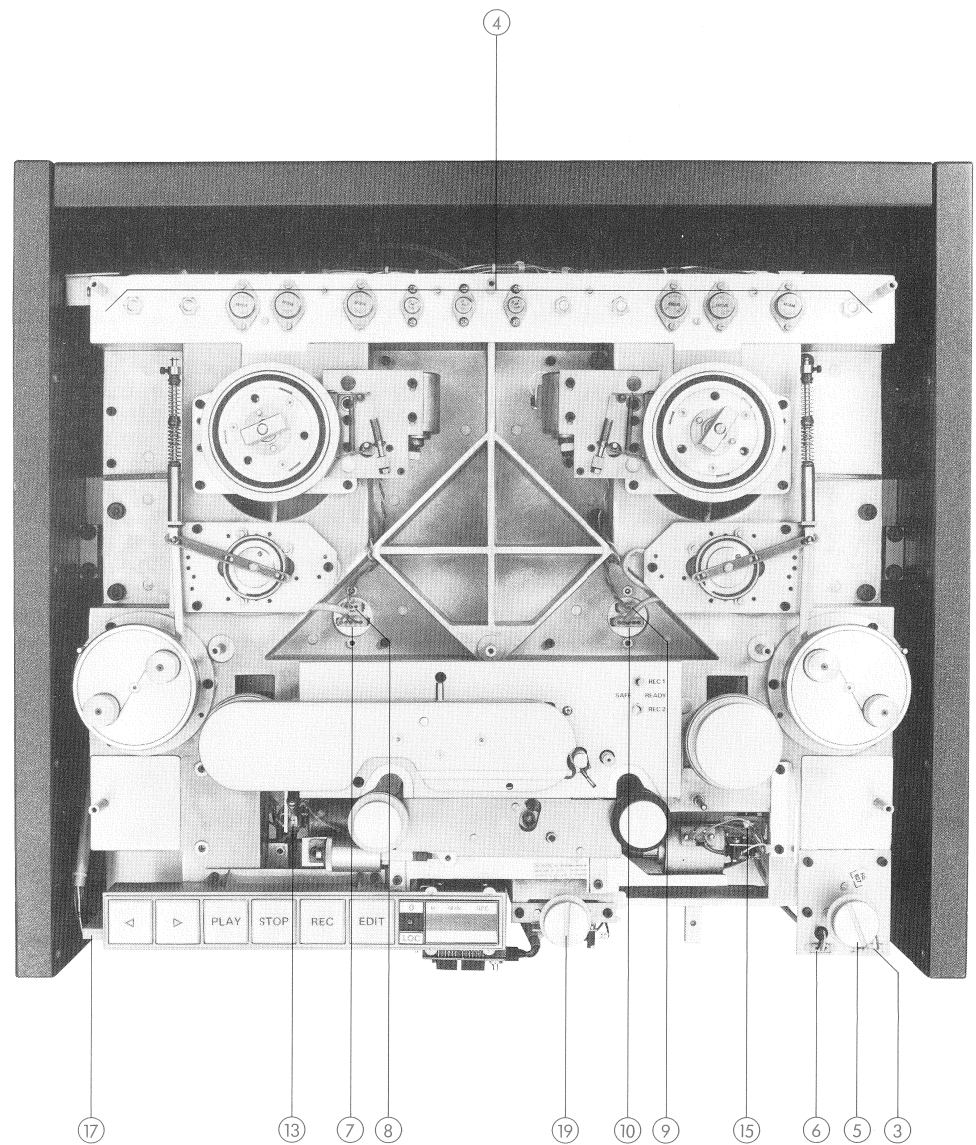
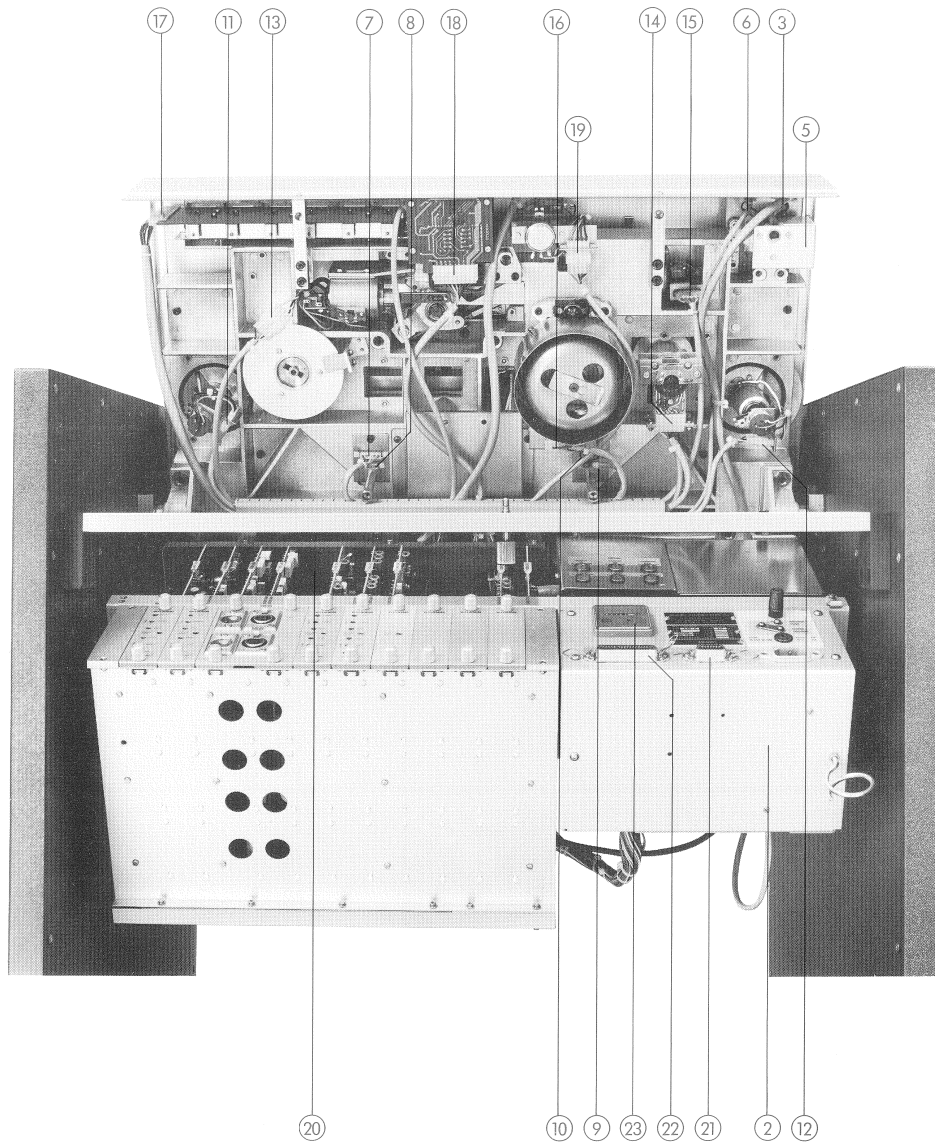

**4.5
GRUPPENÜBERSICHT****GRUPPE**

- ① Rückwand-Einheit
- ② Netzteil-Einheit
- ③ Verlängerungskabel vom Netzteil zum Netzschalter
- ④ Leistungstransistoren und Phasenschieber-Kondensatoren
- ⑤ Geschwindigkeits- und Netzschalter-Einheit
- ⑥ Steuer-Einheit, Geschwindigkeitsschalter, Kabelstecker
- ⑦ Steuer-Einheit, Wickelmotor (M1, links), Kabelstecker
- ⑧ Zuführung zu Bremslüft-Magnet, links
- ⑨ Zuführung zu Bremslüft-Magnet, rechts
- ⑩ Steuer-Einheit, Wickelmotor (M2, rechts), Kabelstecker
- ⑪ Zuführung zu Bandzugwaage, links
- ⑫ Zuführung zu Bandzugwaage, rechts
- ⑬ Zuführung zu optischem Bandendschalter
- ⑭ Zuführung zu Bandbewegungs- und Richtungssensor
- ⑮ Zuführung zu Andruckrollen-Einheit
- ⑯ Steuer-Einheit, Tonmotor, Kabelstecker
- ⑰ Zuführung zu Drucktastensatz
- ⑱ Zuführung zu Bandzähler
- ⑲ Steuer-Einheit, Schneid-Einheit, Kabelstecker
- ⑳ Steuer-Einheit, Steckkarten-Chassis
- ㉑ Stecker für Tonmotor-Geschwindigkeitssteuerung
- ㉒ Stecker für Laufwerk-Fernsteuerung
- ㉓ Betriebsstundenzähler, Kabelstecker

**4.5
SUMMARY OF EQUIPMENT MODULES****MODULE**

- ① Rear panel assembly
- ② Power supply assembly
- ③ Extension cable from power supply to mains switch
- ④ Power transistors and phase-shifting capacitors
- ⑤ Tape speed selector and power switch assembly
- ⑥ Control unit, speed selector cable plug
- ⑦ Control unit, spooling motor (M1 left-hand), cable plug
- ⑧ Supply for brake lifting magnet, left-hand
- ⑨ Supply for brake lifting magnet, right-hand
- ⑩ Control unit, spooling motor (M2, right-hand)
- ⑪ Supply for tape tension sensor, left-hand
- ⑫ Supply for tape tension sensor, right-hand
- ⑬ Supply for optical tape-end sensor
- ⑭ Supply for tape motion and direction sensor
- ⑮ Supply for pinch-roller unit
- ⑯ Control unit, capstan motor, cable plug
- ⑰ Supply for push button assembly
- ⑱ Supply for local tape counter
- ⑲ Control unit, cutting control, cable plug
- ⑳ Control unit, PCB card rack
- ㉑ Capstan motor control connector
- ㉒ Remote control connector for tape transport system
- ㉓ Time elapse meter, cable plug

4.6 VERDRAHTUNGS-LISTEN

Bei Geräten mit umfangreicher Elektronik sind Verdrahtungsschaltbilder unübersichtlich und geben Anlass zu Fehlinterpretationen. Deshalb wurde hier die zuverlässigere Methode mit Computer-Verdrahtungslisten gewählt. Diese informieren lückenlos über jede Verbindung innerhalb der Laufwerk-Elektronik.

Zur besseren Übersicht ist die ganze Laufwerk-Steuerung in Gruppen (GR) aufgeteilt. Die einzelnen Gruppen sind wiederum in Elemente (EL) und Punkte (PT) aufgeschlüsselt.

Zudem tragen sämtliche Signale Namen, die aus verschiedenen Abkürzungen kombiniert sind und die jeweilige Funktion erkennen lassen.

4.6.1 Gruppen

Die zentrale Steuereinheit (CONTROL UNIT), Gruppe 20 ist in WIRE-WRAP Technik lötfrei verdrahtet. Vom wire-wrap-Panel führen die Verbindungen zu den weiteren Gruppen des Laufwerkes. Kabel- und Kabelstecker (MOLEX oder AMP) tragen die entsprechende Gruppennummer.

4.6.2 Elemente, Punkte

Gruppen, die über mehrere Steckkarten oder andere Einheiten verfügen, sind in Elemente (EL) aufgeteilt.

Diese Elemente sind die Träger der Anschluss-Punkte (PT). Über die Art der Anschlüsse, siehe Abschnitt 4.8.

4.6.3 Drahtbeschriftungen

Die wichtigsten Anschlussdrähte der Verkabelung sind beschriftet. Diese Drahtenden tragen zwei Nummern, die das Element der jeweiligen Gruppe und den entsprechenden Anschluss-Punkt angeben.

Beispiel:
Phasenschieber-Kondensator des Tonmotors, GR 04, EL 07 Anschlussdraht grau. Dieser Draht trägt die Bezeichnung 7-2. Dies bedeutet, dass der graue Draht am Element 07, Anschluss 2 angelötet ist.

4.6 WIRING LIST

It is impractical to design wiring diagrams for equipment containing extensive electronic circuitry. The cluttered diagrams could lead to misinterpretations. We have, therefore, opted for the more reliable computer-generated wiring lists which give complete data on all the interconnections within the entire electronics.

The tape transport control system has been broken down into various assemblies or component groups (GR) to improve readability. The individual component groups in turn are coded as elements (EL) and points (PT).

In addition, all signals carry acronyms composed of various abbreviations so that their functions can easily be recognized.

4.6.1 Component groups

The CONTROL UNIT, group 20 is implemented in WIRE-WRAP technology and therefore does not feature soldered joints. The connections lead from the wire wrap panel to other groups of the tape transport system. Cables and cable plugs (MOLEX or AMP) are identified with the corresponding group number.

4.6.2 Elements, points

Groups comprising multiple circuit boards or other units are broken down into elements (EL).

These also contain the connecting points (PT). The types of connections are indicated in chap. 4.9.

4.6.3 Wire identification

The main connections of the wiring layout are labelled. Two numbers are affixed to the wire ends: the element number of the associated group and the appropriate connecting point.

Example:
Phase-shifting capacitor of the capstan motor GR 04, EL 07, connecting wire = grey. This wire is labelled with the number 7-2, indicating that the grey wire is soldered to element 07, connecting point 2.

**4.7
LOCATION PIN LIST**

Diese Liste ist nach Gruppen geordnet. Ist die Gruppennummer (siehe auch 4.5.1) oder die Gruppenbezeichnung bekannt, so können die weiteren Informationen aus dieser Liste bezogen werden.

Ist der Signal-Name bekannt, so ist die SIGNAL WIRE LIST, Abschnitt 4.7 zu benutzen.

Die Liste ist in der Reihenfolge der Gruppennummern (GR) von 1 bis 23 aufgeschlüsselt.

**4.7
LOCATION PIN LIST**

This list is sorted according to group number. If the group number (see 4.6.1) or the group name is known, further information can be extracted from this list.

If the signal name is known, the SIGNAL WIRE LIST is to be consulted (see chap. 4.8).

The list is arranged in sequence by group number, ranging from GR 2 to GR 23.

```
*****
79/08/31 * 16:05 * P A G E 4 *
*****
79/08/30
```

Gruppe _____ GR: 04 1.080.415.00
Group _____ PWR TRANSISTORS & PHASE SHIFT CAPACITORS

Element _____ EL: 07 CAPSTAN MOTOR CAPACITOR
Element _____

TYPE	PT	LV	SIG.NAME	COLOR	F	X	Y
L	01	1	T-M3	1			
L	02	1	C-M3-2	8			

Anschlussyp _____
Type of connection _____

Anschlusspunkt _____
Connection point _____

Signal Name _____
Signal name _____

Farbe _____
Color _____

Beispiel:
Unter 4.5.3 ist in der LOCATION PIN LIST, PAGE 4 zu finden (unterstrichene Zeile):

Gruppe GR 04
POWER TRANSISTORS
& PHASE SHIFT
CAPACITORS

Example:
In the LOCATION PIN LIST, Page 4, item 4.6.3 (underscored position) we find:

Group GR 04
POWER TRANSISTORS
& PHASE-SHIFT
CAPACITORS

CAPSTAN MOTOR CAPACITOR
Element: 07
Anschluss-Type: L (gelötet), siehe auch 4.8
Anschluss Punkt: 02
SIGNAL NAME: C-M3-2
Farbe: 8 (grau)

CAPSTAN MOTOR CAPACITOR
Element: 07
Type of connection: L (soldered), also see 4.9
Connection point: 02
Signal name: C-M3-2
Color: 8 (grey)

**4.8
SIGNAL WIRE LIST**

Diese Liste ist nach Signal-Namen geordnet. Ist der Signal-Name bekannt, so können die weiteren Informationen aus dieser Liste bezogen werden.

Ist nur die Gruppenbezeichnung oder die Gruppennummer bekannt, so ist die LOCATION PIN LIST, Abschnitt 4.6 zu benutzen.

Diese Liste ist in alphabetischer Reihenfolge der Signal-Namen aufgeschlüsselt (der alphabetischen Reihenfolge vorangestellt sind die Signal-Namen der Nullpunkte und der Speisespannungen).

Der Signal-Name ist in der ersten Spalte zu suchen. In dieser Spalte ist auch die Drahtfarbe angegeben. In der zweiten und dritten Spalte ist aufgeführt, an welchen Anschlusspunkten der entsprechenden Gruppen und Elemente das jeweilige Signal erscheint.

**4.8
SIGNAL WIRE LIST**

This list is arranged in sequence by signal name. Further data can be extracted from this list when the signal name is known.

The location pin list (chap. 4.7) is to be utilized when only the group number is known.

This list is in alphabetical signal name sequence (the signal names are preceded by the signal names of the zero ground and the supply voltages).

The signal name is given in the first column which also contains the color code of the wire. The second and third columns indicate the connection point of the corresponding group and element on which the signal becomes available.

```
*****
T * 79/08/31 * 16:05 * P A G E 18 *
*****
.005.00 79/08/30
```

SIG.NAME	COLOR	TYPE	GR	EL	PT	S	DESCRIPTION OF ELEMENT
Signal Name	C-M3-2	8	L	04	07	02	CAPSTAN MOTOR CAPACITOR
Signal name			M	16	01	03	CAPSTAN MOTOR ASSEMBLY
Farbe			WT	20	06	15B	# CAPSTAN SERVO PC CARD
Color							
Anschlusstyp							
Type of connection			Gruppe				Elementnummer
			Group				Element number

Beispiel:
Unter 4.5.3 (CAPSTAN MOTOR CAPACITOR) und unter 4.6 (der entsprechende Signal-Name C-M3-2) ist in der SIGNAL WIRE LIST, PAGE 17 zu finden:

Signal-Name: C-M3-2
Die Verbindungen mit diesem Signal führen vom:

CAPSTAN MOTOR CAPACITOR (GR 04, EL 07, PT 02) (Phasenschieber-Kondensator des Tonmotors) über den Gruppen-Knotenpunkt (=) auf der Steckkarte:

CAPSTAN SERVO PC CARD (GR 20, EL 06, PT 15B) (Printplatte Tonmotor-Regelung)

zum:
CAPSTAN MOTOR ASSY (GR 16, EL 01, PT 03) (Tonmotor)

Damit ist die Angabe über diese Verbindung vollständig.

Example:
Continuing the example of chap. 4.6.3 (CAPSTANMOTOR CAPACITOR) and 4.7 (corresponding signal name C-M3-2) we find on page 17 of the signal wire list:

Signal name: C-M3-2
The connections for this signal lead from:

CAPSTAN MOTOR CAPACITOR (GR 04, EL 07, PT 02) (phase-shift capacitor of the capstan motor) via the group junction (=) on the PCB:

CAPSTAN SERVO PC CARD (GR 20, EL 06, PT 15B) (printed circuit board for capstan control).

to:
CAPSTAN MOTOR ASSY (GR 16, EL 01, PT 03) (Capstan motor).

This completes the specifications for this particular connection.

4.9 VERDRAHTUNGS-TYPEN (Anschluss-Typen)

In der folgenden Aufstellung ist die Bedeutung der Abkürzungen ersichtlich.

Type	Bezeichnung	Ersatzteilnummer
F	MOLEX-Stecker, weiblich (female)	
	Steckerhülsen für dünne Litzen	54.02.0412
	Steckerhülsen für dicke Litzen	54.02.0413
H	Lötstift (solder hook)	
L	Lötfahne (solder lug)	
	MOLEX-Stecker, männlich (male)	
	Steckerstifte für dünne Litzen	54.02.0411
	Steckerstifte für dicke Litzen	54.02.0410
P	MOLEX-Printstecker, Steckerhülsen	54.06.4512
S	Schraub-Anschluss (screw terminal)	
T	TERMI-POINT Steckanschluss auf wire-wrap Stifte	
V	Rund-Steckhülse	54.02.0432
W	WIRE WRAP-Anschluss	
X	AMP-Stecker 0,5 x 3,8	54.02.0325
Y	AMP-Stecker 0,8 x 3,8 für dünne Litzen	54.02.0326
	für dicke Litzen	54.02.0327

4.9 WIRING METHODS (Connection types)

The following list gives an explanation of the various abbreviations used.

Type	Description	Part No
F	MOLEX connector, female	
	connector socket for thin braided wire	54.02.0412
	connector socket for heavy braided wire	54.02.0413
H	Solder hook	
L	Solder lug	
M	MOLEX plug (male)	
	connector pin for thin braided wires	54.02.0411
	connector pin for heavy braided wires	54.02.0410
P	MOLEX print connector	
	connector socket	54.06.4512
S	Screw terminal	
T	TERMI-POINT Terminal for wirewrap pins	
V	Round plug coupling	54.02.0432
W	Wire Wrap connection	
X	AMP plug 0.5 x 3.8	54.02.0325
Y	AMP plug 0.8 x 3.8 for thin braided wires	54.02.0326
	for heavy braided wires	54.02.0327

```

*****          *          *          *          *          *          *          *          *          *          *
*          *          *          *          *          *          *          *          *          *          *
*          *          *          *          *          *          *          *          *          *          *
*****          *          *          *          *          *          *          *          *          *          *
*****          *          *          *          *          *          *          *          *          *          *

```

***** P A G E 1 0 = 27

TITLE: PROFESSIONAL TAPE TRANSPORT DECK *** STUDER A-80/R *** 1.080.005.00 INDEX: 4 DATE OF ORIGIN: 79/08/30
 ***** DATE OF PROC.: 79/08/31

OPTIONS IN EFFECT: LOCLIS, SIGLIS, SIGSTA, WIRSTA, UNSPIN, CODKEY
 TOTAL GROUPS: 23
 TOTAL ELEMENTS: 75
 TOTAL PINS: 740
 TOTAL UNUSED PINS: 103
 MULTIPLE PINS: 0

SIGNALS: TOTAL: 214
 USED: 203
 UNUSED: 11
 DIAGNOSTICS GENERATED: N O N E
 GROUP NODE = *
 INTER GROUP NODE = #
 DIRECT WIRE TO # = <
 WIRING NOT COMPUTED = @

 * STUDER * L O C A T I O N P I N L I S T * 79/08/31 * 16:05 * P A G E 2 *

 PROFESSIONAL TAPE TRANSPORT DECK *** STUDER A-80/R *** 1.080.005.00 79/08/30

<p>GR: 01 1.080.730.00 REAR PANEL ASSEMBLY *****</p> <p>EL: 02 GROUND POST, EXTERNAL ----- TYPE PT LV SIG.NAME COLOR F X Y L 01 1 GROUND 4/5</p> <p>EL: 04 MAIN FJSE, TAPE DECK ----- TYPE PT LV SIG.NAME COLOR F X Y L 01 2 LINE2 7 L 02 2 F-LINE2 8</p> <p>EL: 05 MAINS FILTER ----- TYPE PT LV SIG.NAME COLOR F X Y Z 01 2 FL-LINE1 6 Z 01' 2 LINE1 6 Z 02 2 FL-LINE2 7 Z 02' 2 LINE2 7 K 03 2 GROUND 4/5</p> <p>EL: 08 POWER FEED CONNECTOR, MAINS ----- TYPE PT LV SIG.NAME COLOR F X Y F 01 1 LINE1 6 02 1 F 03 1 F-LINE2 8 04 1 F 05 1 GROUND 4/5 06 1 07 1 08 1</p> <p>EL: 09 POWER INPUT CONNECTOR ----- TYPE PT LV SIG.NAME COLOR F X Y L 01 2 FL-LINE1 6 L 02 2 FL-LINE2 7 L 03 2 GND MAIN 4/5</p>	<p>GR: 02 1.080.320.00 POWER SUPPLY ASSEMBLY *****</p> <p>EL: 01 POWER INPUT FEED CONNECTOR ----- TYPE PT LV SIG.NAME COLOR F X Y M 01 1 LINE1 6 02 1 M 03 1 F-LINE2 8 04 1 M 05 1 GROUND 4/5 06 1 07 1 08 1</p> <p>EL: 02 VOLTAGE SELECTOR TERMINAL BLOCK ----- TYPE PT LV SIG.NAME COLOR F X Y L 01 3* S-LINE1 2 L 02 2 T-5 1 L 03 2 T-6 4 L 04 2 T-7 6 L 05 2 T-2 0 L 06 2 T-3 8 L 07 3* T-4 3 L 08 2* S-LINE2 9</p> <p>EL: 03 SCREEN CHASSIS CONNECTION ----- TYPE PT LV SIG.NAME COLOR F X Y LS 01 1 SCREEN 0</p> <p>EL: 04 POWER TRANSFORMER ----- TYPE PT LV SIG.NAME COLOR F X Y L 01 1 S-LINE1 2 L 02 1 T-2 0 L 03 1 T-3 8 L 04 1 T-4 (5) L 05 1 T-5 1 L 06 1 T-6 4 L 07 1 T-7 6 L 08 1 S-LINE2 9 L 09 1 SCREEN 0 L 10 1 T-10 9 L 11 1 T-11 0 L 12 1 T-12 2 L 13 1 T-13 2 L 14 1 T-14 6 L 15 1 T-15 6 L 16 1 T-16 4 L 17 1 T-17 4 L 18 1 T-18 5 L 19 1 T-19 5</p>	<p>GR: 02 (CONTINUATION) POWER SUPPLY ASSEMBLY *****</p> <p>EL: 04 (CONTINUATION) ----- TYPE PT LV SIG.NAME COLOR F X Y L 20 1 T-20 8 L 21 1 T-21 6 L 22 1 T-22 8 L 23 1 T-23 8 L 24 1 T-24 0 L 25 1 T-25 0 L 26 1 T-26 1 L 27 1 T-27 1 L 28 1 T-28 2 L 29 1 T-29 2 L 30 1 T-30 9 L 31 1 T-31 9</p> <p>EL: 05 RECTIFIER & CONNECTOR PC CARD ----- TYPE PT LV SIG.NAME COLOR F X Y L 01 1 S-MONO 1 L 02 1 B-STOP 0 L 03 1 B-MONO 3 L 04 1 <-PRESS 0 L 05 1 Y-REC 5 L 06 1 >+24.0 2 L 07 1 S-HIGH 4 L 08 1 S-LOW 5 L 09 1 F-M2 9 L 10 1 F-M1 4 L 11 1 T-M1 1 L 12 1 > +0.0 0 L 13 1 > +0.0 0 L 14 1 > +0.0 0 L 15 1 F-M3 5 L 16 1 T-M2 6 L 17 1 > +31.0 9 L 18 1 -10.0 6 L 19 1 +10.0 8 L 20 1 > +5.8 5 L 21 1 T-M3 7 (1) Y 31 2* S-MONO-I 1 Y 32 2* S-HI 4 Y 33 2* K-STOP 0 Y 34 2* S-I3 3 Y 35 2* B-MONO-I 8 Y 36 2* Y-PRESS 0 Y 37 2* Y-RECJRD 9 Y 38 1 0-AC1 5 Y 39 1 0-AC2 7 Y 40 1 AC1 6 Y 41 1 AC2 7 Y 42 1 0-AC3 6 Y 43 1 0-AC4 7</p>
--	--	--

GR: 02 (CONTINUATION)
 POWER SUPPLY ASSEMBLY

EL: 05 (CONTINUATION)

TYPE	PT	LV	SIG. NAME	COLOR	F	X	Y
Y	44	1	AC3		6		
Y	45	1	AC4		7		
L	51	1	T-24		0		
L	52	1	T-25		0		
L	53	1	T-26		1		
L	54	1	T-27		1		
L	55	1	T-28		2		
L	56	1	T-29		2		
L	57	1	T-30		9		
L	58	1	T-31		9		
Y	59	1	+24.0(1)		2		
Y	60	1	+0.0(1)		0		
L	61	1	F-M1(0)		4		
L	62	1	T-17		4		
L	63	1	T-18		5		
L	64	1	T-20		8		
L	65	1	T-21		6		
L	66	1	F-M2(0)		5		
L	67	1	T-23		8		
L	68	1	F-M3(0)		8		
Y	69	1	M5-1		9		
Y	70	1	M5-2		9		
Y	71	1	+31.0(0)		9		
Y	72	1	+31.0(0)		9		
Y	73	1	+0.0(2)		0		
Y	74	1	+0.0(2)		0		
L	75	1	F(+24.0)		9		
L	76	1	T-11		0		
Y	77	1	T-17/18		1		
L	78	1	T-17/18		1		
Y	79	1	T-20/21		6		
L	80	1	T-20/21		6		
Y	81	1	+0.0(3)		0		
Y	82	1	+0.0(3)		0		
Y	83	1	-10.0(0)		6		
Y	84	1	-10.0(0)		6		
L	85	1	F(-5.8)		6		
L	86	1	T-15		6		
Y	91	1	+10.0(0)		8		
Y	92	1	+10.0(0)		8		
Y	93	1	+0.0(4)		0		
Y	94	1	+0.0(4)		0		
L	95	1	F(+5.8)		2		
L	96	1	T-13		2		

EL: 06 GROUND CHASSIS CONNECTION

TYPE	PT	LV	SIG. NAME	COLOR	F	X	Y
LS	01	1	GROUND		4/5		

GR: 02 (CONTINUATION)
 POWER SUPPLY ASSEMBLY

EL: 08 POWER SWITCH FEED, RECEPTACLE

TYPE	PT	LV	SIG. NAME	COLOR	F	X	Y
F	01	1	LINE1		6		
F	02	1	F-LINE2		8		
	03	1					
F	04	1	S-LINE2		9		
F	05	1	S-LINE1		2		

EL: 10 FUSE, SUPPLY MOTOR

TYPE	PT	LV	SIG. NAME	COLOR	F	X	Y
L	01	1	F-M1(0)		4		
L	02	1	T-16		4		

EL: 11 FUSE, TAKE-UP MOTOR

TYPE	PT	LV	SIG. NAME	COLOR	F	X	Y
L	01	1	F-M2(0)		5		
L	02	1	T-19		5		

EL: 12 FUSE, CAPSTAN

TYPE	PT	LV	SIG. NAME	COLOR	F	X	Y
L	01	1	F-M3(0)		8		
L	02	1	T-22		8		

EL: 13 FUSE, - 5.8 V

TYPE	PT	LV	SIG. NAME	COLOR	F	X	Y
L	01	1	F(-5.8)		6		
L	02	1	T-14		6		

EL: 14 FUSE, + 5.8 V

TYPE	PT	LV	SIG. NAME	COLOR	F	X	Y
L	01	1	F(+5.8)		2		
L	02	1	T-12		2		

EL: 15 FUSE, +24.0 V

TYPE	PT	LV	SIG. NAME	COLOR	F	X	Y
L	01	1	F(+24.0)		9		
L	02	1	T-10		0		

GR: 02 (CONTINUATION)
 POWER SUPPLY ASSEMBLY

EL: 16 CHARGE CAPACITOR, +24.0 V (1)

TYPE	PT	LV	SIG. NAME	COLOR	F	X	Y
L	01	3*	+31.0(0)		9		
L	02	3*	+0.0(2)		0		

EL: 17 CHARGE CAPACITOR, +24.0 V (2)

TYPE	PT	LV	SIG. NAME	COLOR	F	X	Y
L	01	1	+31.0(0)		9		
L	02	1	+0.0(2)		0		

EL: 18 CHARGE CAPACITOR, + 5.8 V

TYPE	PT	LV	SIG. NAME	COLOR	F	X	Y
L	01	2*	+10.0(0)		8		
L	02	2*	+0.0(4)		0		

EL: 19 CHARGE CAPACITOR, - 5.8 V

TYPE	PT	LV	SIG. NAME	COLOR	F	X	Y
L	01	2*	+0.0(3)		0		
L	02	2*	-10.0(0)		6		

EL: 20 CHANNEL FEED CONNECTOR

TYPE	PT	LV	SIG. NAME	COLOR	F	X	Y
L	01	1	S-MONO-I		1		
L	02	1	K-STOP		0		
L	03	1	S-L0		3		
L	04	1	S-HI		4		
L	05	1	+24.0(1)		2		
L	06	1	0-AC1		6		
L	07	1	0-AC2		7		
L	08	1	B-MONO-I		8		
L	09	1	Y-PRESS		0		
L	10	1					
L	11	1	Y-RECORD		9		
L	12	1					
L	13	1	AC1		6		
L	14	1	AC2		7		

EL: 21 FEED CONNECTOR, SYNCHRONIZ. OPT.

TYPE	PT	LV	SIG. NAME	COLOR	F	X	Y
L	01	1	S-MONO-I		1		
L	02	1	K-STOP		0		
L	03	1	S-L0		3		
L	04	1	S-HI		4		

GR: 02 (CONTINUATION)
 POWER SUPPLY ASSEMBLY

EL: 21 (CONTINUATION)

TYPE	PT	LV	SIG. NAME	COLOR	F	X	Y
L	05	1					
L	06	1	0-AC3		6		
L	07	1	0-AC4		7		
L	08	1	B-MONO-I		8		
L	09	1	Y-PRESS		0		
L	10	1					
L	11	1	Y-RECORD		9		
L	12	1					
L	13	1	AC3		6		
L	14	1	AC4		7		

GR: 03 1.080.288.00
 EXTENSION CABLE, PWR SUPPLY-MAINS SWITCH

EL: 01 EXTENSION CABLE, SUPPLY SIDE

TYPE	PT	LV	SIG. NAME	COLOR	F	X	Y
M	01	1	LINE1		6		
M	02	1	F-LINE2		8		
	03	1					
M	04	1	S-LINE2		9		
M	05	1	S-LINE1		2		

EL: 02 EXTENSION CABLE, SWITCH SIDE

TYPE	PT	LV	SIG. NAME	COLOR	F	X	Y
F	01	1	LINE1		6		
F	02	1	F-LINE2		8		
	03	1					
F	04	1	S-LINE2		9		
F	05	1	S-LINE1		2		

SR: 04 1.080.415.00
 PWR TRANSISTORS & PHASE SHIFT CAPACITORS

EL: 01 TAKE-UP MOTOR CAPACITOR, ADD.

TYPE	PT	LV	SIG. NAME	COLOR	F	X	Y
L	01	2	M2-2		7		
L	02	2	C-M2-2		8		

EL: 03 DC CHASSIS CONNECTION

TYPE	PT	LV	SIG. NAME	COLOR	F	X	Y
SL	01	1	+0.0		0		

EL: 04 +24.0 V STABILIZER TRANSISTOR

TYPE	PT	LV	SIG. NAME	COLOR	F	X	Y
H	01	1	+24.0		2		
H	02	1	QPWR7-2		1		
L	03	2D	+31.0		9		

EL: 05 TAKE-UP MOTOR TRANSISTOR PAIR

TYPE	PT	LV	SIG. NAME	COLOR	F	X	Y
L	01	2	QPWR2-1		1		
L	02	2	QPWR2-2		4		
L	03	2	QPWR2-3		9		

EL: 06 SUPPLY MOTOR CAPACITOR, ADD.

TYPE	PT	LV	SIG. NAME	COLOR	F	X	Y
L	01	2	M1-2		4		
L	02	2	C-M1-2		5		

EL: 07 CAPSTAN MOTOR CAPACITOR

TYPE	PT	LV	SIG. NAME	COLOR	F	X	Y
L	01	1	T-M3		1		
L	02	1	C-M3-2		8		

EL: 08 +20.0 V STABILIZER TRANSISTOR

TYPE	PT	LV	SIG. NAME	COLOR	F	X	Y
H	01	1	+20.0		3		
H	02	1	QPWR6-2		5		
L	03	1	+24.0		2		

GR: 04 (CONTINUATION)
 PWR TRANSISTORS & PHASE SHIFT CAPACITORS

EL: 09 + 5.8 V STABILIZER TRANSISTOR

 TYPE PT LV SIG.NAME COLOR F X Y

 H 01 1 QPWR5-1 5
 H 02 1 QPWR5-2 7
 L 03 1 QPWR5-3 9

EL: 10 - 5.8 V STABILIZER TRANSISTOR

 TYPE PT LV SIG.NAME COLOR F X Y

 H 01 1 QPWR4-1 1
 H 02 1 QPWR4-2 8
 L 03 1 QPWR4-3 6

EL: 11 CAPSTAN MOTOR CONTROL TRANSISTOR

 TYPE PT LV SIG.NAME COLOR F X Y

 H 01 1 QPWR3-1 4
 H 02 1 QPWR3-2 9
 L 03 1 QPWR3-3 7

EL: 12 SUPPLY MOTOR TRANSISTOR PAIR

 TYPE PT LV SIG.NAME COLOR F X Y

 L 01 2 QPWR1-1 2
 L 02 2 QPWR1-2 5
 L 03 2 QPWR1-3 8

EL: 13 TAKE-UP MOTOR CAPACITOR, MAIN

 TYPE PT LV SIG.NAME COLOR F X Y

 L 01 1 M2-2 7
 L 02 1 C-M2-2 8

EL: 14 SUPPLY MOTOR CAPACITOR, MAIN

 TYPE PT LV SIG.NAME COLOR F X Y

 L 01 1 M1-2 4
 L 02 1 C-M1-2 5

GR: 05 1.080.283.00
 TAPE SPEED & POWER SWITCH ASSEMBLY

EL: 01 POWER SWITCH FEED, JACK

 TYPE PT LV SIG.NAME COLOR F X Y

 M 01 1 LINE1 6
 M 02 1 F-LINE2 8
 03 1
 M 04 1 S-LINE2 9
 M 05 1 S-LINE1 2

EL: 02 POWER SWITCH, REAR

 TYPE PT LV SIG.NAME COLOR F X Y

 L 01 1 LINE1 6
 02 1
 L 03 1 S-LINE1 2

EL: 03 POWER SWITCH, FRONT

 TYPE PT LV SIG.NAME COLOR F X Y

 L 01 1 F-LINE2 8
 02 1
 L 03 1 S-LINE2 9

EL: 04 TAPE SPEED SELECTOR SWITCH

 TYPE PT LV SIG.NAME COLOR F X Y

 L 01 1 + 0.0 0
 L 02 1 S-LOW 5
 L 03 1 S-HIGH 4

EL: 05 SPEED SELECTOR FEED, JACK

 TYPE PT LV SIG.NAME COLOR F X Y

 F 01 1 + 0.0 0
 F 02 1 S-LOW 5
 F 03 1 S-HIGH 4

GR: 06 1.080.420.00
 CONTROL UNIT, SPEED SELECTOR CABLE PLUG

EL: 01 SPEED SELECTOR, CABLE PLUG

 TYPE PT LV SIG.NAME COLOR F X Y

 M 01 1@ + 0.0 0
 M 02 1 S-LOW 5
 M 03 1 S-HIGH 4

GR: 07 1.080.420.00
 CONTROL UNIT, SUPPLY MOTOR, CABLE PLUG

EL: 01 SUPPLY MOTOR (M1)

 TYPE PT LV SIG.NAME COLOR F X Y

 F 01 1 M1-1 1
 02 1
 F 03 1 M1-2 4
 04 1
 F 05 1 C-M1-2 5

GR: 08 1.080.420.00
 FEED TO BRAKE LIFT SOLENOID LEFT

EL: 01 BRAKE LIFT SOLENOID, LEFT

 TYPE PT LV SIG.NAME COLOR F X Y

 F 01 1@ +24.0 2
 F 02 1 K-LIFT 3
 03 1

GR: 09 1.080.420.00
 FEED TO BRAKE LIFT SOLENOID RIGHT

EL: 01 BRAKE LIFT SOLENOID, RIGHT

 TYPE PT LV SIG.NAME COLOR F X Y

 F 01 1@ +24.0 2
 F 02 1 K-LIFT 3
 03 1

GR: 10 1.080.420.00
 CONTROL UNIT, TAKE-UP MOTOR, CABLE PLUG

GR: 11 1.080.420.00
 FEED TO TAPE TENSION CONTROL LEFT

GR: 12 1.080.420.00
 FEED TO TAPE TENSION CONTROL RIGHT

EL: 01 TAKE-UP MOTOR (M2)

TYPE	PT	LV	SIG.NAME	COLOR	F	X	Y
F	01	1	M2-1	6			
F	02	1					
F	03	1	C-M2-2	8			
F	04	1					
F	05	1	M2-2	7			

EL: 01 TAPE TENSION CONTROL ASSY, LEFT

TYPE	PT	LV	SIG.NAME	COLOR	F	X	Y
M	01	1@	+20.0	3			
M	02	1	R-TT1	1			
M	03	1@	+0.0	0			
M	04	1	K-TT1/2	7			
M	05	1	S-TT	4			

EL: 01 TAPE TENSION CONTROL ASSY, RIGHT

TYPE	PT	LV	SIG.NAME	COLOR	F	X	Y
M	01	1@	+20.0	3			
M	02	1	R-TT2	2			
M	03	1@	+0.0	0			
M	04	1	K-TT	9			
M	05	1	K-TT1/2	7			

GR: 13 1.080.420.00
 FEED TO OPTICAL TAPE SENSOR

GR: 14 1.080.420.00
 FEED TO TAPE MOVE & DIRECTION SENSOR

GR: 15 1.080.420.00
 FEED TO PRESSURE ROLLER ASSEMBLY

EL: 01 OPTICAL TAPE END SENSOR

TYPE	PT	LV	SIG.NAME	COLOR	F	X	Y
M	01	1	+16.0	3			
M	02	1	+0-END	0			
M	03	1	RP-END	8			
M	04	1					
F	05	1	B-END	7			

EL: 01 TAPE MOVE SENSOR

TYPE	PT	LV	SIG.NAME	COLOR	F	X	Y
P	01	1@	+24.0	2			
P	02	1@	+5.8	5			
P	03	1	QP-MOVE	4			
P	04	1	+0-MOVE	0			
P	05	1	B-MOVE	6			
P	06	1	B-MOVE	6			

EL: 01 PRESSURE ROLLER ASSEMBLY

TYPE	PT	LV	SIG.NAME	COLOR	F	X	Y
F	01	1@	+24.0	2			
M	02	1	K-PRESS	8			
M	03	1	Y-ACCEL	6			
M	04	1	K-CJT	5			
M	05	1	S-TT	4			

EL: 02 TAPE DIRECTION SENSOR

TYPE	PT	LV	SIG.NAME	COLOR	F	X	Y
P	01	1@	+24.0	2			
P	02	1@	+5.8	5			
P	03	1	QP-DIR2	7			
P	04	1	+0-DIR1	0			
P	05	1	QP-DIR1	8			
P	06	1	B-DIR	9			

GR: 16 1.080.420.00
 CONTROL UNIT, CAPSTAN MOTOR, CABLE PLUG

GR: 17 1.080.420.00
 FEED TO LOCAL COMMAND SWITCHES

GR: 18 1.080.420.00
 FEED TO LOCAL TAPE TIMER

EL: 01 CAPSTAN MOTOR ASSEMBLY

TYPE	PT	LV	SIG-NAME	COLOR	F	X	Y
M	01	1	M3-1				6
M	02	1	T-M3				1
M	03	1	C-M3-2				8
M	04	1	0-YAC1				0
M	05	1	YAC1-M3				4
M	06	1					
M	07	1	0-YAC2				0
M	08	1	YAC2-M3				5

EL: 01 COMMAND SWITCHES, LOCAL

TYPE	PT	LV	SIG-NAME	COLOR	F	X	Y
P	01	1	B-INDIC				9
P	02	1	B-CUT				6
P	03	1	B-REC				5
P	04	10	B-STOP				1
P	05	1	B-REPR				4
P	06	1	B-FORW				3
P	07	1	B-REW				2
P	08	1	S-STOP				1
P	09	1	S-REW				2
P	10	1	S-FORW				3
P	11	1	S-REPR				4
P	12	1	S-REC				5
P	13	1	S-CUT				6
P	14	1	REM-IN				7
P	15	1	K-FAD-1				8

EL: 01 TIMER FEED PC-CARD PLUG

TYPE	PT	LV	SIG-NAME	COLOR	F	X	Y
P	01	10	-5.8				6
P	02	10	+0.0				0
P	03	1	K-RESET				1
P	04	10	+24.0				2
P	05	1	M4-1				3
P	06	1	M4-2				4
P	07	1	M4-3				5
P	08	1	M4-4				5
P	09	10	+5.8				5

EL: 02 TIMER FEED 11-POLE CIS PLUG

TYPE	PT	LV	SIG-NAME	COLOR	F	X	Y
V	01	1	Y2-SIGN				9
N	02	1	BCD2**0				0
N	03	1	BCD2**1				1
N	04	1	BCD2**2				2
V	05	1	BCD2**3				3
N	06	1	ZERO-OUT				8
N	07	1					
N	08	1					
N	09	1	DIG10**1				5
N	10	1	DIG10**0				5
N	11K	1	KEY				

EL: 03 TIMER FEED 3-POLE MUX P. JG

TYPE	PT	LV	SIG-NAME	COLOR	F	X	Y
M	01	1	D-ZLOCAT				4
M	02	1	S-ZLOCAT				7
F	03	10	+5.8				5

GR: 19 1.080.420.00
 CONTROL UNIT, CUTTER CONTROL, CABLE PLUG

GR: 20 1.080.351.00
 CONTROL UNIT, CARD CHASSIS

GR: 20 (CONTINUATION)
 CONTROL UNIT, CARD CHASSIS

EL: 01 CUTTER CONTROL ASSEMBLY

TYPE	PT	LV	SIG-NAME	COLOR	F	X	Y
M	01	1	R-CUT-1				5
M	02	10	+20.0				3
F	03	1	R-CUT-3				7
M	04	1	S-CUTAUT				1
M	05	1	+0-CUTAU				0

EL: 01 POWER CONNECTOR PC CARD

TYPE	PT	LV	SIG-NAME	COLOR	F	X	Y
WTL	01	30	+0.0				0
WTL	02	30	+0.0				0
WTL	03	3	S-HIGH				4
WTL	04	3	S-LOW				5
WTL	05	3	Y-REC				(5)
WTL	06	3	K-RESS				0
WTL	07	3	B-MONO				3
WTL	08	3	B-STOP				0
WTL	09	3	S-MONO				1
WTL	10	3					
WTL	11	3	T-M3				(7)
WTL	12	3	F-M3				(5)
WTL	13	3					
WTL	14	3	T-M2				(6)
WTL	15	3	F-M2				(9)
WTL	16	3	T-M1				(1)
WTL	17	3	F-M1				(4)
WTL	18	3					
WTL	19	3#	+31.0				9
WTL	20	3	+31.0				9
WTL	21	3	-10.0				(6)
WTL	22	3	+10.0				(8)
WTL	23	3	+24.0				(2)
WTL	24	3	+0.0				(0)
WTL	25	3	+5.8				(5)

EL: 02 (CONTINUATION)

TYPE	PT	LV	SIG-NAME	COLOR	F	X	Y
WT	22	3	QPWR5-3				9
WT	22K	0	<EY				
WT	23	3	QPWR5-2				7
WT	24	3	QPWR5-1				5
WT	25	3	+5.8				

EL: 02 +24/+20/+6/-6V STABIL. PC CARD

TYPE	PT	LV	SIG-NAME	COLOR	F	X	Y
WT	01	3	+0.0				
WT	02	3	+0.0				
WT	03	3	QPWR6-2				6
WT	04	3					
WT	05	3N	+31.0(N)				
WT	06	3	+31.0				
WT	07	3	QPWR7-2				1
WT	08	3	QPWR7-2				
WT	09	3	+20.0				3
WT	10	3	+20.0				
WT	11	3	+24.0				
WT	12	3	+24.0				2
WT	13	3	S-HIGH				4
WT	14	3	-5.8				(6)
WT	15	3	QPWR4-3				6
WT	16	3	QPWR4-2				8
WT	17	3	QPWR4-1				1
WT	18	3	-10.0				
WT	19	3	+0.0				
WT	20	3	+0.0				
WT	21	3	+10.0				

EL: 04 CONTACTOR PC CARD

TYPE	PT	LV	SIG-NAME	COLOR	F	X	Y
WT	01	3	+0.0				
WT	02	3	+0.0				
WT	03	3	+24.0				2
WT	04	3	+24.0				2
WT	05	3	YAN-M2				
WT	06	3#	M2-2				7
WT	06K	0	<EY				
WT	07	3	F-M2				
WT	08	3	M2-1				6
WT	+09	3#	C-M2-2				8
WT	10	3#	M1-2				4
WT	11	3	YAN-M1				
WT	12	3	M1-1				1
WT	13	3	F-M1				
WT	+14	3#	C-M1-2				5
WT	15	3	<-BRACE				
WT	16	3	K-DIR				
WT	17	3	+20.0				3
WT	18	3	R-TT2				2
WT	19	3	YBI-END				
WT	20	3	TEST-3				
WT	21	3	B-INDIC				9
WT	22	3					
WT	23	3	+24.0				
WT	24	3	-5.8				
WT	25	3	+5.8				

EL: 05 SPOOLING MOTOR CONTROL PC CARD

TYPE	PT	LV	SIG-NAME	COLOR	F	X	Y
WT	01	3	+0.0				0
WT	02	3	+0.0				0
WT	03	3	QPWR2-1				1
WT	04	3	QPWR2-2				4
WT	05	3	B-FORW				
WT	06	3	T-M2				
WT	07	3	YAN-M2				
WT	08	3	QPWR2-3				9
WT	09	3	R-TT2				
WT	10	3	Y-ACCEL				5

GR: 20 (CONTINUATION)
 CONTROL UNIT, CARD CHASSIS

EL: 05 (CONTINUATION)

TYPE	PT	LV	SIG.NAME	COLOR	F	X	Y
WT	11	3	YBI-MOVE				
WT	12	3	Y-CUTAUT				
WT	12K	0	KEY				
WT	13	3	R-CUT-3	7			
WT	14	3	K-LIFI				
WT	15	3	R-CUT-1	5			
WT	16	3	R-TT1	1			
WT	17	3	B-REW				
WT	18	3	T-M1				
WT	19	3	YAN-M1				
WT	20	3	QPWR1-3	8			
WT	21	3	QPWR1-2	5			
WT	22	3	QPWR1-1	2			
WT	23	3	+20.0	3			
WT	24	3	- 5.8				
WT	25	3					

EL: 06 CAPSTAN SERVJ PC CARD

TYPE	PT	LV	SIG.NAME	COLOR	F	X	Y
WT	01A	3					
WT	01B	3	+ 0.0	0			
WT	02A	3					
WT	02B	3	+ 0.0	0			
WT	02K	0	KEY				
WT	03A	3					
WT	03B	3	YAC2-M3	5			
WT	04A	3					
WT	04B	3	YAC1-M3	4			
WT	05A	3					
WT	05B	3	0-YAC2	0			
WT	06A	3					
WT	06B	3	0-YAC1	0			
WT	07A	3					
WT	07B	3	0-YAC3	0			
WT	08A	3					
WT	08B	3	YAC3-2	1			
WT	09A	3					
WT	09B	3	YAC3-1	4			
WT	10A	3					
WT	10B	3					
WT	11A	3					
WT	11B	3	S-LDW				
WT	12A	3					
WT	12B	3	YAN-M3-2	9			
WT	13A	3					
WT	13B	3	YAN-M3-1	7			
WT	14A	3					
WT	14B	3	+20.0	3			
WT	15A	3					

GR: 20 (CONTINUATION)
 CONTROL UNIT, CARD CHASSIS

EL: 06 (CONTINUATION)

TYPE	PT	LV	SIG.NAME	COLOR	F	X	Y
WT	+ 15B	3#	C-M3-2	8			
WT	16A	3					
WT	+ 16B	3#	T-M3	1			
WT	17A	3					
WT	17B	3	F-M3				
WT	18A	3					
WT	18B	3	M3-1	6			
WT	19A	3					
WT	19B	3					
WT	20A	3					
WT	20B	3	QPWR3-3	7			
WT	21A	3					
WT	21B	3	QPWR3-2	9			
WT	22A	3					
WT	22B	3	QPWR3-1	4			
WT	23A	3					
WT	23B	3	+24.0	2			
WT	24A	3					
WT	24B	3	- 5.8	6			
WT	25A	3					
WT	25B	3	+ 5.8	5			

EL: 08 IC DECODER PC CARD

TYPE	PT	LV	SIG.NAME	COLOR	F	X	Y
WT	01A	3	+ 0.0				
WT	01B	3	+ 0.0				
WT	02A	3	+ 0.0				
WT	02B	3	+ 0.0				
WT	03A	3					
WT	03B	3	YBI-MOVE				
WT	04A	3					
WT	04B	3	Q-MOVE				
WT	05A	3					
WT	05B	3	YBI-CUT				
WT	06A	3	B-DIR	9			
WT	06B	3	YBI-FF0	6			
WT	07A	3	B-MOVE				
WT	07B	3	YBI-FF2				
WT	08A	3	B-REPR	4			
WT	08B	3	K-CUT	5			
WT	09A	3					
WT	09B	3	YBI-FF3				
WT	10A	3					
WT	10B	3	YBI-FF1				
WT	10K	0	KEY				
WT	11A	3					
WT	11B	3	YBI-FF4				
WT	12A	3#	B-REW	2			
WT	12B	3	B-STOP	1			

GR: 20 (CONTINUATION)
 CONTROL UNIT, CARD CHASSIS

EL: 08 (CONTINUATION)

TYPE	PT	LV	SIG.NAME	COLOR	F	X	Y
WT	13A	3					
WT	13B	3#	B-FORW	3			
WT	14A	3					
WT	14B	3	Y-CJTAUT				
WT	15A	3#	K-PRESS	8			
WT	15B	3	TEST-B				
WT	+ 16A	3#	S-TT	4			
WT	16B	3	+ 0.0				
WT	+ 17A	3#	<-TT1/2	7			
WT	17B	3N	YBI-LL				
WT	18A	3*	B-CUT	6			
WT	18B	3	< BRAK				
WT	19A	3					
WT	19B	3	YBI-DIR				
WT	20A	3	<-DIR				
WT	20B	3#	K-LIFT	3			
WT	21A	3	+0-CUTAU	0			
WT	21B	3	S-CUTAUT	1			
WT	22A	3	K-TT	9			
WT	22B	3	YBI-REC				
WT	23A	3	+24.0	2			
WT	23B	3	+24.0	2			
WT	24A	3	- 5.8	6			
WT	24B	3	- 5.8				
WT	25A	3	+ 5.8	5			
WT	25B	3	+ 5.8				

EL: 09 IC MEMORY & COUNTER PC CARD

TYPE	PT	LV	SIG.NAME	COLOR	F	X	Y
WT	01A	3	+ 0.0	0			
WT	01B	3	+ 0.0				
WT	02A	3	+ 0.0				
WT	02B	3	+ 0.0				
WT	03A	3	YBI-END				
WT	03B	3					
WT	04A	3	YPS-REC				
WT	04B	3	YBI-CUT				
WT	05A	3	YBI-FF1				
WT	05B	3	YBI-MOVE				
WT	06A	3	YPS-STP				
WT	06B	3N	YBI-MOV2				
WT	07A	3	YPS-REPR				
WT	07B	3	YBI-FF0				
WT	08A	3	YPS-FORW				
WT	08B	3	YBI-FF2				
WT	09A	3	YPS-REW				
WT	09B	3	YBI-FF3				
WT	10A	3	YPS-CUT				
WT	10B	3	YBI-FF4				

GR: 20 (CONTINUATION)
 CONTROL UNIT, CARD CHASSIS

EL: 09 (CONTINUATION)

TYPE	PT	LV	SIG.NAME	COLOR	F	X	Y
WT	11A	3					
WT	11B	3	YBI-FAD				
WT	12A	3	+0-DIR1	0			
WT	12B	3	QP-DIR1	8			
WT	13A	3N	+0-DIR2				
WT	13B	3	QP-DIR2	7			
WT	14A	3					
WT	14B	3					
WT	15A	3					
WT	15B	3	M4-3	5			
WT	16A	3	M4-4	6			
WT	16B	3					
WT	17A	3N	+0-CLK				
WT	17B	3N	YBI-CLK				
WT	18A	3					
WT	18B	3	YBI-DIR				
WT	19A	3					
WT	19B	3					
WT	+ 20A	3	K-RESET	1			
WT	20B	3					
WT	20K	0	KEY				
WT	21A	3	B-REC	5			
WT	21B	3	YBI-LOW				
WT	22A	3	M4-1	3			
WT	22B	3	M4-2	4			
WT	23A	3	+24.0	2			
WT	23B	3	+24.0	2			
WT	24A	3					
WT	24B	3					
WT	25A	3	+ 5.8				
WT	25B	3	+ 5.8	5			

EL: 10 ATTENUATOR & PREAMP. PC CARD

TYPE	PT	LV	SIG.NAME	COLOR	F	X	Y
WT	01A	3	+ 0.0	0			
WT	01B	3	+ 0.0	0			
WT	02A	3	+ 0.0				
WT	02B	3	+ 0.0				
WT	03A	3	+0-MOVE	0			
WT	03B	3	QP-MOVE	4			
WT	04A	3	+0-END	0			
WT	04B	3	RP-END	8			
WT	05A	3	Y-REC				
WT	05B	3	Q-MOVE				
WT	06A	3	YBI-REC				
WT	06B	3	YBI-END				
WT	07A	3	K-PRESS				
WT	07B	3	+16.0	3			
WT	08A	3	B-FAD	1			

GR: 20 (CONTINUATION)
 CONTROL UNIT, CARD CHASSIS

EL: 10 (CONTINUATION)

TYPE	PT	LV	SIG.NAME	COLOR	F	X	Y
WT	08B	3	YPS-REC				
WT	+ 09A	3	REM-IN	7			
WT	09B	3	B-CUT				
WT	10A	3					
WT	10B	3	S-CUT	6			
WT	11A	3					
WT	11B	3	S-REC	5			
WT	12A	3					
WT	12B	3	YPS-REPR				
WT	13A	3	FAD-2	9			
WT	13B	3	S-REPR	4			
WT	14A	3					
WT	14B	3	YPS-FORW				
WT	15A	3	FAD-1	8			
WT	15B	3*	S-FORW	3			
WT	16A	3*	YPS-MOVE	7			
WT	16B	3	YPS-REW				
WT	16K	0	KEY				
WT	17A	3	YPS-STOP				
WT	17B	3*	S-REW	2			
WT	18A	3	S-LDW				
WT	18B	3*	S-STOP	1			
WT	19A	3					
WT	19B	3	YPS-CUT				
WT	20A	3					
WT	20B	3	YBI-FAD				
WT	21A	3	YBI-LOW				
WT	21B	3	K-FAD-1	8			
WT	22A	3					
WT	22B						

GR: 21 1.080.426.00
 CAPSTAN SPEED CONTROL CONNECTOR, REMOTE

GR: 22 1.080.426.00
 MODE CONTROL CONNECTOR, REMOTE

GR: 23 1.080.351.00
 TIME ELAPSE METER, CABLE PLUG

EL: 21 CAPSTAN SPEED CONTROL CONNECTOR

TYPE	PT	LV	SIG.NAME	COLOR	F	X	Y
L	01	1@	+ 0.0	0			
L	02	1@	+24.0	2			
L	03	1@	+ 5.8	5			
L	04	1					
L	05	1	YAN-M3-1	7			
L	06	1					
L	07	1	YAC3-1	4			
L	08	1@	+ 0.0	0			
L	09	1					
L	10	1@	- 5.8	6			
L	11	1					
L	12	1	YAN-M3-2	9			
L	13	1	0-YAC3	0			
L	14	1	YAC3-2	1			

EL: 22 MODE CONTROL CONNECTOR, REMOTE

TYPE	PT	LV	SIG.NAME	COLOR	F	X	Y
L	01	1	B-INDIC	9			
L	02	1	B-REW	2			
L	03	1	B-FORW	3			
L	04	1	B-REPR	4			
L	05	1	B-STOP	1			
L	06	1	B-REC	5			
L	07	1	B-CUT	6			
L	08	1	B-MONO	3			
L	09	1	YPS-MOVE	7			
L	10	1	B-FAD	1			
L	11	1	FAD-1	8			
L	12	1@	+24.0	2			
L	13	1					
L	14	1					
L	15	1@	- 5.8	6			
L	16	1	M4-2	4			
L	17	1	M4-4	6			
L	18	1@	+24.0	2			
L	19	1	REM-IN	7			
L	20	1	S-REW	2			
L	21	1	S-FORW	3			
L	22	1	S-REPR	4			
L	23	1	S-STOP	1			
L	24	1	S-REC	5			
L	25	1	S-CUT	6			
L	26	1	S-MONO	3			
L	27	1@	S-HIGH	4			
L	28	1	S-ZLOCAT	7			
L	29	1	FAD-2	9			
L	30	1@	+ 0.0	0			
L	31	1R	+0-TYPE				
L	32	1@	+ 5.8	5			
L	33	1	K-RESET	1			
L	34	1	M4-1	3			
L	35	1	M4-3	5			
L	36	1@	+ 0.0	0			

EL: 23 FEED TO TIME ELAPSE METER

TYPE	PT	LV	SIG.NAME	COLOR	F	X	Y
G	01	1@	+24.0	2			
G	03	1@	K-LIFT	3			

GR #	USED PINS	UNUSED PINS	TOTAL PINS	COD. KEYS	ELE-MNTS	DESCRIPTION OF GROUP	PART # OF GR
01	14	5	19	0	5	REAR PANEL ASSEMBLY	1.080.730.00
02	169	11	180	0	19	POWER SUPPLY ASSEMBLY	1.080.320.00
03	8	2	10	0	2	EXTENSION CABLE-PWR SUPPLY-MAINS SWITCH	1.080.288.00
04	32	0	32	0	13	PWR TRANSISTORS & PHASE SHIFT CAPACITORS	1.080.415.00
05	14	3	17	0	5	TAPE SPEED & POWER SWITCH ASSEMBLY	1.080.283.00
06	3	0	3	0	1	CONTROL UNIT, SPEED SELECTOR CABLE PLUG	1.080.420.00
07	3	2	5	0	1	CONTROL UNIT, SUPPLY MOTOR, CABLE PLUG	1.080.420.00
08	2	1	3	0	1	FEED TO BRAKE LIFT SOLENOID LEFT	1.080.420.00
09	2	1	3	0	1	FEED TO BRAKE LIFT SOLENOID RIGHT	1.080.420.00
10	3	2	5	0	1	CONTROL UNIT, TAKE-UP MOTOR, CABLE PLUG	1.080.420.00
11	5	0	5	0	1	FEED TO TAPE TENSION CONTROL LEFT	1.080.420.00
12	5	0	5	0	1	FEED TO TAPE TENSION CONTROL RIGHT	1.080.420.00
13	4	1	5	0	1	FEED TO OPTICAL TAPE SENSOR	1.080.420.00
14	11	1	12	0	2	FEED TO TAPE MOVE & DIRECTION SENSOR	1.080.420.00
15	5	0	5	0	1	FEED TO PRESSURE ROLLER ASSEMBLY	1.080.420.00
16	7	1	8	0	1	CONTROL UNIT, CAPSTAN MOTOR, CABLE PLUG	1.080.420.00
17	15	0	15	0	1	FEED TO LOCAL COMMAND SWITCHES	1.080.420.00
18	20	2	22	1	3	FEED TO LOCAL TAPE TIMER	1.080.420.00
19	5	0	5	0	1	CONTROL UNIT, CUTTER CONTROL, CABLE PLUG	1.080.420.00
20	264	65	329	8	11	CONTROL UNIT, CARD CHASSIS	1.080.351.00
21	10	4	14	0	1	CAPSTAN SPEED CONTROL CONNECTOR, REMOTE	1.080.425.00
22	34	2	36	0	1	MODE CONTROL CONNECTOR, REMOTE	1.080.426.00
23	2	0	2	0	1	TIME ELAPSE METER, CABLE PLUG	1.080.351.00
TOT.	637	103	740	9	75	DISTRIBUTED IN 23 GROUPS	

DESCRIPTION OF ELEMENT	GR EL PT	DESCRIPTION OF ELEMENT	GR EL PT	DESCRIPTION OF ELEMENT	GR EL PT
POWER FEED CONNECTOR, MAINS	01 08 02	SPOOLING MOTOR CONTROL PC CARD	20 05 25	ATTENUATOR & PREAMP. PC CARD	20 10 19A
POWER FEED CONNECTOR, MAINS	01 08 04			ATTENUATOR & PREAMP. PC CARD	20 10 20A
POWER FEED CONNECTOR, MAINS	01 08 06	CAPSTAN SERVO PC CARD	20 06 01A	ATTENUATOR & PREAMP. PC CARD	20 10 22A
POWER FEED CONNECTOR, MAINS	01 08 07	CAPSTAN SERVO PC CARD	20 06 02A		
POWER FEED CONNECTOR, MAINS	01 08 08	CAPSTAN SERVO PC CARD	20 06 03A	ZERO LOCATOR PC CARD	20 11 07
		CAPSTAN SERVO PC CARD	20 06 04A	ZERO LOCATOR PC CARD	20 11 08
POWER INPUT FEED CONNECTOR	02 01 02	CAPSTAN SERVO PC CARD	20 06 05A	ZERO LOCATOR PC CARD	20 11 13
POWER INPUT FEED CONNECTOR	02 01 04	CAPSTAN SERVO PC CARD	20 06 06A	ZERO LOCATOR PC CARD	20 11 22
POWER INPUT FEED CONNECTOR	02 01 06	CAPSTAN SERVO PC CARD	20 06 07A		
POWER INPUT FEED CONNECTOR	02 01 07	CAPSTAN SERVO PC CARD	20 06 08A	CAPSTAN SPEED CONTROL CONNECTOR	21 21 04
POWER INPUT FEED CONNECTOR	02 01 08	CAPSTAN SERVO PC CARD	20 06 09A	CAPSTAN SPEED CONTROL CONNECTOR	21 21 06
		CAPSTAN SERVO PC CARD	20 06 10A	CAPSTAN SPEED CONTROL CONNECTOR	21 21 09
POWER SWITCH FEED, RECEPTACLE	02 08 03	CAPSTAN SERVO PC CARD	20 06 10B	CAPSTAN SPEED CONTROL CONNECTOR	21 21 11
		CAPSTAN SERVO PC CARD	20 06 11A		
CHANNEL FEED CONNECTOR	02 20 10	CAPSTAN SERVO PC CARD	20 06 12A	MODE CONTROL CONNECTOR, REMOTE	22 22 13
CHANNEL FEED CONNECTOR	02 20 12	CAPSTAN SERVO PC CARD	20 06 13A	MODE CONTROL CONNECTOR, REMOTE	22 22 14
		CAPSTAN SERVO PC CARD	20 06 14A		
FEED CONNECTOR, SYNCHRONIZ. OPT.	02 21 05	CAPSTAN SERVO PC CARD	20 06 15A		
FEED CONNECTOR, SYNCHRONIZ. OPT.	02 21 10	CAPSTAN SERVO PC CARD	20 06 16A		
FEED CONNECTOR, SYNCHRONIZ. OPT.	02 21 12	CAPSTAN SERVO PC CARD	20 06 17A		
		CAPSTAN SERVO PC CARD	20 06 18A		
EXTENSION CABLE, SUPPLY SIDE	03 01 03	CAPSTAN SERVO PC CARD	20 06 19A		
		CAPSTAN SERVO PC CARD	20 06 19B		
EXTENSION CABLE, SWITCH SIDE	03 02 03	CAPSTAN SERVO PC CARD	20 06 20A		
		CAPSTAN SERVO PC CARD	20 06 21A		
POWER SWITCH FEED, JACK	05 01 03	CAPSTAN SERVO PC CARD	20 06 22A		
		CAPSTAN SERVO PC CARD	20 06 23A		
POWER SWITCH, REAR	05 02 02	CAPSTAN SERVO PC CARD	20 06 24A		
		CAPSTAN SERVO PC CARD	20 06 25A		
POWER SWITCH, FRONT	05 03 02				
SUPPLY MOTOR (M1)	07 01 02	IC DECODER PC CARD	20 08 03A		
SUPPLY MOTOR (M1)	07 01 04	IC DECODER PC CARD	20 08 04A		
		IC DECODER PC CARD	20 08 05A		
BRAKE LIFT SOLENOID, LEFT	08 01 03	IC DECODER PC CARD	20 08 09A		
		IC DECODER PC CARD	20 08 10A		
BRAKE LIFT SOLENOID, RIGHT	09 01 03	IC DECODER PC CARD	20 08 11A		
		IC DECODER PC CARD	20 08 13A		
		IC DECODER PC CARD	20 08 14A		
TAKE-UP MOTOR (M2)	10 01 02	IC DECODER PC CARD	20 08 19A		
TAKE-UP MOTOR (M2)	10 01 04				
		IC MEMORY & COUNTER PC CARD	20 09 03B		
OPTICAL TAPE END SENSOR	13 01 04	IC MEMORY & COUNTER PC CARD	20 09 11A		
		IC MEMORY & COUNTER PC CARD	20 09 14A		
TAPE MOVE SENSOR	14 01 05	IC MEMORY & COUNTER PC CARD	20 09 14B		
		IC MEMORY & COUNTER PC CARD	20 09 15A		
CAPSTAN MOTOR ASSEMBLY	16 01 06	IC MEMORY & COUNTER PC CARD	20 09 16B		
		IC MEMORY & COUNTER PC CARD	20 09 18A		
TIMER FEED 11-POLE CIS PLUG	18 02 07	IC MEMORY & COUNTER PC CARD	20 09 19A		
TIMER FEED 11-POLE CIS PLUG	18 02 08	IC MEMORY & COUNTER PC CARD	20 09 19B		
		IC MEMORY & COUNTER PC CARD	20 09 20B		
POWER CONNECTOR PC CARD	20 01 10	IC MEMORY & COUNTER PC CARD	20 09 24A		
POWER CONNECTOR PC CARD	20 01 13	IC MEMORY & COUNTER PC CARD	20 09 24B		
POWER CONNECTOR PC CARD	20 01 18				
+24/+20/+6/-6V STABIL. PC CARD	20 02 04	ATTENUATOR & PREAMP. PC CARD	20 10 10A		
		ATTENUATOR & PREAMP. PC CARD	20 10 11A		
		ATTENUATOR & PREAMP. PC CARD	20 10 12A		
CONTACTOR PC CARD	20 04 22	ATTENUATOR & PREAMP. PC CARD	20 10 14A		

SIG. NAME	COLOR	TYPE	GR EL PT	S	DESCRIPTION OF ELEMENT	SIG. NAME	COLOR	TYPE	GR EL PT	S	DESCRIPTION OF ELEMENT
0-AC1	6	Y	02 05 38		RECTIFIER & CONNECTOR PC CARD	(CONT.)	WT	20 10 02B			ATTENUATOR & PREAMP. PC CARD
		L	02 20 06		CHANNEL FEED CONNECTOR		WT	20 11 01			ZERO LOCATOR PC CARD
							WT	20 11 02			ZERO LOCATOR PC CARD
0-AC2	7	Y	02 05 39		RECTIFIER & CONNECTOR PC CARD		W	20 16 01	#		BUSS BARS, LOWER
		L	02 20 07		CHANNEL FEED CONNECTOR		L	21 21 01	@		CAPSTAN SPEED CONTROL CONNECTOR
							L	21 21 08	@		CAPSTAN SPEED CONTROL CONNECTOR
0-AC3	6	Y	02 05 42		RECTIFIER & CONNECTOR PC CARD		L	22 22 30	@		MODE CONTROL CONNECTOR, REMOTE
		L	02 21 06		FEED CONNECTOR, SYNCHRONIZ. OPT.		L	22 22 36	@		MODE CONTROL CONNECTOR, REMOTE
0-AC4	7	Y	02 05 43		RECTIFIER & CONNECTOR PC CARD	+ 0.0(1) 0	Y	02 05 60			RECTIFIER & CONNECTOR PC CARD
		L	02 21 07		FEED CONNECTOR, SYNCHRONIZ. OPT.						
0-YAC1	0	M	16 01 04		CAPSTAN MOTOR ASSEMBLY	+ 0.0(2) 0	Y	02 05 73			RECTIFIER & CONNECTOR PC CARD
		WT	20 06 06B		CAPSTAN SERVO PC CARD		L	02 16 32	*		CHARGE CAPACITOR, +24.0 V (1)
							L	02 17 02			CHARGE CAPACITOR, +24.0 V (2)
0-YAC2	0	M	16 01 07		CAPSTAN MOTOR ASSEMBLY	+ 0.0(3) 0	Y	02 05 81			RECTIFIER & CONNECTOR PC CARD
		WT	20 06 05B		CAPSTAN SERVO PC CARD		Y	02 05 82			RECTIFIER & CONNECTOR PC CARD
0-YAC3	0	WT	20 06 07B		CAPSTAN SERVO PC CARD	+ 0.0(4) 0	Y	02 19 01	*		CHARGE CAPACITOR, + 5.8 V
		L	21 21 13		CAPSTAN SPEED CONTROL CONNECTOR		Y	02 05 93			RECTIFIER & CONNECTOR PC CARD
+ 0.0	0	L	02 05 12	@	RECTIFIER & CONNECTOR PC CARD		Y	02 05 94			RECTIFIER & CONNECTOR PC CARD
		L	02 05 13	@	RECTIFIER & CONNECTOR PC CARD		L	02 19 32	*		CHARGE CAPACITOR, + 5.8 V
		L	02 05 14	@	RECTIFIER & CONNECTOR PC CARD						
		SL	04 03 01	@	DC CHASSIS CONNECTION	+ 5.8	5	L	02 05 20	@	RECTIFIER & CONNECTOR PC CARD
		L	05 04 01	@	TAPE SPEED SELECTOR SWITCH		P	14 01 32	@		TAPE MOVE SENSOR
		F	05 05 01	@	SPEED SELECTOR FEED, JACK		P	14 02 02	@		TAPE DIRECTION SENSOR
		M	06 01 01	@	SPEED SELECTOR, CABLE PLUG		P	18 01 09	@		TIMER FEED PC-CARD PLUG
		M	11 01 03	@	TAPE TENSION CONTROL ASSY, LEFT		F	18 03 03	@		TIMER FEED 3-POLE MOLEX PLUG
		M	12 01 03	@	TAPE TENSION CONTROL ASSY, RIGHT		WTL	20 01 25			POWER CONNECTOR PC CARD
		P	18 01 02	@	TIMER FEED PC-CARD PLUG		WT	20 02 25			+24/+20/+6/-6V STABIL. PC CARD
		WTL	20 01 01	D	POWER CONNECTOR PC CARD		WT	20 04 25			CONTACTOR PC CARD
		WTL	20 01 02	D	POWER CONNECTOR PC CARD		WT	20 06 25B			CAPSTAN SERVO PC CARD
		WTL	20 01 24		POWER CONNECTOR PC CARD		WT	20 08 25A			IC DECODER PC CARD
		WT	20 02 01		+24/+20/+6/-6V STABIL. PC CARD		WT	20 08 25B			IC DECODER PC CARD
		WT	20 02 02		+24/+20/+6/-6V STABIL. PC CARD		WT	20 09 25A			IC MEMORY & COUNTER PC CARD
		WT	20 02 19		+24/+20/+6/-6V STABIL. PC CARD		WT	20 09 25B			IC MEMORY & COUNTER PC CARD
		WT	20 02 20		+24/+20/+6/-6V STABIL. PC CARD		WT	20 10 25A			ATTENUATOR & PREAMP. PC CARD
		WT	20 04 01		CONTACTOR PC CARD		WT	20 10 25B			ATTENUATOR & PREAMP. PC CARD
		WT	20 04 02		CONTACTOR PC CARD		WT	20 11 25			ZERO LOCATOR PC CARD
		WT	20 05 01		SPOOLING MOTOR CONTROL PC CARD		W	20 13 02	#		BUSS BARS, UPPER
		WT	20 05 02		SPOOLING MOTOR CONTROL PC CARD		L	21 21 03	@		CAPSTAN SPEED CONTROL CONNECTOR
		WT	20 06 01B		CAPSTAN SERVO PC CARD		L	22 22 32	@		MODE CONTROL CONNECTOR, REMOTE
		WT	20 06 02B		CAPSTAN SERVO PC CARD						
		WT	20 08 01A		IC DECODER PC CARD	+0-CLK	WT	20 09 17A	N		IC MEMORY & COUNTER PC CARD
		WT	20 08 01B		IC DECODER PC CARD						
		WT	20 08 02A		IC DECODER PC CARD	+0-CUTAU 0	M	19 01 35			CUTTER CONTROL ASSEMBLY
		WT	20 09 02B		IC DECODER PC CARD		WT	20 08 21A			IC DECODER PC CARD
		WT	20 08 16B		IC DECODER PC CARD						
		WT	20 09 01A		IC MEMORY & COUNTER PC CARD	+0-DIR1 0	P	14 02 04			TAPE DIRECTION SENSOR
		WT	20 09 01B		IC MEMORY & COUNTER PC CARD		WT	20 09 12A			IC MEMORY & COUNTER PC CARD
		WT	20 09 02A		IC MEMORY & COUNTER PC CARD						
		WT	20 09 02B		IC MEMORY & COUNTER PC CARD	+0-DIR2	WT	20 09 13A	N		IC MEMORY & COUNTER PC CARD
		WT	20 10 01A		ATTENUATOR & PREAMP. PC CARD						
		WT	20 10 01B		ATTENUATOR & PREAMP. PC CARD	+0-END 0	M	13 01 02			OPTICAL TAPE END SENSOR
		WT	20 10 02A		ATTENUATOR & PREAMP. PC CARD		WT	20 10 04A			ATTENUATOR & PREAMP. PC CARD

SIG.	NAME	COLOR	TYPE	GR	EL	PT	S	DESCRIPTION OF ELEMENT	SIG.	NAME	COLOR	TYPE	GR	EL	PT	S	DESCRIPTION OF ELEMENT	
+0-MOVE	0		P	14	01	04		TAPE MOVE SENSOR	(CONT.)		L	02	20	05			CHANNEL FEED CONNECTOR	
			WT	20	10	03A		ATTENUATOR & PREAMP. PC CARD										
+0-1YPE			L	22	22	31	R	MODE CONTROL CONNECTOR, REMOTE	+31.0	9	L	02	05	17			RECTIFIER & CONNECTOR PC CARD	
																	# +24.0 V STABILIZER TRANSISTOR	
+10.0	8		L	02	05	19		RECTIFIER & CONNECTOR PC CARD			WTL	20	01	19			POWER CONNECTOR PC CARD	
			WTL	20	01	22		POWER CONNECTOR PC CARD			WT	20	02	06				+24/+20/+6/-6V STABIL. PC CARD
			WT	20	02	21		+24/+20/+6/-6V STABIL. PC CARD	+31.0(N)		WT	20	02	05	N			+24/+20/+6/-6V STABIL. PC CARD
+10.0(0)	8		Y	02	05	91		RECTIFIER & CONNECTOR PC CARD	+31.0(0)	9	Y	02	05	71			RECTIFIER & CONNECTOR PC CARD	
			Y	02	05	92		RECTIFIER & CONNECTOR PC CARD			Y	02	05	72			RECTIFIER & CONNECTOR PC CARD	
			L	02	18	01	*	* CHARGE CAPACITOR, + 5.8 V			L	02	16	01	*		* CHARGE CAPACITOR, +24.0 V (1)	
											L	02	17	01			CHARGE CAPACITOR, +24.0 V (2)	
+16.0	3		M	13	01	01		OPTICAL TAPE END SENSOR	- 5.8	6	P	18	01	01			TIMER FEED PC-CARD P.JG	
			WT	20	10	07B		ATTENUATOR & PREAMP. PC CARD			WT	20	02	14			+24/+20/+6/-6V STABIL. PC CARD	
+20.0	3		H	04	08	01		+20.0 V STABILIZER TRANSISTOR			WT	20	04	24			CONTACTOR PC CARD	
			M	11	01	01		TAPE TENSION CONTROL ASSY, LEFT			WT	20	05	24				SPOOLING MOTOR CONTRL PC CARD
			M	12	01	01		TAPE TENSION CONTROL ASSY, RIGHT			WT	20	06	24B				CAPSTAN SERVO PC CARD
			M	19	01	02		CUTTER CONTROL ASSEMBLY			WT	20	08	24A				IC DECODER PC CARD
			WT	20	02	09		+24/+20/+6/-6V STABIL. PC CARD			WT	20	08	24B				IC DECODER PC CARD
			WT	20	02	10		+24/+20/+6/-6V STABIL. PC CARD			WT	20	10	24A				ATTENUATOR & PREAMP. PC CARD
			WT	20	04	17		CONTACTOR PC CARD			WT	20	10	24B				ATTENUATOR & PREAMP. PC CARD
			WT	20	05	23		SPOOLING MOTOR CONTROL PC CARD			WT	20	11	24				ZERO LOCATOR PC CARD
			WT	20	06	14B		CAPSTAN SERVO PC CARD			W	20	14	02				# BUSS BARS, LOWER
+24.0	2		L	02	05	06		RECTIFIER & CONNECTOR PC CARD			L	21	21	10			@ CAPSTAN SPEED CONTROL CONNECTOR	
			H	04	04	01		+24.0 V STABILIZER TRANSISTOR	-10.0	6	L	02	05	18			RECTIFIER & CONNECTOR PC CARD	
			F	08	08	03		+20.0 V STABILIZER TRANSISTOR			WTL	20	01	21			POWER CONNECTOR PC CARD	
			F	08	01	01		BRAKE LIFT SOLENOID, LEFT			WT	20	02	18				+24/+20/+6/-6V STABIL. PC CARD
			F	09	01	01		BRAKE LIFT SOLENOID, RIGHT										
			P	14	01	01		TAPE MOVE SENSOR										
			P	14	02	01		TAPE DIRECTION SENSOR	-10.0(0)	6	Y	02	05	83			RECTIFIER & CONNECTOR PC CARD	
			F	15	01	01		PRESSURE ROLLER ASSEMBLY			Y	02	05	84			RECTIFIER & CONNECTOR PC CARD	
			P	18	01	04		TIMER FEED PC-CARD PLUG			L	02	19	02	*		* CHARGE CAPACITOR, - 5.8 V	
			WTL	20	01	23		POWER CONNECTOR PC CARD	AC1	6	Y	02	05	40			RECTIFIER & CONNECTOR PC CARD	
			WT	20	02	11		+24/+20/+6/-6V STABIL. PC CARD			L	02	20	13			CHANNEL FEED CONNECTOR	
			WT	20	02	12		+24/+20/+6/-6V STABIL. PC CARD										
			WT	20	04	03		CONTACTOR PC CARD	AC2	7	Y	02	05	41			RECTIFIER & CONNECTOR PC CARD	
			WT	20	04	04		CONTACTOR PC CARD			L	02	20	14			CHANNEL FEED CONNECTOR	
			WT	20	04	23		CONTACTOR PC CARD										
			WT	20	06	23B		CAPSTAN SERVO PC CARD	AC3	6	Y	02	05	44			RECTIFIER & CONNECTOR PC CARD	
			WT	20	08	23A		IC DECODER PC CARD			L	02	21	13			FEED CONNECTOR, SYNCHRONIZ. OPT.	
			WT	20	08	23B		IC DECODER PC CARD										
			WT	20	09	23A		IC MEMORY & COUNTER PC CARD	AC4	7	Y	02	05	45			RECTIFIER & CONNECTOR PC CARD	
			WT	20	09	23B		IC MEMORY & COUNTER PC CARD			L	02	21	14			FEED CONNECTOR, SYNCHRONIZ. OPT.	
			WT	20	10	23A		ATTENUATOR & PREAMP. PC CARD										
			WT	20	10	23B		ATTENUATOR & PREAMP. PC CARD	B-CUT	6	P	17	01	02			COMMAND SWITCHES, LOCAL	
			WT	20	11	23		ZERO LOCATOR PC CARD			WT	20	08	18A	*		IC DECODER PC CARD	
			WL	20	13	01	#	BUSS BARS, UPPER			WT	20	10	07B			ATTENUATOR & PREAMP. PC CARD	
			L	21	21	02		CAPSTAN SPEED CONTROL CONNECTOR			L	22	22	07			MODE CONTROL CONNECTOR, REMOTE	
			L	22	22	12		MODE CONTROL CONNECTOR, REMOTE	B-DIR	9	P	14	02	06			TAPE DIRECTION SENSOR	
			L	22	22	16		MODE CONTROL CONNECTOR, REMOTE			WT	20	08	06A			IC DECODER PC CARD	
			G	23	23	01		FEED TO TIME ELAPSE METER										
+24.0(1)	2		Y	02	05	59		RECTIFIER & CONNECTOR PC CARD										

SIG.	NAME	COLOR	TYPE	GR	EL	PT	S	DESCRIPTION OF ELEMENT	SIG.	NAME	COLOR	TYPE	GR	EL	PT	S	DESCRIPTION OF ELEMENT
B-END	7		F	13	01	05		OPTICAL TAPE END SENSOR	(CONT.)		WT	20	11	06			ZERO LOCATOR PC CARD
			WT	20	10	22B		ATTENUATOR & PREAMP. PC CARD									
B-FAD	1		WT	20	10	08A		ATTENUATOR & PREAMP. PC CARD	C-M1-2	5	L	04	05	02			SUPPLY MOTOR CAPACITOR, ADD.
			L	22	22	10		MODE CONTROL CONNECTOR, REMOTE			L	04	14	02			SUPPLY MOTOR CAPACITOR, MAIN
B-FORW	3		P	17	01	06		COMMAND SWITCHES, LOCAL			F	07	01	05			SUPPLY MOTOR (M1)
			WT	20	05	05		SPOOLING MOTOR CONTROL PC CARD			WT +	20	04	14			# CONTACTOR PC CARD
			WT	20	08	13B	#	IC DECODER PC CARD	C-M2-2	8	L	04	01	02			TAKE-UP MOTOR CAPACITOR, ADD.
			L	22	22	03		MODE CONTROL CONNECTOR, REMOTE			L	04	13	02			TAKE-UP MOTOR CAPACITOR, MAIN
B-INDIC	9		P	17	01	01		COMMAND SWITCHES, LOCAL			F	10	01	03			TAKE-UP MOTOR (M2)
			WT	20	04	21		CONTACTOR PC CARD			WT +	20	04	09			# CONTACTOR PC CARD
			L	22	22	01		MODE CONTROL CONNECTOR, REMOTE	C-M3-2	8	L	04	07	02			CAPSTAN MOTOR CAPACITOR
B-MONO	3		L	02	05	03		RECTIFIER & CONNECTOR PC CARD			M	16	01	03			CAPSTAN MOTOR ASSEMBLY
			WTL	20	01	07		POWER CONNECTOR PC CARD			WT +	20	05	15B	#		CAPSTAN SERVO PC CARD
			L	22	22	08		MODE CONTROL CONNECTOR, REMOTE	D-ZLOCAT	4	M	18	03	01			TIMER FEED 3-POLE MOLEX PLUG
B-MONO-I	8		Y	02	05	35	*	RECTIFIER & CONNECTOR PC CARD			WT	20	11	21			ZERO LOCATOR PC CARD
			L	02	20	08		CHANNEL FEED CONNECTOR	DIG10**0	6	N	18	02	10			TIMER FEED 11-POLE CIS PLUG
			L	02	21	08		FEED CONNECTOR, SYNCHRONIZ. OPT.			WT	20	11	09			ZERO LOCATOR PC CARD
B-MOVE	6		P	14	01	06		TAPE MOVE SENSOR	DIG10**1	5	N	18	02	09			TIMER FEED 11-POLE CIS PLUG
			WT	20	08	07A		IC DECODER PC CARD			WT	20	11	10			ZERO LOCATOR PC CARD
B-REC	5		P	17	01	03		COMMAND SWITCHES, LOCAL	F(+ 5.8)	2	L	02	05	95			RECTIFIER & CONNECTOR PC CARD
			WT	20	09	21A		IC MEMORY & COUNTER PC CARD			L	02	14	01			FUSE, + 5.8 V
			L	22	22	06		MODE CONTROL CONNECTOR, REMOTE	F(+24.0)	9	L	02	05	75			RECTIFIER & CONNECTOR PC CARD
B-REPR	4		P	17	01	05		COMMAND SWITCHES, LOCAL			L	02	15	01			FUSE, +24.0 V
			WT	20	08	08A		IC DECODER PC CARD	F(- 5.8)	6	L	02	05	85			RECTIFIER & CONNECTOR PC CARD
			L	22	22	04		MODE CONTROL CONNECTOR, REMOTE			L	02	13	01			FUSE, - 5.8 V
B-REW	2		P	17	01	07		COMMAND SWITCHES, LOCAL	F-LINE2	8	L	01	04	02			MAIN FUSE, TAPE DECK
			WT	20	05	17		SPOOLING MOTOR CONTROL PC CARD			F	01	03	03			POWER FEED CONNECTOR MAINS
			WT	20	08	12A	#	IC DECODER PC CARD			M	02	01	03			POWER INPUT FEED CONNECTOR
			L	22	22	02		MODE CONTROL CONNECTOR, REMOTE			F	02	08	02			POWER SWITCH FEED, RECEPTACLE
B-STOP	0		L	02	05	02		RECTIFIER & CONNECTOR PC CARD			M	03	01	02			EXTENSION CABLE, SUPPLY SIDE
			P	17	01	04		COMMAND SWITCHES, LOCAL			F	03	02	02			EXTENSION CABLE, SWITCH SIDE
			WTL	20	01	08		POWER CONNECTOR PC CARD			M	05	01	02			POWER SWITCH FEED, JACK
			WT	20	08	12B		IC DECODER PC CARD			L	05	03	01			POWER SWITCH, FRONT
			WT	20	11	18		ZERO LOCATOR PC CARD	F-M1	4	L	02	05	10			RECTIFIER & CONNECTOR PC CARD
			L	22													

SIG.NAME	COLOR	TYPE	GR	EL	PT	S	DESCRIPTION OF ELEMENT	SIG.NAME	COLOR	TYPE	GR	EL	PT	S	DESCRIPTION OF ELEMENT
F-M3	5	L	02 05 15				RECTIFIER & CONNECTOR PC CARD	(CONT.)	L	02 02 02					CHANNEL FEED CONNECTOR
		WTL	20 01 12				POWER CONNECTOR PC CARD		L	02 21 02					FEED CONNECTOR, SYNCHRONIZ. DPT.
		WT	20 06 17B				CAPSTAN SERVO PC CARD								
F-M3(0)	8	L	02 05 68				RECTIFIER & CONNECTOR PC CARD	K-TT	9	M	12 01 04				TAPE TENSION CONTROL ASSY, RIGHT
		L	02 12 01				FUSE, CAPSTAN		WT	20 08 22A					IC DECODER PC CARD
FAD-1	8	WT	20 10 15A				ATTENUATOR & PREAMP. PC CARD	K-TT1/2	7	M	11 01 04				TAPE TENSION CONTROL ASSY, LEFT
		L	22 22 11				MODE CONTROL CONNECTOR, REMOTE		M	12 01 05					IC DECODER PC CARD
FAD-2	9	WT	20 10 13A				ATTENUATOR & PREAMP. PC CARD	LINE1	5	Z	01 05 01*				MAINS FILTER
		L	22 22 29				MODE CONTROL CONNECTOR, REMOTE		F	01 03 01					POWER FEED CONNECTOR, MAINS
FL-LINE1	6	Z	01 05 01				MAINS FILTER		M	02 01 01					POWER INPUT FEED CONNECTOR
		L	01 09 01				POWER INPUT CONNECTOR		F	02 08 01					POWER SWITCH FEED, RECEPTACLE
FL-LINE2	7	Z	01 05 02				MAINS FILTER		M	03 01 01					EXTENSION CABLE, SUPPLY SIDE
		L	01 09 02				POWER INPUT CONNECTOR		F	03 02 01					EXTENSION CABLE, SWITCH SIDE
GND MAIN	4/5	L	01 09 03				POWER INPUT CONNECTOR		M	05 01 01					POWER SWITCH FEED, JACK
GROUND	4/5	L	01 02 01				GROUND POST, EXTERNAL		L	05 02 01					POWER SWITCH, REAR
		K	01 05 03				MAINS FILTER	LINE2	7	L	01 04 01				MAIN FUSE, TAPE DECK
		F	01 08 05				POWER FEED CONNECTOR, MAINS		Z	01 05 02*					MAINS FILTER
		M	02 01 05				POWER INPUT FEED CONNECTOR	M1-1	1	F	07 01 01				SUPPLY MOTOR (M1)
		LS	02 06 01				GROUND CHASSIS CONNECTION		WT	20 04 12					CONTACTOR PC CARD
K-BRAKE		WT	20 04 15				CONTACTOR PC CARD	M1-2	4	L	04 06 01				SUPPLY MOTOR CAPACITOR, ADD.
		WT	20 08 18B				IC DECODER PC CARD		F	07 01 03					SUPPLY MOTOR (M1)
K-CUT	5	M	15 01 04				PRESSURE ROLLER ASSEMBLY		WT	20 04 10					CONTACTOR PC CARD
		WT	20 08 08B				IC DECODER PC CARD	M2-1	6	F	10 01 01				TAKE-UP MOTOR (M2)
K-DIR		WT	20 04 16				CONTACTOR PC CARD		WT	20 04 08					CONTACTOR PC CARD
		WT	20 08 20A				IC DECODER PC CARD	M2-2	7	L	04 01 01				TAKE-UP MOTOR CAPACITOR, ADD.
K-FAD-1	8	P	17 01 15				COMMAND SWITCHES, LOCAL		L	04 13 01					TAKE-UP MOTOR CAPACITOR, MAIN
		WT	20 10 21B				ATTENUATOR & PREAMP. PC CARD		F	10 01 05					TAKE-UP MOTOR (M2)
K-LIFT	3	F	08 01 02				BRAKE LIFT SOLENOID, LEFT		WT	20 04 06					CONTACTOR PC CARD
		F	09 01 02				BRAKE LIFT SOLENOID, RIGHT	M3-1	6	M	16 01 01				CAPSTAN MOTOR ASSEMBLY
		WT	20 05 14				SPOOLING MOTOR CONTROL PC CARD		WT	20 06 13B					CAPSTAN SERVO PC CARD
		WT	20 08 20B				IC DECODER PC CARD	M4-1	3	P	18 01 05				TIMER FEED PC-CARD PLUG
		G	23 23 03				FEED TO TIME ELAPSE METER		WT	20 09 22A					IC MEMORY & COUNTER PC CARD
K-PRESS	0	L	02 05 04				RECTIFIER & CONNECTOR PC CARD		L	22 22 34					MODE CONTROL CONNECTOR, REMOTE
		M	15 01 02				PRESSURE ROLLER ASSEMBLY	M4-2	4	P	18 01 06				TIMER FEED PC-CARD PLUG
		WTL	20 01 06				POWER CONNECTOR PC CARD		WT	20 09 22B					IC MEMORY & COUNTER PC CARD
		WT	20 08 15A				IC DECODER PC CARD		L	22 22 16					MODE CONTROL CONNECTOR, REMOTE
		WT	20 10 07A				ATTENUATOR & PREAMP. PC CARD	M4-3	5	P	18 01 07				TIMER FEED PC-CARD PLUG
K-RESET	1	P	18 01 03				TIMER FEED PC-CARD PLUG		WT	20 09 15B					IC MEMORY & COUNTER PC CARD
		WT +	20 09 20A				IC MEMORY & COUNTER PC CARD		L	22 22 35					MODE CONTROL CONNECTOR, REMOTE
		L	22 22 33				MODE CONTROL CONNECTOR, REMOTE	M4-4	6	P	18 01 08				TIMER FEED PC-CARD PLUS
K-STOP	0	Y	02 05 33				* RECTIFIER & CONNECTOR PC CARD		WT	20 09 16A					IC MEMORY & COUNTER PC CARD
									L	22 22 17					MODE CONTROL CONNECTOR, REMOTE

SIG.NAME	COLOR	TYPE	GR	EL	PT	S	DESCRIPTION OF ELEMENT	SIG.NAME	COLOR	TYPE	GR	EL	PT	S	DESCRIPTION OF ELEMENT
M5-1	9	Y	02 05 68				N RECTIFIER & CONNECTOR PC CARD	(CONT.)	WT	20 02 23					+24/+20/+6/-6V STABIL. PC CARD
M5-2	9	Y	02 05 70				N RECTIFIER & CONNECTOR PC CARD	QPWR5-3	9	L	04 09 03				+ 5.8 V STABILIZER TRANSISTOR
Q-MOVE		WT	20 08 04B				IC DECODER PC CARD		WT	20 02 22					+24/+20/+6/-6V STABIL. PC CARD
		WT	20 10 05B				ATTENUATOR & PREAMP. PC CARD	QPWR6-2	5	H	04 08 02				+20.0 V STABILIZER TRANSISTOR
QP-DIR1	8	P	14 02 05				TAPE DIRECTION SENSOR		WT	20 02 03					+24/+20/+6/-6V STABIL. PC CARD
		WT	20 09 12B				IC MEMORY & COUNTER PC CARD	QPWR7-2	1	H	04 04 02				+24.0 V STABILIZER TRANSISTOR
QP-DIR2	7	P	14 02 03				TAPE DIRECTION SENSOR		WT	20 02 07					+24/+20/+6/-6V STABIL. PC CARD
		WT	20 09 13B				IC MEMORY & COUNTER PC CARD		WT	20 02 08					+24/+20/+6/-6V STABIL. PC CARD
QP-MOVE	4	P	14 01 03				TAPE MOVE SENSOR	R-CUT-1	5	M	19 01 01				CUTTER CONTROL ASSEMBLY
		WT	20 10 03B				ATTENUATOR & PREAMP. PC CARD		WT	20 05 15					SPOOLING MOTOR CONTROL PC CARD
QPWR1-1	2	L	04 12 01				SUPPLY MOTOR TRANSISTOR PAIR	R-CUT-3	7	F	19 01 03				CUTTER CONTROL ASSEMBLY
		WT	20 05 22				SPOOLING MOTOR CONTROL PC CARD		WT	20 05 13					SPOOLING MOTOR CONTROL PC CARD
QPWR1-2	5	L	04 12 02				SUPPLY MOTOR TRANSISTOR PAIR	R-TT1	1	M	11 01 02				TAPE TENSION CONTROL ASSY, LEFT
		WT	20 05 21				SPOOLING MOTOR CONTROL PC CARD		WT	20 05 16					SPOOLING MOTOR CONTROL PC CARD
QPWR1-3	8	L	04 12 03				SUPPLY MOTOR TRANSISTOR PAIR	R-TT2	2	M	12 01 02				TAPE TENSION CONTROL ASSY, RIGHT
		WT	20 05 20				SPOOLING MOTOR CONTROL PC CARD		WT	20 04 18					CONTACTOR PC CARD
QPWR2-1	1	L	04 05 01				TAKE-UP MOTOR TRANSISTOR PAIR		WT	20 05 09					SPOOLING MOTOR CONTROL PC CARD
		WT	20 05 03				SPOOLING MOTOR CONTROL PC CARD	REM-IN	7	P	17 01 14				COMMAND SWITCHES, LOCAL
QPWR2-2	4	L	04 05 02				TAKE-UP MOTOR TRANSISTOR PAIR		WT +	20 10 09A					ATTENUATOR & PREAMP. PC CARD
		WT	20 05 04				SPOOLING MOTOR CONTROL PC CARD		L	22 22 19					MODE CONTROL CONNECTOR, REMOTE
QPWR2-3	9	L	04 05 03				TAKE-UP MOTOR TRANSISTOR PAIR	RP-END	8	M	13 01 03				OPTICAL TAPE END SENSOR
		WT	20 05 08				SPOOLING MOTOR CONTROL PC CARD		WT	20 10 04B					ATTENUATOR & PREAMP. PC CARD
QPWR3-1	4	H	04 11 01				CAPSTAN MOTOR CONTROL TRANSISTOR	S-CUT	6	P	17 01 13				COMMAND SWITCHES, LOCAL
		WT	20 06 22B				CAPSTAN SERVO PC CARD		WT	20 10 10B					ATTENUATOR & PREAMP. PC CARD
QPWR3-2	9	H	04 11 02				CAPSTAN MOTOR CONTROL TRANSISTOR		L	22 22 25					MODE CONTROL CONNECTOR, REMOTE
		WT	20 06 21B				CAPSTAN SERVO PC CARD	S-CUTAUT	1	M	19 01 04				CUTTER CONTROL ASSEMBLY
QPWR3-3	7	L	04 11 03				CAPSTAN MOTOR CONTROL TRANSISTOR		WT	20 08 21B					IC DECODER PC CARD
		WT	20 06 20B				CAPSTAN SERVO PC CARD	S-FORW	3	P	17 01 10				COMMAND SWITCHES, LOCAL
QPWR4-1	1	H	04 10 01				- 5.8 V STABILIZER TRANSISTOR		WT	20 10 15B *					ATTENUATOR & PREAMP. PC CARD
		WT	20 02 17				+24/+20/+6/-6V STABIL. PC CARD		WT	20 11 14					ZERO LOCATOR PC CARD
QPWR4-2	8	H	04 10 02				- 5.8 V STABILIZER TRANSISTOR		L	22 22 21					MODE CONTROL CONNECTOR, REMOTE
		WT	20 02 16				+24/+20/+6/-6V STABIL. PC CARD	S-HI	4	Y	02 05 32				* RECTIFIER & CONNECTOR PC CARD
QPWR4-3	6	L	04 10 03				- 5.8 V STABILIZER TRANSISTOR		L	02 20 04					CHANNEL FEED CONNECTOR
		WT	20 02 15				+24/+20/+6/-6V STABIL. PC CARD		L	02 21 04					FEED CONNECTOR, SYNCHRONIZ. DPT.
QPWR5-1	5	H	04 09 01				+ 5.8 V STABILIZER TRANSISTOR	S-HIGH	4	L	02 05 07				* RECTIFIER & CONNECTOR PC CARD
		WT	20 02 24				+24/+20/+6/-6V STABIL. PC CARD		L	05 04 03					TAPE SPEED SELECTOR SWITCH
QPWR5-2	7	H	04 09 02				+ 5.8 V STABILIZER TRANSISTOR		F	05 05 03					SPEED SELECTOR FEED, JACK
									M	06 01 03					SPEED SELECTOR, CABLE PLUS
									WTL	20 01 03					POWER CONNECTOR PC CARD
									WT	20 02 13					+24/+20/+6/-6V STABIL. PC CARD
									WT	20 11 11					ZERO LOCATOR PC CARD
									L	22 22 27					MODE CONTROL CONNECTOR, REMOTE

SIG.NAME	COLOR	TYPE	GR	EL	PT	S	DESCRIPTION OF ELEMENT	SIG.NAME	COLOR	TYPE	GR	EL	PT	S	DESCRIPTION OF ELEMENT
(CONT.)		WT	20	09	03A		IC MEMDRY & COUNTER PC CARD	(CONT.)		WT	20	11	15		ZERO LOCATOR PC CARD
		WT	20	10	06B		ATTENUATOR & PREAMP. PC CARD			N	18	02	06		TIMER FEED 11-POLE CIS PLUS
YBI-FAD		WT	20	09	11B		IC MEMORY & COUNTER PC CARD			WT	20	11	19		ZERO LOCATOR PC CARD
		WT	20	10	20B		ATTENUATOR & PREAMP. PC CARD								
YBI-FF0		WT	20	08	06B		IC DECODER PC CARD								
		WT	20	09	07B		IC MEMORY & COUNTER PC CARD								
YBI-FF1		WT	20	08	10B		IC DECODER PC CARD								
		WT	20	09	05A		IC MEMDRY & COUNTER PC CARD								
YBI-FF2		WT	20	08	07B		IC DECODER PC CARD								
		WT	20	09	08B		IC MEMORY & COUNTER PC CARD								
YBI-FF3		WT	20	08	09B		IC DECODER PC CARD								
		WT	20	09	09B		IC MEMORY & COUNTER PC CARD								
YBI-FF4		WT	20	08	11B		IC DECODER PC CARD								
		WT	20	09	10B		IC MEMORY & COUNTER PC CARD								
YBI-LOW		WT	20	09	21B		IC MEMORY & COUNTER PC CARD								
		WT	20	10	21A		ATTENUATOR & PREAMP. PC CARD								
YBI-MOVE		WT	20	05	11		SPOOLING MOTOR CONTROL PC CARD								
		WT	20	08	03B		IC DECODER PC CARD								
		WT	20	09	05B		IC MEMORY & COUNTER PC CARD								
YBI-MOV2		WT	20	09	06B	N	IC MEMORY & COUNTER PC CARD								
YBI-REC		WT	20	08	22B		IC DECODER PC CARD								
		WT	20	10	06A		ATTENUATOR & PREAMP. PC CARD								
YPS-CUT		WT	20	09	10A		IC MEMORY & COUNTER PC CARD								
		WT	20	10	19B		ATTENUATOR & PREAMP. PC CARD								
YPS-FORW		WT	20	09	08A		IC MEMORY & COUNTER PC CARD								
		WT	20	10	14B		ATTENUATOR & PREAMP. PC CARD								
YPS-MOVE 7		WT	20	10	16A	*	ATTENUATOR & PREAMP. PC CARD								
		WT	20	11	12		ZERO LOCATOR PC CARD								
		L	22	22	09		MODE CONTROL CONNECTOR, REMOTE								
YPS-REC		WT	20	09	04A		IC MEMORY & COUNTER PC CARD								
		WT	20	10	08B		ATTENUATOR & PREAMP. PC CARD								
YPS-REPR		WT	20	09	07A		IC MEMORY & COUNTER PC CARD								
		WT	20	10	12B		ATTENUATOR & PREAMP. PC CARD								
YPS-REW		WT	20	09	09A		IC MEMORY & COUNTER PC CARD								
		WT	20	10	16B		ATTENUATOR & PREAMP. PC CARD								
YPS-STOP		WT	20	09	06A		IC MEMORY & COUNTER PC CARD								
		WT	20	10	17A		ATTENUATOR & PREAMP. PC CARD								
Y2-SIGN 9		N	18	02	01		TIMER FEED 11-POLE CIS PLUG								

DESCRIPTION OF ELEMENT	GR	EL	PT
TIMER FEED 11-POLE CIS PLUG	18	02	11K
+24/+20/+6/-6V STABIL. PC CARD	20	02	22K
CONTACTOR PC CARD	20	04	06K
SPOOLING MOTOR CNTRDL PC CARD	20	05	12K
CAPSTAN SERVO PC CARD	20	06	02K
IC DECODER PC CARD	20	08	10K
IC MEMDRY & COUNTER PC CARD	20	09	20K
ATTENUATOR & PREAMP. PC CARD	20	10	16K
ZERO LOCATOR PC CARD	20	11	19K

FROM GROUP	TO GROUP	WIRES	FROM GROUP	TO GROUP	WIRES	FROM GROUP	TO GROUP	WIRES	FROM GROUP	TO GROUP	WIRES
I 1	1	7	I 1	2	3	I			I		
I 2	2	81	I 2	3	4	I 2	20	10	I		
I 3	3	4	I 3	5	4	I			I		
I 4	4	4	I 4	20	26	I			I		
I 5	5	7	I 5	6	2	I 5	20	1	I		
I 6	20	2	I			I			I		
I 7	20	3	I			I			I		
I 8	20	1	I			I			I		
I 9	20	1	I			I			I		
I 10	20	3	I			I			I		
I 11	20	3	I			I			I		
I 12	20	3	I			I			I		
I 13	20	4	I			I			I		
I 14	20	7	I			I			I		
I 15	20	4	I			I			I		
I 16	20	7	I			I			I		
I 17	20	14	I			I			I		
I 18	20	15	I			I			I		
I 19	20	4	I			I			I		
I 20	20	122	I 20	21	5	I 20	22	26	I		

TOTAL WIRES: 377

5. VERSTÄRKER-EINSTELLUNGEN

Voraussetzung für die folgenden Einstellungen ist, dass das Laufwerk korrekt eingestellt ist. Ist dies nicht der Fall, können die Verstärker nicht korrekt eingestellt werden.

5.1 ALLGEMEINES

5.1.1 Erläuterungen

Das Prüfprotokoll gibt an, für welche Bandsorte und für welche Leitungspegel das Gerät eingestellt ist. Dabei sind die Pegelverhältnisse grundsätzlich auf CCIR- oder NAB-Messband bezogen.

Die Unterschiede dieser Normen sind unbedingt zu beachten. Eine Gegenüberstellung der Bezugspegel zeigt folgende wichtige Unterschiede:

NAB

Bezugspegel (operating level) entspricht 0 VU. Dieser Pegel liegt 6 dB unter Vollaussteuerung (peak recording level).
Magnetisierung (Bandfluss):
Bezugspegel (operating level) 200 nWb/m
Vollaussteuerung (peak recording level) 400 nWb/m

CCIR

Bezugspegel entspricht Vollaussteuerung.
Magnetisierung (Bandfluss):
Bezugspegel (Vollspur, Zweispur) 320 nWb/m
(Stereo, 2,75 mm Spurbreite) 510 nWb/m

Zum besseren Verständnis der Kontrollen und Einstellmethoden an den Verstärker-Einheiten sind deren Konzeptionsmerkmale nachfolgend erläutert.

5. AMPLIFIER ADJUSTMENTS

As a prerequisite for the following adjustments, the tape transport system must have been calibrated correctly. If this is not the case, the amplifiers cannot be adjusted correctly.

5.1 GENERAL

5.1.1 Definitions

The test protocol indicates the type of tape with which the unit has been calibrated. The various levels are based on CCIR or NAB test tapes.

It is important to recognize the difference between these two standards. The following comparison exemplifies the major differences:

NAB

Reference level (operating level) corresponds to 0 VU. This level is reached at 6 dB below peak recording level).
Magnetizing force (tape flux):
Operating level 200 nWb/m
Peak recording level 400 nWb/m

CCIR

Reference level equals peak recording level.
Magnetizing force (tape flux):
Operating level (full track, two-track) 320 nWb/m
(Stereo 2.75 mm track width) 510 nWb/m

To clarify the functions of the controls and adjustments for the amplifier units the design features will briefly be explained.

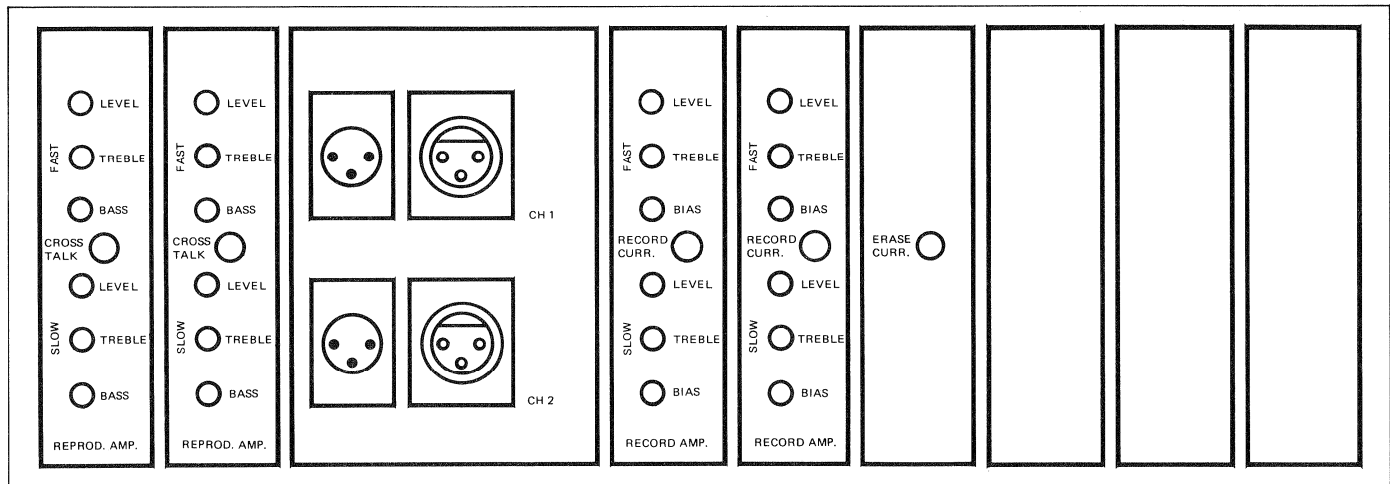

Fig. 5.1

– Der Verstärkerkorb enthält folgende Einschübe:

– The amplifier section comprises the following plug-in circuits:

A80 R

Wiedergabe-Verstärker
(REPROD AMP)

Anschlussfeld

Stabilisatorsteckkarte
(hinter dem Anschlussfeld)

Aufnahme-Verstärker
(RECORD AMP)

Oszillator

Pilotton-Verstärker
(fakultativ)
Gerät vorbereitet

A80 RT und A80 RTQ

Wiedergabe-Verstärker
(REPROD AMP)

Aufnahme-Verstärker
(RECORD AMP)

Oszillator

Stabilisator (RECORD)

Stabilisator (REPRODUCE)

A80 R

Reproduce amplifier
(REPROD AMP)

Connection panel

Stabilizer PCB (behind connection panel)

Record amplifier
(RECORD AMP)

Oscillator

Pilot tone amplifier (optional)
Equipment ready

A80 RT and A80 RTQ

Reproduce amplifier
(REPROD AMP)

Record amplifier
(RECORD AMP)

Oscillator

Stabilizer (RECORD)

Stabilizer (REPRODUCE)

Die Leitungs-Eingänge und -Ausgänge sind an der Rückseite des Gerätes plaziert.

The input and output wiring are located at the rear of the unit.

– Die Aufnahme- und Wiedergabe-Verstärker sind in separaten Kanaleinschüben untergebracht. Auf den Kanaleinschüben RECORD AMP und REPRODUCE AMP sind die entsprechenden Abgleichregler für Aufnahme und Wiedergabe zusammengefasst.

– The record and reproduce amplifiers are mounted on separate plug-in modules. The modules RECORD AMP and REPRODUCE AMP contain the corresponding balancing potentiometers for record and playback.

Im oberen Teil des Einschubes erfolgen die Einstellungen für die hohe Bandgeschwindigkeit, im unteren Teil für die niedrige Bandgeschwindigkeit.

The adjustments for high tape speed are performed in the upper section of the plug-in module, the low-speed adjustments in the lower section.

- Die Einschübe sind verriegelt; zum entriegeln sind die beiden randrierten Befestigungsknöpfe im Gegenuhrzeigersinn um 90° zu drehen.

- The plug-in modules are locked in place. To unlock, turn the two knurled knobs 90° in counter-clockwise direction.

Der Einschub kann nun herausgezogen werden.

Now, the board will slide out easily.

Achtung:

- VOR DEM AUSWECHSELN DER EINSCHÜBE GERÄT AUSSCHALTEN.
- Vor Kontrollen und Einstellungen an den Verstärkern sind die Tonköpfe und Bandführungen sorgfältig zu reinigen und zu entmagnetisieren.

Caution:

- THE MACHINE MUST BE SWITCHED OFF BEFORE EXCHANGING PLUG IN MODULES.
- Carefully clean and demagnetize the heads and tape guides before checking and adjusting amplifiers.

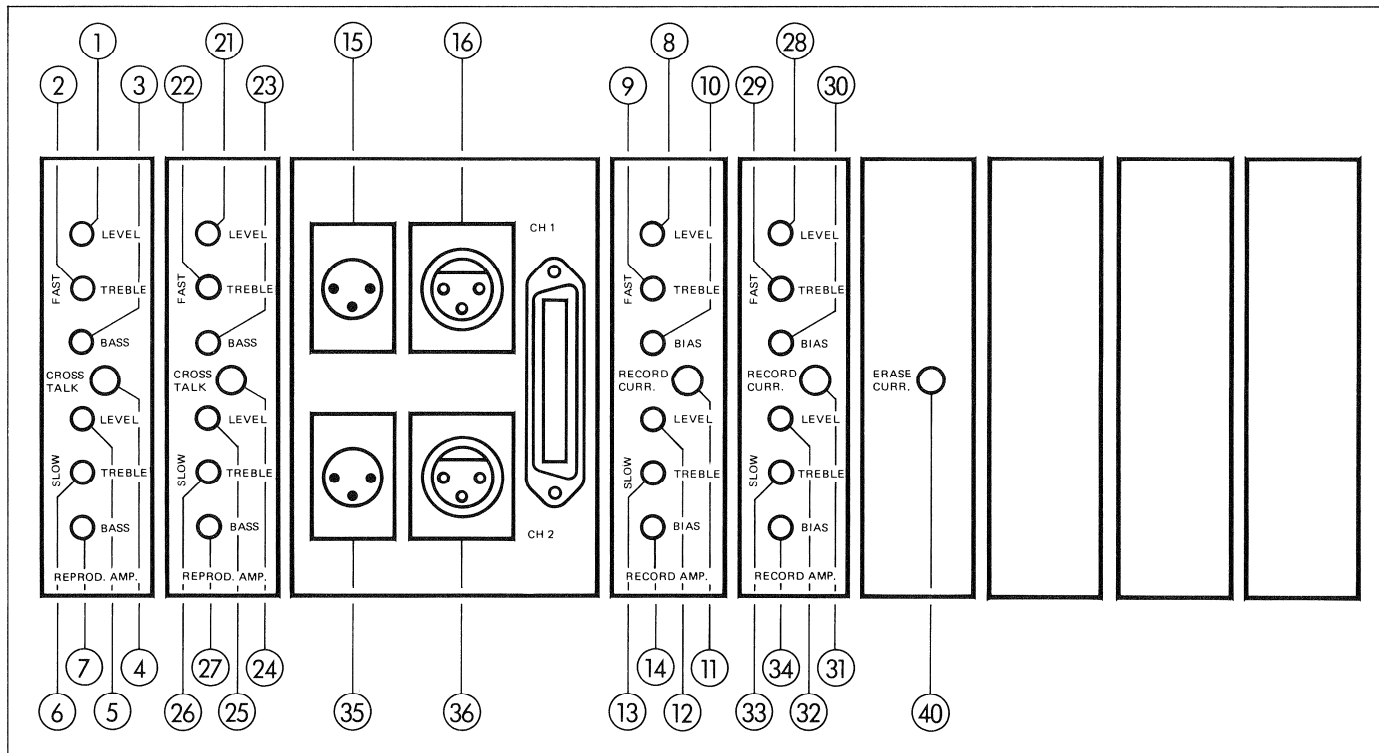

Fig. 5.2

5.1.2 Bezeichnungen und Anschlüsse

Kanal 1 (CH I)

Wiedergabeverstärker	(REPROD AMP)
(1) Pegelregler	LEVEL/FAST ¹
(2) Höhenregler	TREBLE/FAST ¹
(3) Tiefenregler	BASS/FAST ¹

5.1.2 Descriptions and connections

Channel 1 (CH I)

Reproduce amplifier	(REPROD AMP)
(1) Level control	LEVEL/FAST ¹
(2) Treble control	TREBLE/FAST ¹
(3) Bass control	BASS/FAST ¹

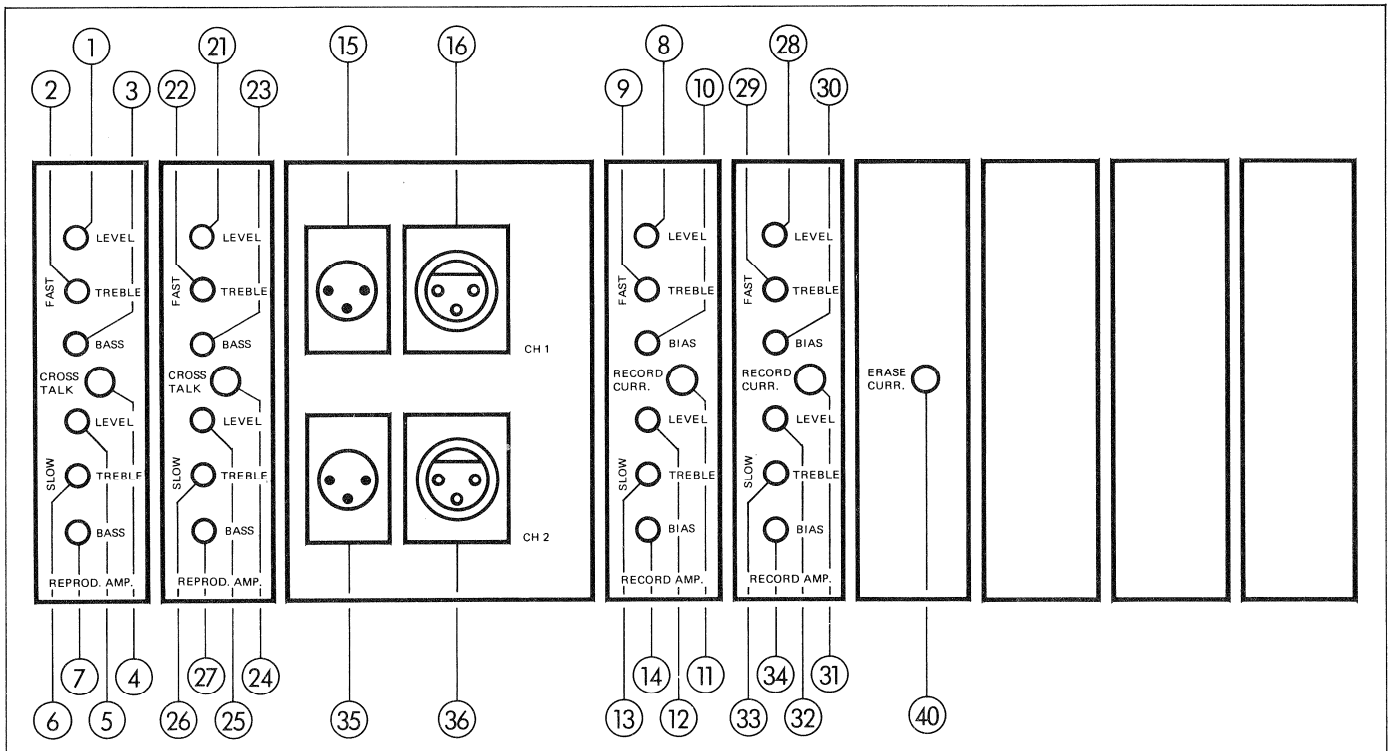

Fig. 5.3

(4) Übersprech-Regler	CROSSTALK	(4) Crosstalk control	CROSSTALK
(5) Pegelregler	LEVEL/SLOW ²	(5) Level control	LEVEL/SLOW ²
(6) Höhenregler	TREBLE/SLOW ²	(6) Treble control	TREBLE/SLOW ²
(7) Tiefenregler	BASS/SLOW ²	(7) Bass control	BASS/SLOW ²
Aufnahmeverstärker	(RECORD AMP)	Record amplifier	
(8) Pegelregler	LEVEL/FAST ¹	(8) Level control	LEVEL/FAST ¹
(9) Höhenregler	TREBLE/FAST ¹	(9) Treble control	TREBLE/FAST ¹
(10) Vormagnetisierungs-Regler	BIAS/FAST ¹	(10) Bias control	BIAS/FAST ¹
(11) Anschluss für Aufnahmestrommessung	RECORD CURR	(11) Connector for record current measurement	RECORD CURR
(12) Pegelregler	LEVEL/SLOW ²	(12) Level control	LEVEL/SLOW ²
(13) Höhenregler	TREBLE/SLOW ²	(13) Treble control	TREBLE/SLOW ²
(14) Vormagnetisierungs-Regler	BIAS/SLOW ²	(14) Bias control	BIAS/SLOW ²
Anschlussfeld		Connection panel	
(15) Leitungs-Eingang CH I		(15) Line input CH I	
(16) Leitungs-Ausgang (CH I)		(16) Line output CH I	

1 = hohe Bandgeschwindigkeit
high tape speed

2 = niedere Bandgeschwindigkeit
low tape speed

Kanal 2 (CH II)**Channel 2 (CH II)**

Wiedergabeverstärker	(REPROD AMP)	Reproduce amplifier	(REPROD AMP)
(21) Pegelregler	LEVEL/FAST ¹	(21) Level control	LEVEL/FAST ¹
(22) Höhenregler	TREBLE/FAST ¹	(22) Treble control	TREBLE/FAST ¹
(23) Tiefenregler	BASS/FAST ¹	(23) Bass control	BASS/FAST ¹
(24) Übersprech-Regler	CROSSTALK	(24) Crosstalk control	CROSSTALK
(25) Pegelregler	LEVEL/SLOW ²	(25) Level control	LEVEL/SLOW ²
(26) Höhenregler	TREBLE/SLOW ²	(26) Treble control	TREBLE/SLOW ²
(27) Tiefenregler	BASS/SLOW ²	(27) Bass control	BASS/SLOW ²
Aufnahmeverstärker	(RECORD AMP)	Record amplifier	
(28) Pegelregler	LEVEL/FAST ¹	(28) Level control	LEVEL/FAST ¹
(29) Höhenregler	TREBLE/FAST ¹	(29) Treble control	TREBLE/FAST ¹
(30) Vormagnetisierungsregler	BIAS/FAST ¹	(30) Bias control	BIAS/FAST ¹
(31) Anschluss für Aufnahmestrommessung	RECORD CURR	(31) Connector for record current measurement	RECORD CURR
(32) Pegelregler	LEVEL/SLOW ²	(32) Level control	LEVEL/SLOW ²
(33) Höhenregler	TREBLE/SLOW ²	(33) Treble control	TREBLE/SLOW ²
(34) Vormagnetisierungsregler	BIAS/SLOW ²	(34) Bias control	BIAS/SLOW ²
Anschlussfeld	(CCIR)	Connection panel	(CCIR)
(35) Leitungs-Eingang CH II		(35) Line input CH II	
(36) Leitungs-Ausgang CH II		(36) Line output (CH II)	
Oszillator		Oscillator	
(40) Anschluss für Löschstrom-Messung	ERASE CURR	(40) Connection for measuring erase current	ERASE CURR

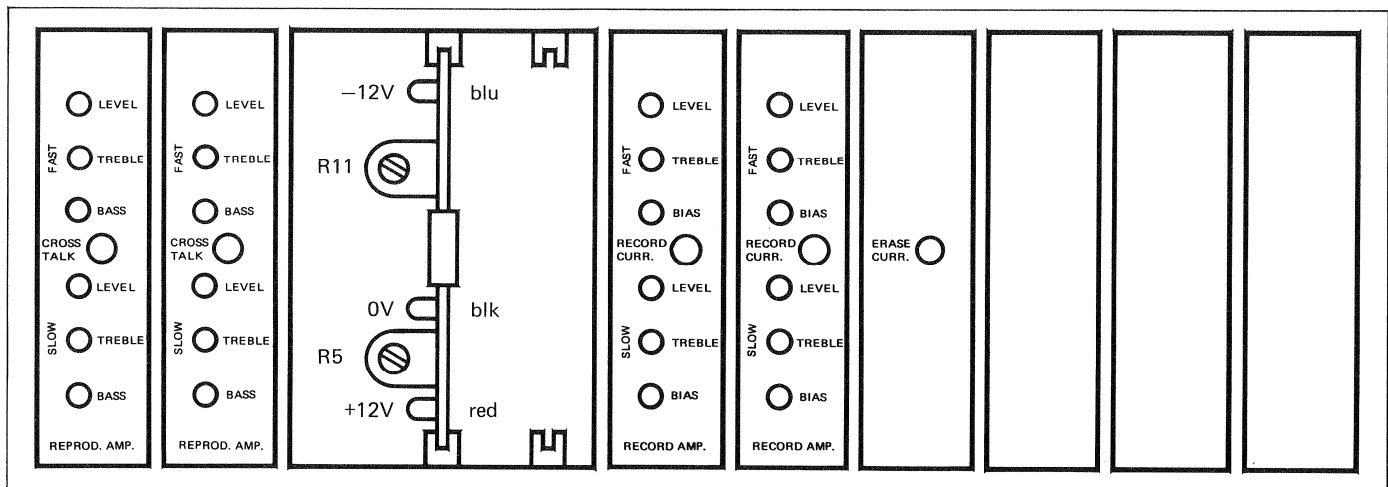

Fig. 5.4

5.1.3 Messgeräte und Einstellwerkzeug

Voltmeter (DC)	
Tonfrequenz-Millivoltmeter (Klirrfaktor $\leq 0,5\%$).	
Tonfrequenz-Millivoltmeter (Frequenzbereich wenn möglich bis max. 20 kHz).	
Messbänder gemäss CCIR (DIN) oder NAB	
2-Kanal-Kathodenstrahl-Oszillograph (wird für MONO-Geräte nicht benötigt)	
Digital-Frequenzzähler	
Frequenz-Analysator (nur für Übersprech-Einstellung erforderlich)	
Kopfmagnetisierungs-Drossel oder ähnliches	1.337.945
Verlängerungssteckkarte für Verstärker	1.080.940

5.2 EINSTELLEN DER +12 V/–12 V SPEISUNGEN DER VERSTÄRKER

Die Speisungen + 12 V/–12 V befinden sich auf der Stabilisatorsteckkarte 1.080.988, welche hinter dem Anschlussfeld positioniert ist. Demzufolge muss das Anschlussfeld ausgezogen werden.

Einstellen:

- Anschlussfeld herausziehen
- Voltmeter DC an die Testpunkte 0 V (blk) und + 12 V (red) anschliessen
- Mit Potentiometer R5 auf + 12 V $\pm 0,2$ V einstellen
- Voltmeter DC an die Testpunkte 0 V (blk) und –12 V (blu) anschliessen
- Mit Potentiometer R11 auf –12 V $\pm 0,2$ V einstellen

5.1.3 Measuring instruments and adjustment tools

Voltmeter (DC)	
Audio-frequency millivoltmeter (harmonic distortion $\approx 0.5\%$)	
Audio-frequency millivoltmeter (frequency range max. 20 kHz if possible)	
Test tapes according to CCIR (DIN) or NAB	
Two-channel cathode ray oscilloscope (not required for mono units)	
Digital frequency counter	
Frequency analyzer (only required for crosstalk adjustment)	
Head demagnetizer coil or similar	1.337.945
Extension board for amplifier	1.080.940

5.2 ADJUSTMENT OF +12 V/–12 V AMPLIFIER SUPPLY VOLTAGE

The supply voltage + 12 V/–12 V are located on the stabilizer circuit board 1.080.988 which is located at the rear connection panel. This requires that the connection panel be pulled out.

Adjustments

- Pull out connection panel
- Attach DC voltmeter to test point 0 V (blk.) and + 12 V (red).
- Adjust R5 potentiometer to + 12 V ± 0.2 V
- Connect DC voltmeter to test points 0 V (blk.) and –12 V (blu.)
- Adjust R11 potentiometer to –12 V ± 0.2 V

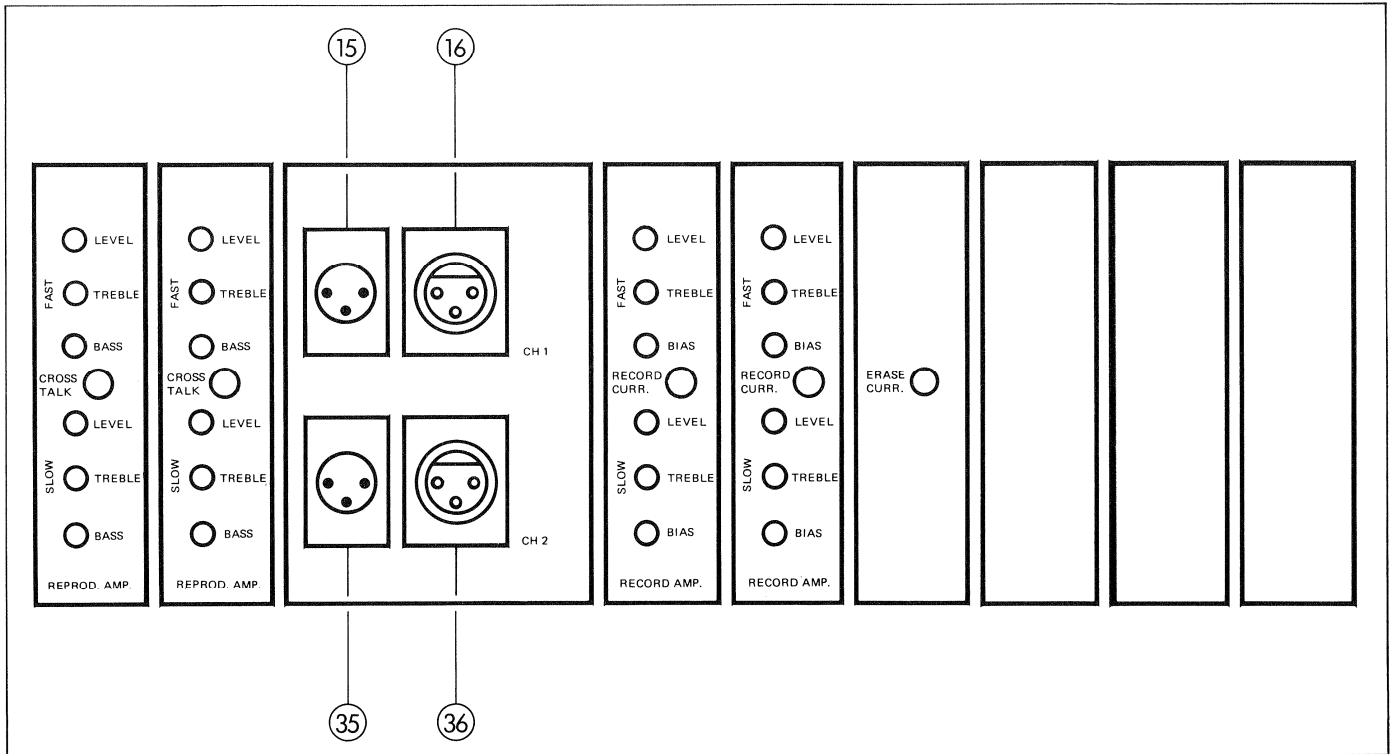

Fig. 5.5

5.3 WIEDERGABEEINSTELLUNGEN

Die Tonköpfe und die Bandführungselemente sorgfältig reinigen und entmagnetisieren (Kopfentmagnetisierungsdrossel Nr. 1.337.945)

Vor den Einstellungen sollten die Datenblätter der entsprechenden Testbänder aufmerksam durchgelesen werden (Pegel, Frequenzen, Bandfluss usw.).

Die Einschübe müssen kontrolliert werden, ob sie für die entsprechenden Normen und Geschwindigkeiten ausgerüstet sind.

Die Anschlüsse, welche in den folgenden Messungen gebraucht werden, sind in Europa-Norm gehalten.

Für die USA-Norm sind sie jeweils invers:

- Eingang CH I (15) wird (16)
- Ausgang CH I (16) wird (15)
- Eingang CH II (35) wird (36)
- Ausgang CH II (36) wird (35)

Bei allen Einstellungen müssen die Ausgänge mit 200 Ohm (CCIR) oder 600 Ohm (NAB) abgeschlossen sein.

5.3 PLAYBACK ADJUSTMENTS

Carefully clean heads and tape guides, then demagnetize with head demagnetizer coil No. 1.337.945.

Carefully read specification sheets of the corresponding test tapes (levels, frequencies, magnetization level, etc.) before starting with the adjustments.

Check whether plug-in modules are properly designed for the respective standards and speeds.

The connectors which need to be accessed in the following tests are implemented in Europa-Norm.

For US standards they are reversed:

- Input CH I (15) becomes (16)
- Output CH I (16) becomes (15)
- Input CH II (35) becomes (36)
- Output CH II (36) becomes (35)

The outputs must be terminated with 200 ohms (CCIR) or 600 ohms (NAB).

5.3.1**Pegeleinstellen der Wiedergabeverstärker**

(schnelle Bandgeschwindigkeit FAST)

1. Gerät auf schnelle Bandgeschwindigkeit schalten
2. Entsprechendes Messband auflegen.
3. Tonfrequenz-Millivoltmeter am Leitungsausgang Kanal 1 (16) (CH I) anschliessen. (Ausgang mit Leitungswiderstand von 200 bzw. 600 Ohm abschliessen.)
4. Messband auf Wiedergabe starten im Abschnitt "Bezugspegel 1000 Hz" (CCIR), bzw. "operating level 700 Hz" (NAB)
5. Regler LEVEL/FAST (1), Einschub REPROD AMP (CH I), auf den erforderlichen Leitungspegel einstellen.
6. Bei Zweikanalgeräten:
Pegeleinstellung für Kanal 2 (CH II) vornehmen, analog Positionen 1 bis 5.
Der zugehörige Anschluss und Regler ist: Leitungsausgang (36)
Regler LEVEL/FAST (21)

5.3.1**Level adjustment for reproduce amplifier (FAST)**

(fast tape speed FAST)

1. Switch machine to fast tape speed.
2. Mount appropriate test tape.
3. Connect audio-frequency millivoltmeter to output channel 1 (16) (CH I) (output terminated with line resistor 200 ohms or 600 ohms).
4. Play reference tape at section "Reference level 1000 Hz" (CCIR) or "Operating level 700 Hz" (NAB).
5. Adjust LEVEL/FAST (1) control contained on REPROD AMP (CH I) board to the required line level.
6. For two-channel units:
Repeat level adjustment for channel 2 (CH II) analogous to steps 1 to 5 above.
The associated connection point and controls are: line output (36)
LEVEL/FAST control (21)

5.3.2**Pegeleinstellen der Wiedergabeverstärker**

(langsame Bandgeschwindigkeit SLOW)

1. Gerät auf langsame Bandgeschwindigkeit schalten.
2. Entsprechendes Messband auflegen.
3. Tonfrequenz-Millivoltmeter am Leitungsausgang Kanal 1 (16) (CH I) anschliessen. (Ausgang mit Leitungswiderstand von 200 bzw. 600 Ohm abschliessen.)
4. Messband auf Wiedergabe starten im Abschnitt "Bezugspegel 1000 Hz" (CCIR) bzw. "operating level 700 Hz" (NAB)
5. Regler LEVEL/SLOW (5), Einschub REPROD AMP (CH I), auf den erforderlichen Leitungspegel einstellen.
6. Bei Zweikanalgeräten:
Pegeleinstellung für Kanal 2 (CH II) vornehmen, analog Positionen 1 bis 5.
Der zugehörige Anschluss und Regler ist: Leitungsausgang (36)
Regler LEVEL/SLOW (25)

5.3.2**Level adjustment for reproduce amplifier**

(tape speed SLOW)

1. Switch machine to slow running speed.
2. Mount corresponding test tape.
3. Connect audio-frequency millivoltmeter to output channel 1 (16) (CH I) (output terminated with line resistor 200 ohms or 600 ohms).
4. Play reference tape at section "Reference level 1000 Hz" (CCIR) or "Operating level 700 Hz" (NAB)
5. Adjust LEVEL/FAST (5) at plug-in module REPROD AMP (CH I) to the required line level.
6. For two-channel units:
Repeat level adjustment for channel 2 (CH II) analogous to positions 1 and 5 above
The associated connection point and controls are: line output (36)
LEVEL/FAST control (25)

5.3.3

Wiedergabekopf Spalteinstellung (AZIMUT)

A für Mono-Geräte

- Kopfträger demontieren und Zwischenberuhigungsrolle (Fig. 5.6) entfernen
- Kopfträger wieder montieren
- Gerät auf schnelle Bandgeschwindigkeit (FAST) schalten
- Entsprechendes Messband im Abschnitt "Spalteinstellung" auf Wiedergabe starten
- Tonfrequenzmillivoltmeter an Leitungsausgang (16) (CH I) anschliessen
- Mit Spaltjustierschraube (C) (Fig. 5.7) den Wiedergabekopf auf Pegelmaximum einstellen
- Bei massiver Justierung d.h. bei grober Abweichung des Pegels müssen die Einstellungen Kapitel 5.3.1 und 5.3.2 wiederholt werden
- Kopfträger demontieren und Zwischenberuhigungsrolle wieder einbauen
- Kopfträger wieder montieren
- Schnelle Bandgeschwindigkeit einschalten
- Festhalteschraube (A) (Fig. 5.6) der Zwischenberuhigungsrolle lösen
- Zwischenberuhigungsrolle taumeln (mit einem feinen Schraubendreher oder Rundstäbchen in Loch (B) Fig.5.6) bis das gleiche Pegelmaximum erreicht wird wie bei der Azimuteinstellung
- Festhalteschraube (A) sorgfältig festziehen.

Achtung:

Dabei darf sich der Ausgangspegel nicht verändern und das Band sollte nicht am rechten Bandführungsbolzen streifen.

5.3.4

Wiedergabekopf Spalteinstellung (AZIMUT)

B für Stereo oder 2-Spur Geräte

- Kopfträger demontieren und Zwischenberuhigungsrolle (Fig.5.6) ausbauen
- Kopfträger wieder montieren
- Gerät auf schnelle Bandgeschwindigkeit (FAST) schalten
- Tonfrequenzmillivoltmeter an Leitungsausgang CH I (16) oder CH II (36) anschliessen
- Mit dem entsprechenden Regler CH I (2) /CH II (22) (Einschübe REPROD AMP) auf identische Ausgangspegel einstellen (Vorabgleich = 0,5 dB)
- Wiedergabekopf mittels Spaltjustierschraube (C) Fig. 5.7 auf Pegelmaximum einstellen
- Wenn das Pegelmaximum bei weitem nicht erreicht wird, so ist die Voreinstellung zu wiederholen.

Bei Tonbandgeräten beeinflusst die Stellung der Kopfspaltwinkel zur Bandlaufrichtung nicht nur den Pegel der hohen Frequenzen, sondern auch die Phasenlage zwischen den Kanälen. Diese stellt ein wesentlich wichtigeres Kriterium zur Spaltjustierung dar, als die Einstellung nach Pegelmaximum.

5.3.3

Azimuth adjustment for reproduce head

A for mono units

- Remove head block assembly and intermediate stabilizer roller (Fig. 5.6)
- Re-install headblock assembly
- Set unit to fast tape speed (FAST)
- Wind corresponding reference tape to section "azimuth setting" and start in playback mode
- Connect audio-frequency millivoltmeter to line output (16) (CH I)
- Adjust reproducing head for maximum level by turning adjustment screw (C) (Fig. 5.7)
- For substantial adjustments (i.e. significant deviation from the level), the adjustments in chap. 5.3.1 and 5.3.2 must be repeated.
- Remove headblock assembly and re-install intermediate stabilizer roller
- Set machine to fast tape speed
- Loosen setscrew (A) (Fig. 5.6) of intermediate stabilizer roller
- Wobble intermediate stabilizer roller (with small screw driver or round pin in hole (B) (Fig. 5.6) until the same maximum level is reached as with azimuth adjustment setting
- Carefully retighten setscrew (A).

Caution:

The output level must not change and the tape should not touch the right-hand tape guide bolt.

5.3.4

Azimuth adjustment for reproduce head

B for stereo or two-track units

- Remove headblock assembly and intermediate stabilizer roller (Fig.5.6)
- Re-install headblock assembly
- Set unit to fast speed (FAST)
- Connect audio-frequency millivoltmeter to line output CH 1 (16) or CH II (36)
- Adjust CH I (2)/CH II (22) (plug-in modules REPROD AMP) for identical output levels (pre-equalization = 0.5 dB) at corresponding control.
- Adjust reproducing head for maximum level by turning azimuth adjustment screw (C) (Fig. 5.7).
- If the maximum level reached is considerably below the reference value, the presetting must be repeated.

The adjustment of the azimuth angle relative to the tape direction not only affects the level of high frequencies but also the phasing between the two channels. This criterion in azimuth adjustment is more important than the adjustment for maximum level.

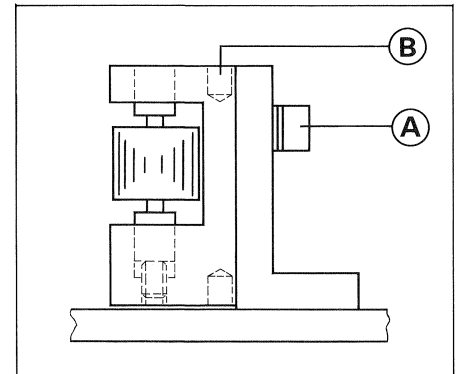

Fig. 5.6

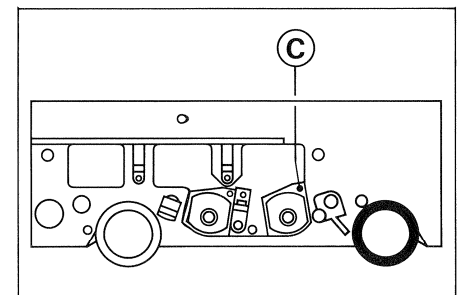

Fig. 5.7

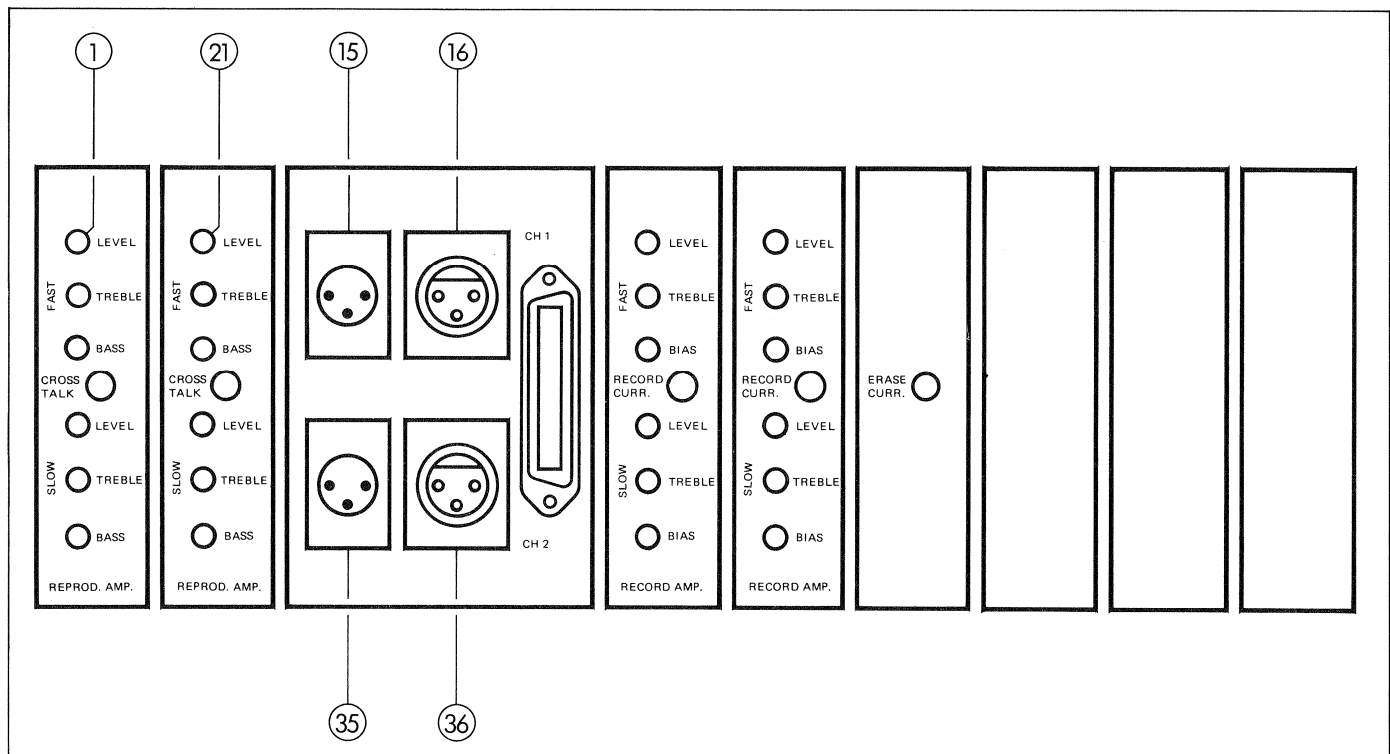

Fig. 5.8

Die Bestimmung des Phasenwinkels wird mit folgenden Pegelmessungen durchgeführt:

- A Messmethode mit Oszilloskop mit X und Y Eingängen
Lissajoux-Figuren
- B Messmethode mit 2-Kanal Oszilloskop
- C Phasenmeter (z.B. Studer Nr. 10.010.201-01)
- D Messmethode mit Summen- und Differenzpegel

Messmethode mit Summen- und Differenzpegel

Die Messung erfolgt beim Abspielen des für die Kopfeinstellung bestimmten Teils des Bezugsbandes, mit Hilfe der Ausgangspegel der Kanäle 1 und 2.

Zunächst wird kontrolliert, ob die Pegel der beiden Kanäle gleich sind. Gegebenenfalls müssen sie mit Hilfe der entsprechenden Regler (Fig. 5.5 (1) + (21)) auf den gleichen Wert eingestellt werden.

$$P_1 = P_2 \text{ (dB)}$$

Danach werden die Ausgänge gleichphasig in Serie geschaltet und der Summenpegel gemessen.

Durch Umpolen eines Kanalausganges werden die Ausgänge gegenphasig in Serie geschaltet und der Differenzpegel gemessen.

Bildet man mit den gemessenen Pegelwerten die Gleichung

$$P_{sd} = P_s - P_d \text{ (dB)}$$

so kann man aus der Fig. 5.11 den Phasenwinkel zwischen den beiden Kanälen ermitteln.

The phase angle is determined by the following measurements:

- A Measuring method using oscilloscope with X and Y inputs Lissajous figures
- B Measuring method with two-channel oscilloscope
- C Phasemeter (e.g. Studer No 10.010.201-01)
- D Measuring method with summation and difference levels

Measuring method with summation and difference levels

Measuring is performed when playing back the section of the reference tape associated with the azimuth adjustment by referring to the output levels of channels 1 and 2.

First a check is made to determine whether the levels of the two channels are identical. If not, they are to be adjusted with the corresponding control (Fig. 5.5 (1) + (21)) to matching levels, $P_1 = P_2$ (dB).

Subsequently, the outputs in phase are serially connected and the summation level is measured.

By changing the poles of the channel output, the outputs are serially connected with reversed phasing and the difference level is measured.

When forming the following equation with the measuring level values:

$$P_{sd} = P_s - P_d \text{ (dB)}$$

the phase angle between the two channels can be determined from Fig. 5.11.

Die Spaltjustierschraube (C) des Wiedergabekopfes ist nun so einzustellen, dass P_s maximal, resp. P_d minimal wird.

The azimuth adjustment screw (C) of the reproducing head can now be set in such a fashion that P_s reaches a maximum value while P_d is minimal.

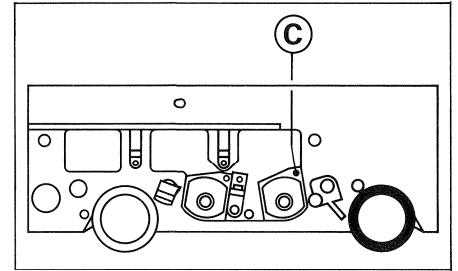

Fig. 5.7

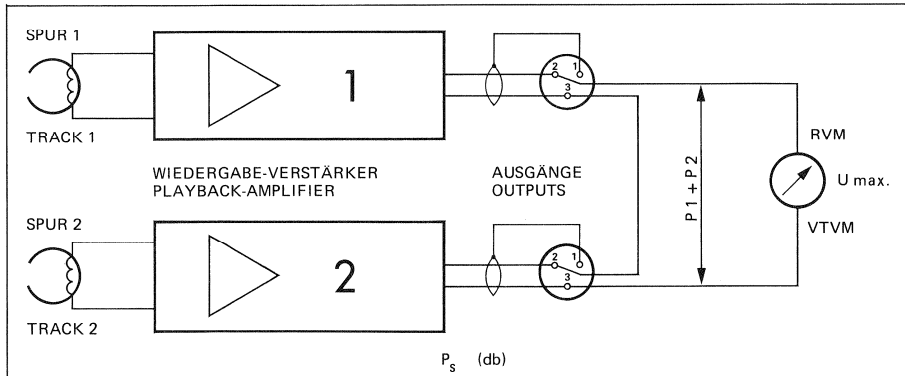

Fig. 5.9

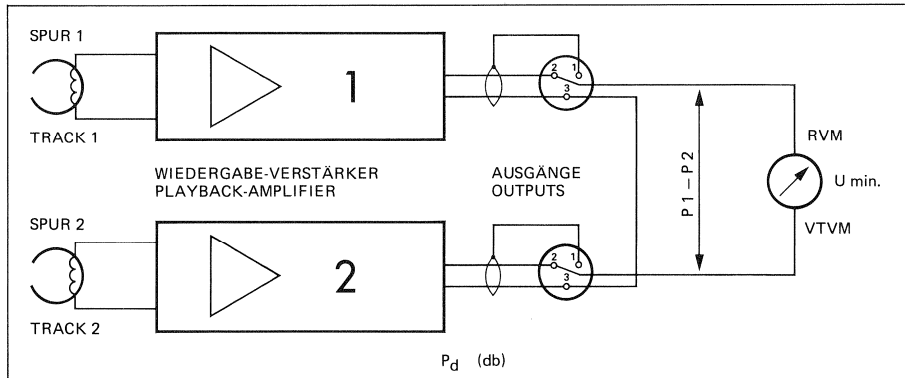

Fig. 5.10

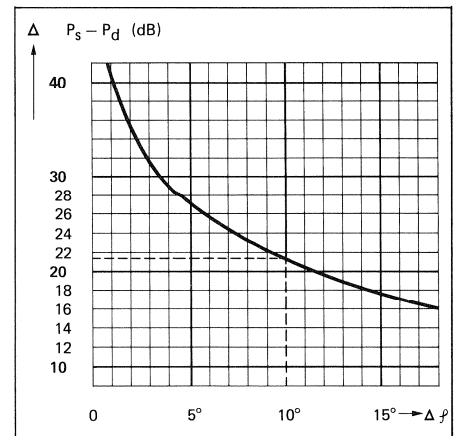

Fig. 5.11

Um bestmögliche Messresultate zu erhalten, soll die Messfrequenz möglichst hoch gehalten werden (ca. 10 kHz).

Dabei besteht jedoch die Gefahr, dass die Kopfspalte der beiden Kanäle auf nebeneinander liegende Maxima der Bandmagnetisierung abgeglichen werden. Um diesen Einstellfehler zu vermeiden, soll vor dem Einstellen, bei phasenrichtiger Reihenschaltung der beiden Ausgänge (Messung von P_s) der Generator von 1 bis 10 kHz durchgestimmt werden.

Tritt dabei Null-Anzeige des Summenpegels auf, so ist der Kopf in der genannten Weise falsch eingestellt.

- Zwischenberuhigungsrolle wieder montieren
- Zwischenberuhigungsrolle taumeln:

Festhalteschraube (A) lösen und die Rolle derart taumeln, dass derselbe Phasenwert wie unter den Punkten A, B, C oder D eingestellt, erreicht wird (Fig. 5.6).

Festhalteschraube wieder festdrehen, darauf achten, dass sich der Phasenwert nicht verändert

- Kopfträgerabdeckung wieder montieren. Auch hierbei darf sich der eingestellte Wert nicht verändern
- Das Magnetband darf am rechten Bandführungsbolzen nicht streifen.

Optimum results are obtained when the measuring frequency is kept as high as possible (approx. 10 kHz).

However, there is danger that the azimuth of the two channels will be adjusted to adjacent maximum tape flux. This adjustment error can be avoided by tuning the generator from 1 to 10 kHz before serially connecting the two correctly phased outputs.

If the summation level is indicated as zero, the head is incorrectly adjusted.

- Re-install intermediate stabilizer roller
- Wobble intermediate stabilizer roller: loosen set screw (A) and wobble intermediate roller until the value set in steps A, B, C, or D is reached (fig. 5.6). Retighten set screw and check that phase value has not changed
- Re-install headblock cover. Again, the set value must not change
- The tape should not touch the right-hand tape guide bolt.

5.3.5**Wiedergabefrequenzgang-Abgleich (FAST)**

1. Gerät auf schnelle Bandgeschwindigkeit (FAST) schalten
2. Entsprechendes Messband einlegen
3. Tonfrequenzmillivoltmeter am Leitungsausgang Kanal 1 (16) CH I anschliessen
4. Messband im Abschnitt "Bezugspegel" auf Wiedergabe starten, Leitungspegel kontrollieren und ggf nachjustieren.
5. Messband im Abschnitt "Frequenzgang" auf Wiedergabe starten.
6. Höhenkorrektur mit Regler TREBLE/FAST (2), Einschub REPROD AMP (CH I) vornehmen.
7. Tiefenkorrektur mit Regler BASS/FAST (3), Einschub REPROD AMP (CH I) im unteren Tonfrequenzbereich (< 100 Hz) provisorisch vornehmen.
8. Bei Zweikanalgeräten:
Frequenzgang-Abgleich für Kanal 2 (CH II) vornehmen, analog Positionen 1 bis 7.
Die zugehörigen Anschlüsse und Regler sind:
Leitungsausgang (36)
Regler TREBLE/FAST (22)
Regler BASS/FAST (23)

Achtung:

Nach diesen Einstellungen ist der Wiedergabebezugspegel nochmals zu überprüfen (5.3.1).

5.3.6**Wiedergabefrequenzgang-Abgleich (SLOW)**

1. Gerät auf langsamer Bandgeschwindigkeit (SLOW) starten
2. Entsprechendes Messband auflegen
3. Tonfrequenzmillivoltmeter an Leitungsausgang Kanal 1 (16) CH I anschliessen
4. Messband im Abschnitt "Bezugspegel" auf Wiedergabe starten, Leitungspegel kontrollieren und ggf nachjustieren
5. Messband im Abschnitt "Frequenzgang" auf Wiedergabe starten.
6. Höhenkorrektur mit Regler TREBLE/SLOW (6), Einschub REPROD AMP (CH I) vornehmen.

5.3.5**Balancing reproduction frequency response (FAST)**

1. Set machine to fast tape speed (FAST).
2. Mount appropriate test tape.
3. Connect audio-frequency millivoltmeter to line output of channel 1 (16) CH I
4. Play reference tape at section "Reference level", check line level and adjust if necessary
5. Play "Frequency range" section of reference tape.
6. Adjust treble with TREBLE/FAST (2) control, plug-in module REPROD AMP (CH I)
7. Temporarily correct bass with BASS/FAST control (3), plug-in module REPROD AMP (CH I) in the lower audio frequency range (< 100 Hz).
8. For two-channel units:
Balance frequency range for channel 2 (CH II) analogous to positions 1 – 7.
The corresponding connections and controls are as follows:
Line output (36)
TREBLE/FAST control (26)
BASS/FAST control (27)

Caution:

Recheck the adjustments of the reproduction levels after making the above adjustments (5.3.1).

5.3.6**Balancing reproduction frequency response (SLOW)**

1. Set machine to slow tape speed (SLOW)
2. Mount appropriate test tape
3. Connect audio-frequency millivoltmeter to line output of channel 1 (16) CH I.
4. Play reference tape at section "Reference level", check line level and adjust if necessary.
5. Play "Frequency range" section of reference tape.
6. Adjust treble with TREBLE/SLOW (6) control, plug-in module REPROD AMP (CH I).

- | | |
|--|--|
| <p>7. Tiefenkorrektur mit Regler BASS/SLOW (7), Einschub REPROD AMP (CH I) im unteren Tonfrequenzbereich (< 100 Hz) provisorisch vornehmen.</p> <p>8. Bei Zweikanalgeräten:
Frequenzgang-Abgleich für Kanal 2 (CH II) vornehmen, analog Positionen 1 bis 7.
Die zugehörigen Anschlüsse und Regler sind:
Leitungs-Ausgang (36)
Regler TREBLE/SLOW (26)
Regler BASS/SLOW (27)</p> | <p>7. Temporarily correct bass with BASS/SLOW control (7), plug-in module REPROD AMP (CH I) in the lower audio frequency range (< 100 Hz).</p> <p>8. For two-channel units:
Balance frequency range for channel 2 (CH II) analogous to positions 1 – 7.
The corresponding connections and controls are as follows:
Line output (36)
TREBLE/SLOW control (26)
BASS/SLOW control (27)</p> |
|--|--|

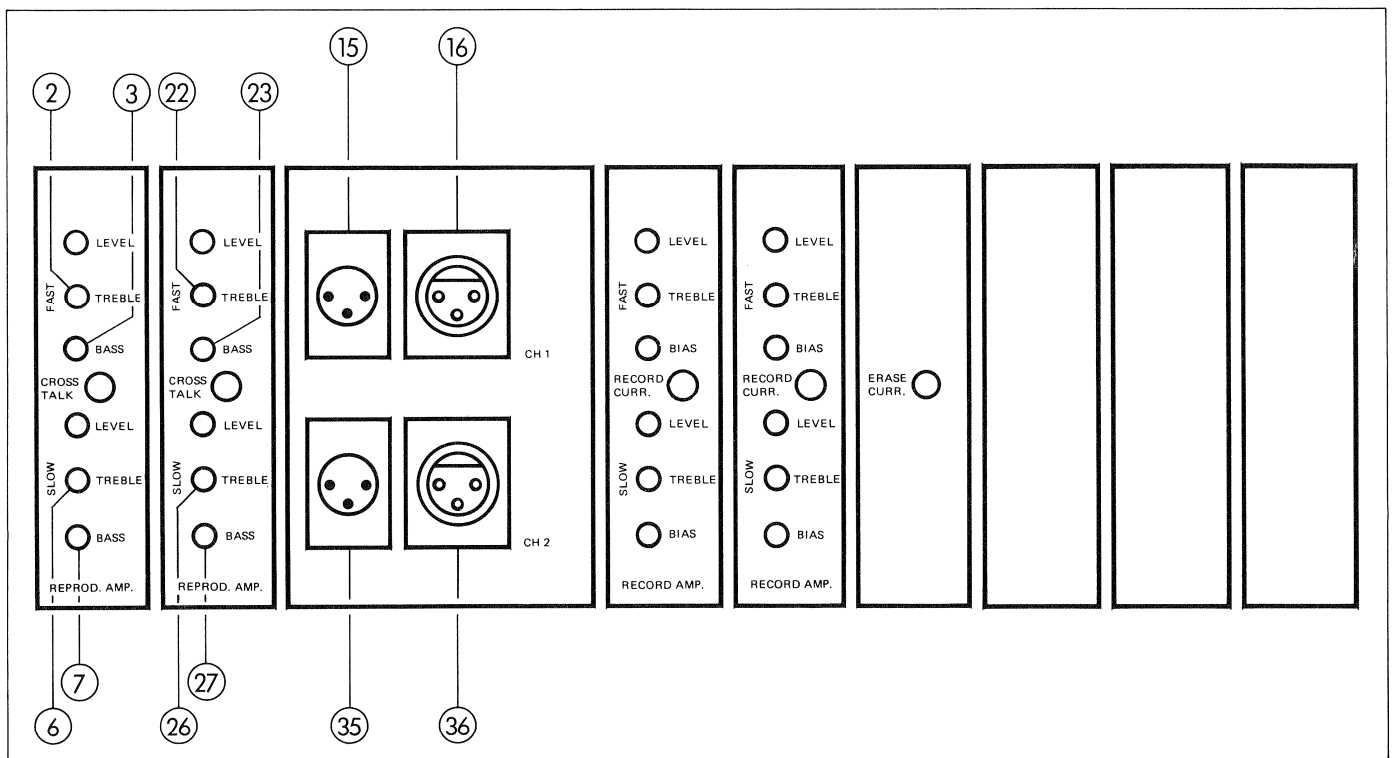

Fig. 5.12

Achtung:
Nach diesen Einstellungen ist der Wiedergabe-
bezugspegel nochmals zu überprüfen (5.3.2).

Caution:
Recheck the adjustments of the reproduce levels
after making the above adjustments (5.3.2).

5.4 AUFNAHMEEINSTELLUNGEN

Anmerkung:

Überall, wo die Anwendung von neuem Band vorgeschrieben ist, kann auch bespieltes Band verwendet werden. Die Aufzeichnung wird beim Aufnahmevorgang gelöscht.

5.4.1 Kontrolle der Oszillatorfrequenz

Anmerkung:

Um nach der Vormagnetisierungseinstellung eine möglichst geringe Abweichung der Oszillatorfrequenz zu erhalten, sollte der Arbeitspunkt bei einem Eingangsspegel von 10 kHz –20 dB für beide Geschwindigkeiten ungefähr eingestellt werden.

1. Gerät auf langsame Bandgeschwindigkeit schalten.
2. Digital-Frequenzzähler an Anschluss (40) Löschstrom (ERASE CURR) anstecken.
3. Neuwertiges, leeres Band der gewünschten Bandsorte auflegen und das Gerät auf Aufnahme starten.
4. Oszillatorfrequenz messen. Diese soll 150 kHz \pm 3 kHz betragen. Liegt die Oszillatorfrequenz ausserhalb des Toleranzbereiches, muss der Oszillator nachjustiert werden.
5. Gerät ausschalten. Oszillator-Einschub herausziehen. Verlängerungssteckkarte (1.080.940) einsetzen und Oszillator-Einschub auf Verlängerungssteckkarte aufstecken.
6. Gerät auf langsame Bandgeschwindigkeit schalten und auf Aufnahme starten.
7. Oszillatorkarte (37) auf 150 kHz abgleichen.
8. Gerät ausschalten. Verlängerungssteckkarte herausziehen. Oszillator-Einschub in Verstärkerkorb einsetzen.
9. Gerät auf langsame Bandgeschwindigkeit schalten und auf Aufnahme starten.
10. Kontrollmessung der Oszillator-Frequenz. Liegt die Frequenz des eingesteckten Oszillator-Einschubes ausserhalb des Toleranzbereiches, sind die Einstellungen gemäss Positionen 5 bis 7 zu wiederholen.

5.4 ADJUSTMENT FOR RECORD MODE

Note:

Wherever reference is made to new tape, recorded tape may also be used. However, the recording will be erased.

5.4.1 Checking of oscillator frequency

Note:

To minimize the deviation of the oscillator frequency after adjusting the tape bias setting, the operational setting should be adjusted to an input level of 10 kHz –20 dB with both speeds.

1. Switch machine to slow tape speed.
2. Connect digital frequency counter to the terminal (40) for erase current (ERASE CURR).
3. Mount new, unrecorded tape of the appropriate type and start the unit in record mode.
4. Measure oscillator frequency. It should read 150 kHz \pm 3 kHz. If the oscillator frequency falls outside the tolerance range, the oscillator frequency must be recalibrated.
5. Switch off tape unit. Pull out oscillator module. Insert extension board (1.080.940) and clip oscillator module to extension board.
6. Start tape unit at slow tape speed in record mode.
7. Balance oscillator coil (37) to 150 kHz.
8. Switch off tape unit. Pull out extension board and re-install oscillator module in amplifier rack.
9. Start tape unit at slow speed in record mode.
10. Verifying oscillator frequency. If the frequency of the plugged-in oscillator board falls outside the tolerance range, the adjustments according to steps 5 to 7 must be repeated.

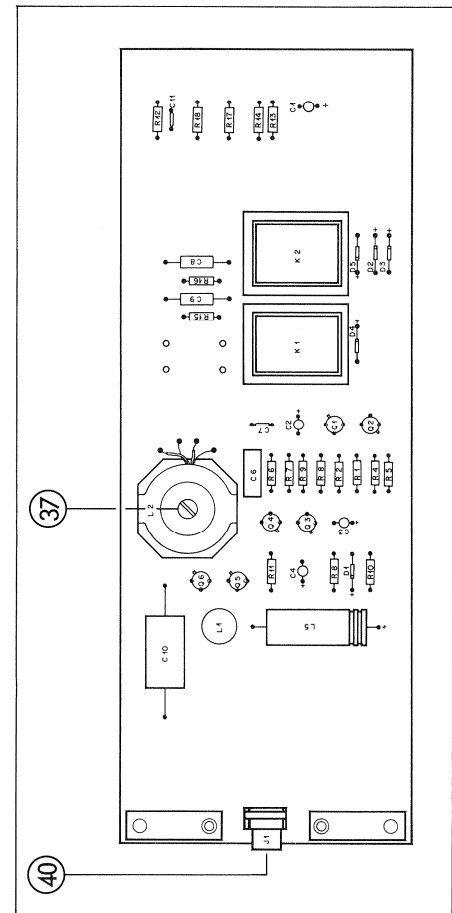

Fig. 5.13

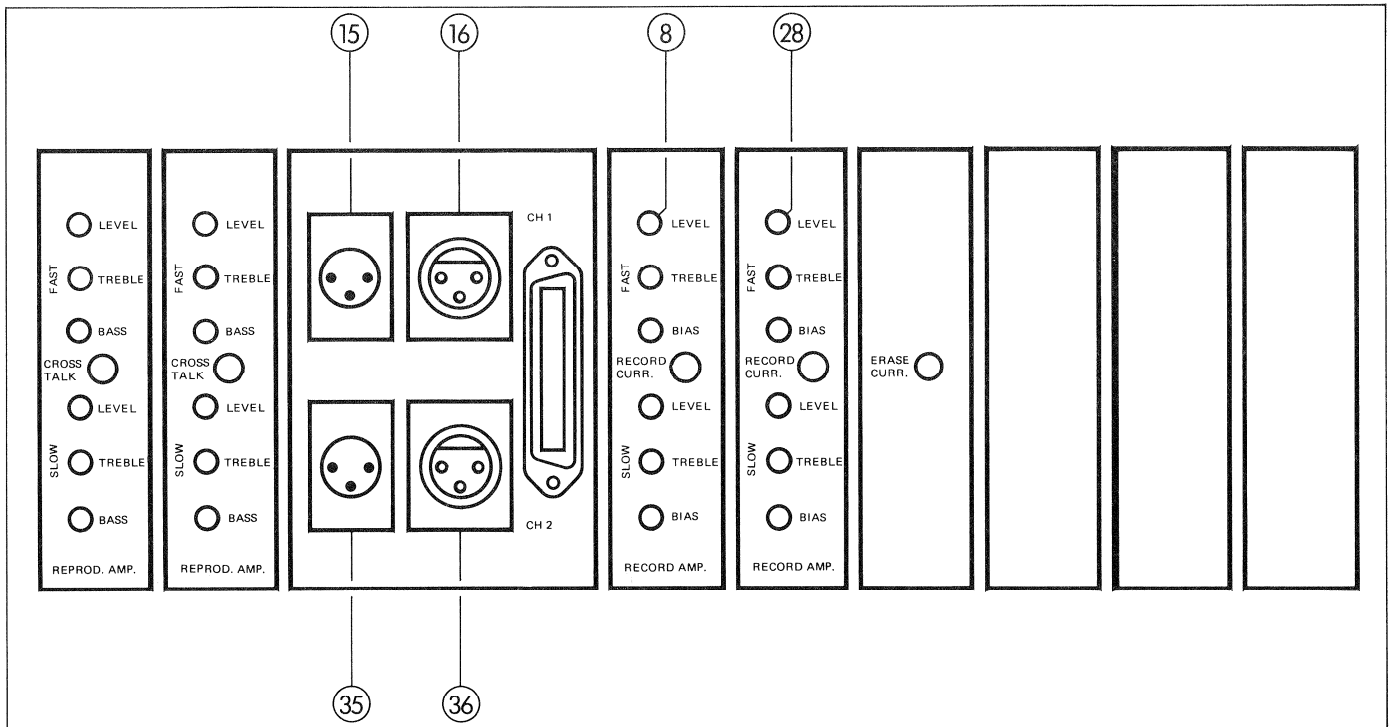

Fig. 5.14

5.4.2

Pegleinstellen der Aufnahmeverstärker (FAST)

1. Gerät auf schnelle Bandgeschwindigkeit schalten.
2. Tonfrequenz-Millivoltmeter an Leitungsausgang Kanal 1 (16), (CH I) anschliessen.
3. Tonfrequenzgenerator an Leitungseingang Kanal 1 (15), (CH I) anschliessen.
Frequenz: entsprechender Bezugspegel
Pegel: Leitungspegel
4. Neuwertiges, leeres Band der gewünschten Bandsorte auflegen und auf Aufnahme starten.
5. Regler LEVEL/FAST (8), Einschub RECORD AMP (CH I), auf Leitungspegel einstellen.
6. Bei Zweikanalgeräten:
Pegleinstellung für Kanal 2 (CH II) vornehmen, analog Positionen 1 bis 5.
Die zugehörigen Anschlüsse und Regler sind:
Leitungsausgang (36)
Leitungseingang (35)
Regler LEVEL/FAST (28)

5.4.2

Level adjustment of record amplifier (FAST)

1. Start tape unit with tape speed selector set to FAST.
2. Connect audio-frequency millivoltmeter to line output channel 1 (16) (CH I).
3. Connect AF generator to line input channel 1 (15), (CH I).
Frequency: corresponding reference level
Level: line level
4. Install new, unrecorded tape of desired quality and start in record mode.
5. Adjust LEVEL/FAST control (8), circuit board RECORD AMP (CH I) to line level.
6. For two-channel units:
Adjust level for channel 2 (CH II) analogous to steps 1 -- 5
The associated connections and controls are as follows:
Line output (36)
Line input (35)
LEVEL/FAST control (28)

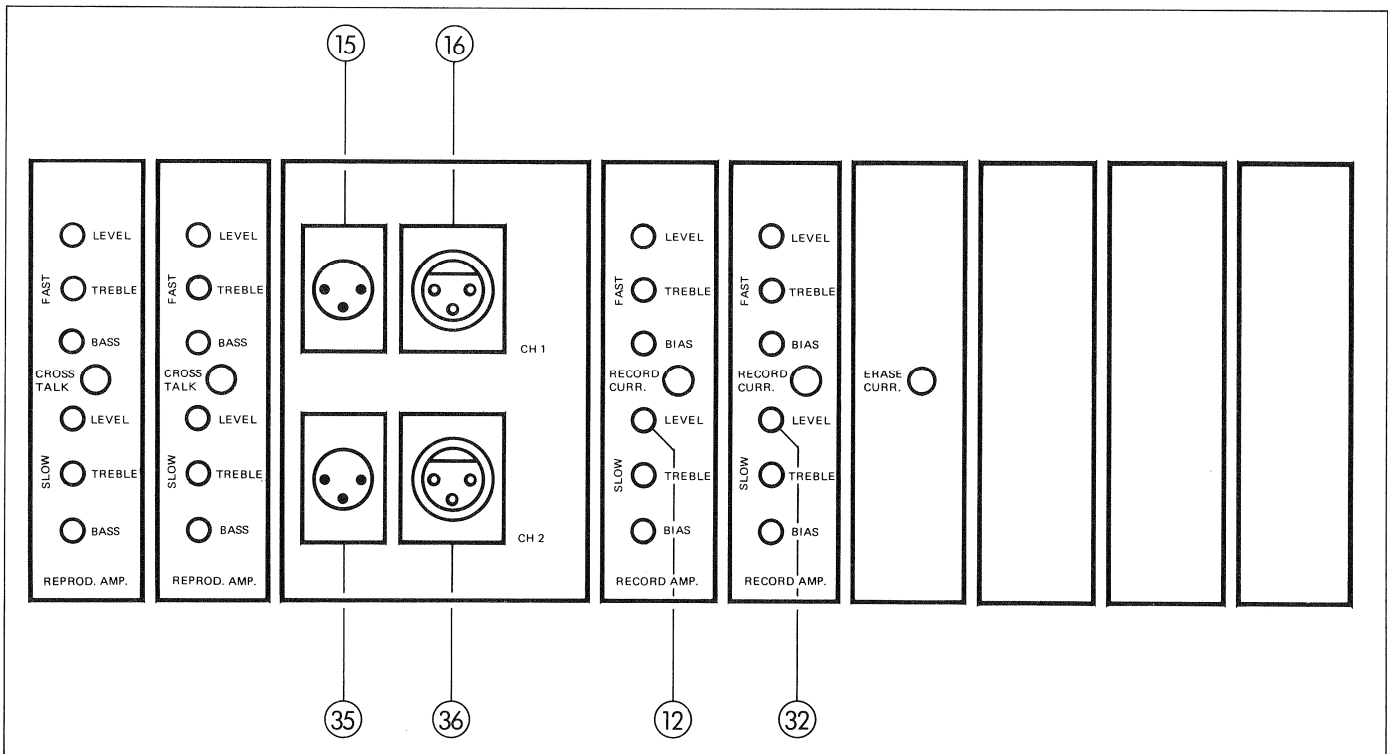

Fig. 5.15

5.4.3 Pegeleinstellen der Aufnahmeverstärker (SLOW)

- Gerät auf langsame Bandgeschwindigkeit schalten.
- Tonfrequenz-Millivoltmeter an Leitungs-Ausgang Kanal 1 (16) (CH I) anschliessen.
- Tonfrequenz-Generator an Leitungs-Eingang Kanal 1 (15) (CH I) anschliessen.
Frequenz: entsprechender Bezugspegel
Pegel: Leitungspegel
- Neuwertiges, leeres Band der gewünschten Bandsorte auflegen und auf Aufnahme starten.
- Regler LEVEL/SLOW (12), Einschub RECORD AMP (CH I), auf Leitungspegel einstellen.
- Bei Zweikanalgeräten:
Pegeleinstellung für Kanal 2 (CH II) vornehmen, analog Positionen 1 bis 5.
Die zugehörigen Anschlüsse und Regler sind:
Leitungs-Ausgang (36)
Leitungs-Eingang (35)
Regler LEVEL/SLOW (32)

5.4.3 Level adjustment of record amplifier (SLOW)

- Start tape unit with tape speed selector set to SLOW.
- Connect audio-frequency millivoltmeter to line output channel 1 (16) (CH I).
- Connect audio-frequency generator to line input channel 1 (15), (CH I).
Frequency: corresponding reference level
Level: line level
- Install new, unrecorded tape of desired quality and start in record mode.
- Adjust LEVEL/SLOW control (12), circuit board RECORD AMP (CH I) to line level.
- For two-channel units:
Adjust level for channel 2 (CH II) analogous to steps 1 – 5.
The associated connections and controls are as follows:
Line output (36)
Line input (35)
LEVEL/SLOW control (32)

5.4.4**Aufnahmekopf Spalteinstellung (AZIMUT)**

Nur für MONO-Geräte

1. Gerät auf langsame Bandgeschwindigkeit schalten.
2. Tonfrequenz-Generator an den Leitungseingang (15) anschliessen.
Pegel: 20 dB unter Bezugspegel (CCIR)
10 dB unter Operating Level (NAB)
Frequenz: 10 kHz
3. Tonfrequenz-Millivoltmeter an Leitungsausgang (16) (CH I) anschliessen.
4. Neuwertiges, leeres Band der gewünschten Bandsorte auflegen und das Gerät auf Aufnahme starten.
5. Mit der Spaltjustierschraube (17) (siehe Fig. 5.16) den Aufnahmekopf auf Pegelmaximum am Ausgang justieren.
6. Falls eine starke Azimut-Korrektur erforderlich war, sind die Einstellungen gemäss Abschnitt 5.4.2 und 5.4.3 (Pegeleinstellung der Aufnahmeverstärker) zu wiederholen.

Für Stereo- oder 2-Spur Geräte

Bei Tonbandgeräten beeinflusst die Stellung des Kopfspaltes (Winkel zur Bandaufrichtung) nicht nur den Pegel der hohen Frequenzen, sondern auch die Phasenlage zwischen den Kanälen. Diese stellt ein wesentlich besseres Kriterium zur Spaltjustierung dar, als die Einstellung nach Pegelmaximum. Um die Phaseinstellung richtig durchzuführen, ist darauf zu achten, dass die Zwischenberuhigungsrolle richtig eingestellt ist (siehe Abschnitt 5.3.4).

Die Phaseinstellung kann nach verschiedenen Methoden ausgeführt werden:

A Messmethode mit Oszilloskop mit X und Y Eingang (Lissajoux-Figuren)

B Messmethode mit 2-Kanal Oszilloskop

1. Gerät auf schnelle Bandgeschwindigkeit schalten
2. Tonfrequenzgenerator parallel an die beiden Leitungseingänge Kanal 1 (15) und Kanal 2 (35) (CH I + CH II) anschliessen.
Pegel: 20 dB unter Bezugspegel (CCIR)
10 dB unter Operating Level (NAB)
Frequenz: 10 kHz
3. 2-Kanal Oszilloskop an Leitungsausgang Kanal 1 (16) und Kanal 2 (36) anschliessen.

5.4.4**Record head azimuth adjustment**

For Mono units only:

1. Switch machine to slow tape speed.
2. Connect audio-frequency generator to line input (15).
Level: 20 dB below reference level (CCIR)
10 dB below operating level (NAB)
Frequency: 10 kHz
3. Connect audio-frequency millivoltmeter to line output (16) (CH I).
4. Install new, unrecorded tape of desired type and start the machine in record mode.
5. Adjust output of record head to maximum level with azimuth adjustment screw (17) see fig. 5.16
6. If the azimuth adjustment was significant it is necessary to repeat the adjustments listed in 5.4.2 and 5.4.3 (level adjustments of the recording amplifiers).

For Stereo or two-track units:

The adjustment of the azimuth angle relative to the tape direction not only affects the level of high frequencies but also the phasing between two channels. This criterion in azimuth adjustment is more important than adjustment for maximum level. For correct adjustment of the phasing, the intermediate stabilizer roller must also be adjusted correctly (see 5.3.4).

The phase setting can be performed according to various methods:

A Measuring method using oscilloscope with X and Y input (Lissajoux figures)

B Measuring method using two-channel oscilloscope

1. Switch unit to fast tape speed.
2. Connect audio-frequency generator in parallel to the two line inputs of channel 1 (15) and channel 2 (35) (CH I + CH II).
Level: 20 dB below reference level (CCIR)
Frequency: 10 kHz
3. Connect two-channel oscilloscope to line output of channel 1 (16) and channel 2 (36).

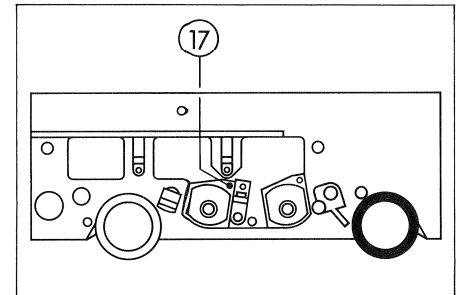

Fig. 5.16

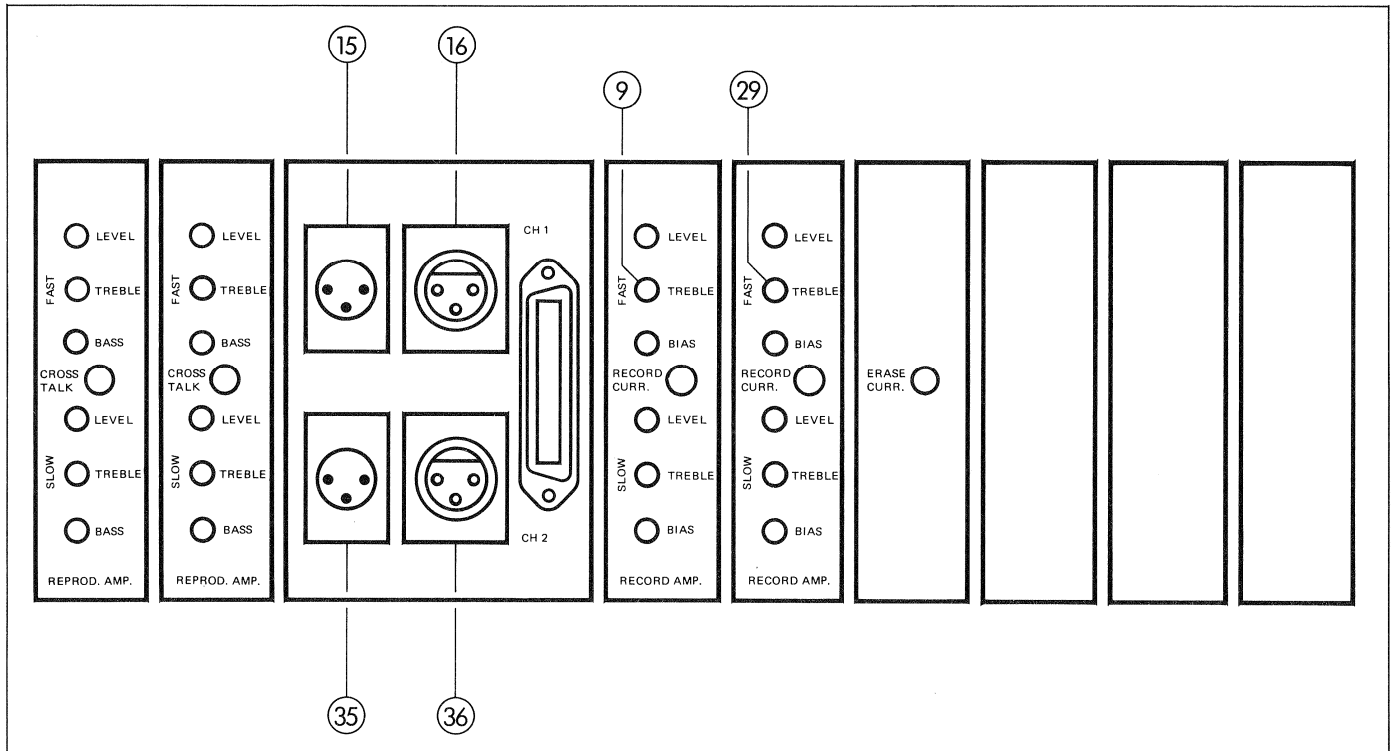

Fig. 5.17

4. Neuwertiges, leeres Band der gewünschten Sorte auflegen und Gerät auf Aufnahme starten.
5. Die beiden Ausgangspegel des Gerätes auf identische Amplitude vorabgleichen (Regler TREBEL/FAST (9) / (29) an den Einschüben RECORD AMP) $\leq 0,5$ dB.
6. Aufnahmekopf mit Spaltjustierschraube (17) Fig. 5.16 auf Pegelmaximum am Ausgang einstellen.
7. Falls eine starke Azimut-Korrektur erforderlich war, sind die Einstellungen nach Punkt 5 neu durchzuführen.
8. Aufnahmekopf mit Spaltjustierschraube (17) Fig. 5.16 auf geringste Phasenwinkel-differenz einstellen.
9. Gerät auf langsame Bandgeschwindigkeit umschalten.
10. Aufnahmekopf mit Spaltjustierschraube (17) Fig. 5.16 bei langsamer Bandgeschwindigkeit auf optimale Phasenwinkel-differenz einstellen.
(Anzeigeverzögerung beachten, deshalb ist die Azimuteinstellung besonders langsam auszuführen.)
11. Gerät auf höhere Bandgeschwindigkeit umschalten und die Phasendifferenz kontrollieren. Die Phasendifferenz zwischen lang-
4. Mount new, unrecorded tape of the desired quality and start machine in record mode
5. Pre-adjust the two output levels for identical amplitude (TREBLE/FAST control (9) / (29) on boards RECORD AMP) = 0.5 dB.
6. Adjust azimuth of recording head with azimuth adjustment screw (17) Fig. 5.16 until maximum level appears at the output
7. If the azimuth correction was significant, the adjustments stated in step 5 must be repeated.
8. Adjust record head by turning azimuth adjustment screw (17) Fig. 5.16 to obtain minimum phase-angle difference
9. Switch machine to slow tape speed.
10. Adjust record head by turning azimuth adjustment screw (17) Fig. 5.16 at slow tape speed to obtain optimum phase-angle difference.
(Observe delay in readings; this will require that the azimuth adjustment be made slowly).
11. Switch machine to fast tape speed and check phase difference. The phase difference between slow and fast tape speed

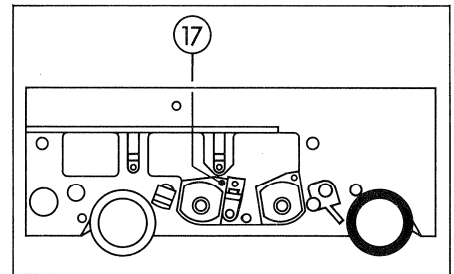

Fig. 5.16

samer und schneller Bandgeschwindigkeit ergibt unterschiedliche Werte, welche auf gleichmässige Plus- und Minusabweichungen zwischen SLOW und FAST einzustellen sind.

12. Die Eingangsfrequenz kontinuierlich von 10 kHz auf 1 kHz absenken. Die Phase darf nicht drehen, sonst wurde auf falsches Pegelmaximum abgeglichen.

C Messmethode mit Phasenmeter (z.B. STUDER Nr. 10.010.201-01)

D Phasenmethode

D Phasenmethode

1. Gerät auf langsame Bandgeschwindigkeit schalten.
2. Tonfrequenz-Generator an die beiden Leitungseingänge Kanal 1 (15) und Kanal 2 (35) (CH I + CH II) anschliessen.
Pegel: 20 dB unter Bezugspegel (CCIR)
10 dB unter Operating Level (NAB)
Frequenz: 10 kHz
3. Neuwertiges, leeres Band der gewünschten Bandsorte auflegen und das Gerät auf Aufnahme starten.
4. Die weiteren Mess- und Einstellvorgänge sind analog wie unter Abschnitt 5.3.4), Absatz D beschrieben auszuführen.
Die zugehörigen Anschlüsse und Regler sind:
Leitungsausgänge 1 und 2 (16) + (36)
Regler TREBLE/FAST (9) / (29)
Spaltjustierschraube (17)

5.4.5

Vormagnetisierung

Bei der Wahl der Vormagnetisierungs-Einstellung ist ein Kompromiss zu schliessen zwischen Verzerrungsgrad, Frequenzgang, Modulationsrauschen und Aussteuerungsgrad. Die Vormagnetisierungs-Einstellung wird weiter nicht allein durch die Bandsorte bestimmt, sondern ist stark abhängig von der Spaltbreite des Aufnahmekopfes.

Eine Korrektur der Vormagnetisierung ändert den Frequenzgang wie auch den Klirrfaktor.

Bei der Vormagnetisierungs-Einstellung wird der HF-Strom (bei konstantem NF-Signal) soweit über das Empfindlichkeitsmaximum des entsprechenden Bandes erhöht, bis die NF-Ausgangsspannung um einen bestimmten Betrag ΔE abgesunken ist.

will show different readings. These are to be balanced for identical positive and negative aberrations between SLOW and FAST.

12. Continuously lower input frequency from 10 kHz to 1 kHz. If the phase shifts, the maximum level was set incorrectly.

C Measuring method with phase meter (e.g. STUDER No. 10.010.201-01).

D Phasing method

D Phasing method

1. Switch machine to slow tape speed
2. Connect audio-frequency generator to both line inputs channel 1 (15) and channel 2 (35) (CH I + CH II)
Level: 20 dB below reference level (CCIR)
10 dB below operating level (NAB)
Frequency: 10 kHz
3. Install new, unrecorded tape of the desired quality and start the machine in record mode
4. The subsequent measuring and adjustment settings to be performed are analogous to those described in chap. 5.3.4, item D. The associated connections and controls are as follows:
Line outputs 1 and 2 (16) + (36)
TREBLE/FAST control (9)/(29)
Azimuth adjustment screw (17)

5.4.5

Tape bias

When selecting the tape bias adjustment, a compromise has to be made between distortion level, frequency response, modulation noise, and modulation level. The tape bias setting is determined not only by the tape quality but is strongly dependent on the gap width of the record head.

A correction of the bias setting therefore affects the frequency response as well as the distortion level.

When readjusting the bias setting, the HF current (with constant AF signal) is increased beyond the maximum sensitivity of the corresponding tape until the AF output voltage drops by a specific value ΔE .

Der Vormagnetisierungs-Abgleich erfolgt mit einer Modulationsfrequenz von 10 kHz. Um Übersteuerungen und Fehlmessungen zu vermeiden, ist der Eingangspegel auf -20 dB gegenüber Bezugspegel (operating level) zu reduzieren.

Balancing of the bias setting is performed with a modulation frequency of 10 kHz. To avoid over-modulation and erroneous readings, the input level is to be reduced to -20 dB as compared to the reference level (operating level).

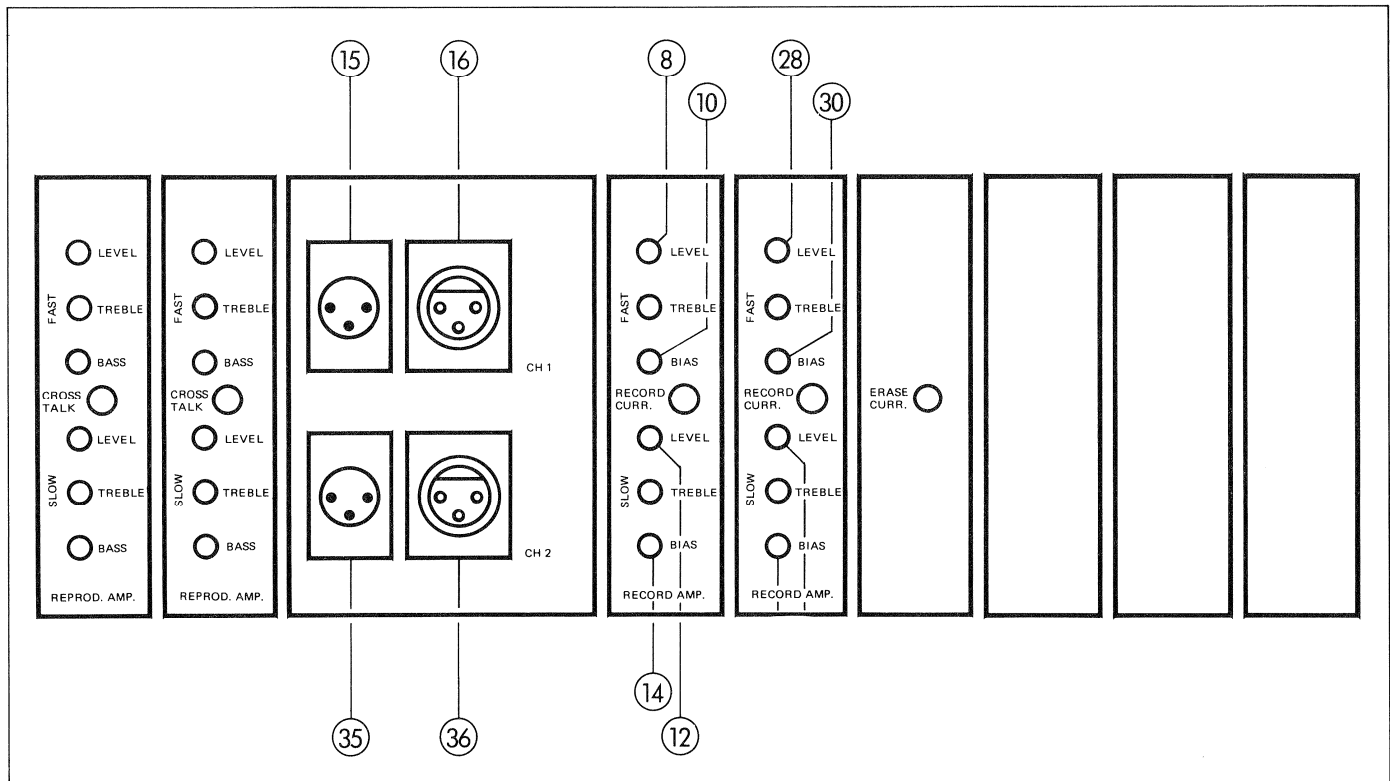

Fig. 5.18

5.4.6 Vormagnetisierung FAST

1. Gerät auf schnelle Bandgeschwindigkeit schalten.
2. Tonfrequenz-Millivoltmeter an Leitungsausgang Kanal 1 (16) (CH I) anschliessen.
3. Tonfrequenz-Generator an Leitungseingang Kanal 1 (15) (CH I) anschliessen.
Frequenz: 10 kHz
Pegel: 20 dB unter Bezugspegel
4. Neuwertiges, leeres Band auflegen und Gerät auf Aufnahme starten.
5. Regler LEVEL/FAST (8), Einschub RECORD AMP (CH I), vorläufig so einstellen, dass sich am Tonfrequenz-Millivoltmeter eine Anzeige von 20 dB unter dem Bezugspegel einstellt.

5.4.6 Bias setting FAST

1. Switch machine to fast tape speed.
2. Connect audio-frequency millivoltmeter to line output channel 1 (16) (CH I).
3. Connect audio-frequency generator to line input channel 1 (15) (CH I)
Frequency: 10 kHz
Level: 20 dB below reference level
4. Mount new, unrecorded tape and start machine in record mode.
5. Temporarily adjust LEVEL/FAST control (8), board RECORD AMP (CH I) to a setting where the audio-frequency millivoltmeter displays a value of 20 dB below the reference level.

- | | |
|---|--|
| <p>6. Regler BIAS/FAST (10), Einschub RECORD AMP (CH I), vom linken Anschlag in Uhrzeigerrichtung aufdrehen, bis die Maximal-Anzeige am Tonfrequenz-Millivoltmeter erreicht ist (Empfindlichkeits-Maximum des Tonbandes). Den Regler in Uhrzeigerrichtung weiterdrehen, bis die Anzeige am Tonfrequenz-Millivoltmeter um den in Fig. 5.20 aufgeführten Wert gesunken ist.</p> | <p>6. Open BIAS/FAST control (10), board RECORD AMP (CH I) from the left limit position in a clockwise direction until the maximum reading on the audio-frequency millivoltmeter is obtained (sensitivity limit of the tape). Continue rotation in clockwise direction until the audio-frequency millivoltmeter shows a reading which has dropped by the value indicated in Fig. 5.20.</p> |
| <p>7. Tonfrequenzgenerator auf 1 kHz bei Bezugspegel einstellen, PegelEinstellung kontrollieren und ggf nachjustieren.</p> | <p>7. Adjust audio-frequency generator to 1 kHz at reference level. Check level and if necessary, adjust.</p> |
| <p>8. Bei Zweikanalgeräten:
Vormagnetisierungs-Abgleich für Kanal 2 (CH II) vornehmen, analog Positionen 1 bis 7.
Die zugehörigen Anschlüsse und Regler sind:
Leitungs-Ausgang (36)
Leitungs-Eingang (35)
Regler LEVEL/FAST (28)
Regler BIAS/FAST (30)</p> | <p>8. For two-channel units:
Calibrate bias setting for channel 2 (CH II) analogous to steps 1 to 7.
The associated connections and controls are as follows:
Line output (36)
Line input (35)
LEVEL/FAST control (28)
BIAS/FAST control (30)</p> |

5.4.7

Vormagnetisierung SLOW

1. Gerät auf langsame Bandgeschwindigkeit schalten.
2. Tonfrequenz-Millivoltmeter an Leitungsausgang Kanal 1 (16) (CH I) anschliessen.
3. Tonfrequenz-Generator an Leitungseingang Kanal 1 (15) (CH I) anschliessen.
Frequenz: 10 kHz
Pegel: 20 dB unter Bezugspegel
4. Neuwertiges, leeres Band der gewünschten Bandsorte auflegen und Gerät auf Aufnahme starten.
5. Regler LEVEL/SLOW (12), Einschub RECORD AMP (CH I), vorläufig so einstellen, dass sich am Tonfrequenz-Millivoltmeter eine Anzeige von 20 dB unter dem Bezugspegel einstellt.
6. Regler BIAS/SLOW (14), Einschub RECORD AMP (CH I), vom linken Anschlag in Uhrzeigerrichtung aufdrehen, bis die Maximal-Anzeige am Tonfrequenz-Millivoltmeter erreicht ist (Empfindlichkeits-Maximum des Tonbandes). Den Regler in Uhrzeigerrichtung weiterdrehen, bis die Anzeige am Tonfrequenz-Millivoltmeter um den in Fig. 5.20 aufgeführten Wert gesunken ist.
7. Tonfrequenzgenerator auf 1 kHz bei Bezugspegel einstellen, PegelEinstellung kontrollieren und ggf nachjustieren.

5.4.7

Bias setting SLOW

1. Switch machine to fast slow speed
2. Connect audio frequency millivoltmeter to line output channel 1 (16) (CH I).
3. Connect audio-frequency generator to line input channel 1 (15) (CH I)
Frequency: 10 kHz
Level: 20 dB below reference level
4. Mount new, unrecorded tape and start machine in record mode.
5. Temporarily adjust LEVEL/SLOW control (12), board RECORD AMP (CH I) to a setting where the audio-frequency millivoltmeter displays a value of 20 dB below the reference level.
6. Open BIAS/SLOW control (14), board RECORD AMP (CH I) from the right limit position in a clockwise direction until the maximum reading at the audio-frequency millivoltmeter is obtained (sensitivity limit of the tape). Continue rotation in clockwise direction until the audio-frequency millivoltmeter shows a reading which has dropped by the value indicated in Fig. 5.20.
7. Adjust audio-frequency generator to 1 kHz at reference level. Check level and if necessary, adjust.

8. Bei Zweikanalgeräten:
Vormagnetisierungs-Abgleich für Kanal 2 (CH II) vornehmen, analog Positionen 1 bis 7.
Die zugehörigen Anschlüsse und Regler sind:
Leitungs-Ausgang (36)
Leitungs-Eingang (35)
Regler LEVEL/SLOW (32)
Regler BIAS/SLOW (34)
8. For two-channel units:
Calibrate bias setting for channel 2 (CH II) analogous to steps 1 to 7.
The associated connections and controls are as follows:
Line output (36)
Line input (35)
LEVEL/SLOW control (32)
BIAS/SLOW control (34).

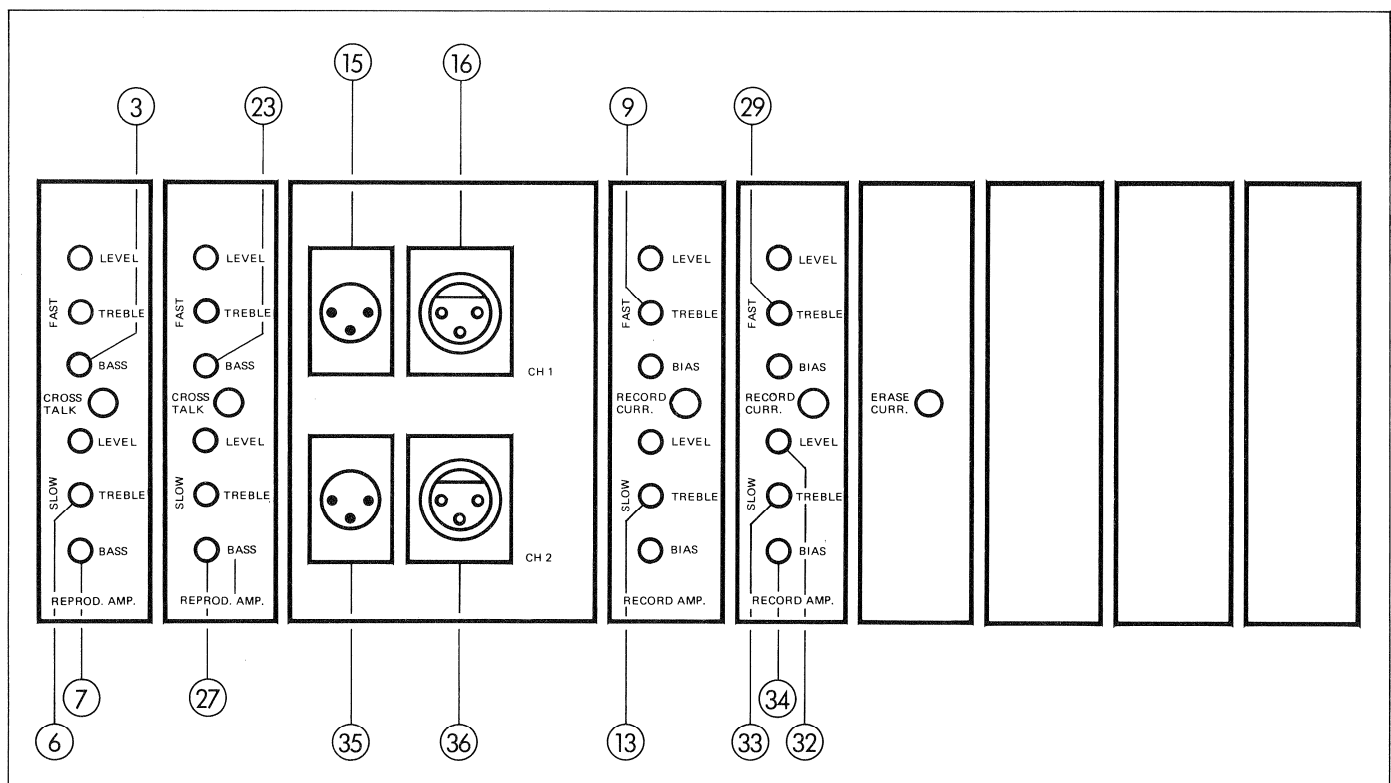

Fig. 5.19

5.4.8 Aufnahmefrequenzgang Abgleich (FAST)

1. Gerät auf schnelle Bandgeschwindigkeit schalten.
2. Tonfrequenz-Millivoltmeter an Leitungs-Ausgang Kanal 1 (16) (CH I) anschliessen.
3. Tonfrequenz-Generator an Leitungs-Eingang Kanal 1 (15) (CH I) anschliessen.
Pegel: 20 dB unter Bezugspegel
4. Neuwertiges, leeres Band der gewünschten Bandsorte auflegen und auf Aufnahme starten.
5. Höhenkorrektur mit Regler TREBLE/FAST (9), Einschub RECORD AMP (CH I), vornehmen.

5.4.8 Balancing of recording frequency response (FAST)

1. Switch machine to fast tape speed.
2. Connect audio-frequency millivoltmeter to line output channel 1 (16) (CH I)
3. Connect audio-frequency generator to line input channel 1 (15) (CH I).
Level: 20 dB below reference level
4. Mount new, unrecorded tape of desired quality and start machine in record mode.
5. Perform treble correction with TREBLE/FAST control (9), board RECORD AMP (CH I).

- | | |
|---|---|
| <p>6. Tonfrequenz-Generator im unteren Frequenzbereich (30 ... 100 Hz) variieren.</p> | <p>6. Vary audio-frequency generator at lower frequency range (30 ... 100 Hz).</p> |
| <p>7. Tiefenkorrektur mit Regler BASS/FAST (3) , Einschub REPROD AMP (CH I), vornehmen. Auf linearen Ausgangspegel einstellen.</p> | <p>7. Perform bass correction with BASS/FAST control (3), board REPROD AMP (CH I). Adjust for linear output level.</p> |
| <p>8. Bei Zweikanalgeräten:
Frequenzgang-Abgleich für Kanal 2 (CH II) vornehmen, analog Positionen 1 bis 7.
Die zugehörigen Anschlüsse und Regler sind:
Leitungs-Ausgang (36)
Leitungs-Eingang (35)
Regler BASS/FAST (23)
Regler TREBLE/FAST (29)</p> | <p>8. For two-channel machines:
Balance frequencies for channel 2 (CH II) analogous to steps 1 to 7.
The associated connections and controls are as follows:
Line output (36)
Line input (35)
BASS/FAST control (23)
TREBLE/FAST control (29)</p> |

5.4.9**Aufnahmefrequenzgang Abgleich (SLOW)**

1. Gerät auf langsame Bandgeschwindigkeit schalten.
2. Tonfrequenz-Millivoltmeter an Leitungs-Ausgang Kanal 1 (16) (CH I) anschliessen.
3. Tonfrequenz-Generator an Leitungs-Eingang Kanal 1 (15) (CH I) anschliessen.
Pegel: 20 dB unter Bezugspegel
4. Neuwertiges, leeres Band der gewünschten Bandsorte auflegen und auf Aufnahme starten.
5. Höhenkorrektur mit Regler TREBLE/SLOW (13) , Einschub RECORD AMP (CH I), vornehmen.
6. Tonfrequenz-Generator im unteren Frequenzbereich (30 ... 100 Hz) variieren.
7. Tiefenkorrektur mit Regler BASS/SLOW (7) , Einschub RECORD AMP (CH I), vornehmen. Auf linearen Ausgangspegel einstellen.
8. Bei Zweikanalgeräten:
Frequenzgang-Abgleich für Kanal 2 (CH II) vornehmen, analog Positionen 1 bis 7.
Die zugehörigen Anschlüsse und Regler sind:
Leitungs-Ausgang (36)
Leitungs-Eingang (35)
Regler TREBLE/SLOW (33)
Regler BASS/SLOW (27)

5.4.9**Balancing of recording frequency response (SLOW)**

1. Switch machine to slow tape speed.
2. Connect audio-frequency millivoltmeter to line output channel 1 (16) (CH I).
3. Connect audio-frequency generator to line input channel 1 (15) (CH I).
Level: 20 dB below reference level.
4. Mount new, unrecorded tape of desired quality and start machine in record mode.
5. Perform treble correction with TREBLE/SLOW control (13), board RECORD (CH I).
6. Vary audio-frequency generator at lower frequency range (30 ... 100 Hz).
7. Perform bass correction with BASS/SLOW control (7), board REPROD AMP (CH I). Adjust for linear output level .
8. For two-channel machines:
Balance frequencies for channel 2 (CH II) analogous to steps 1 to 7.
The associated connections and controls are as follows.
Line output (36)
Line input (35)
BASS/SLOW control (33)
TREBLE/SLOW control (27).

5.4.10 Frequenzgang "über Band" kontrollieren (FAST)

Achtung:

Der Frequenzgang muss so eingestellt sein, dass er im entsprechenden Toleranzfeld des Datenblattes liegt. Ist dies nicht der Fall, müssen die Einstellungen Kapitel 5.4.8 korrigiert werden.

1. Gerät auf schnelle Bandgeschwindigkeit schalten.
2. Tonfrequenz-Millivoltmeter an Leitungsausgang Kanal 1 (16) (CH I) anschliessen.
3. Neuwertiges, leeres Band der gewünschten Bandsorte auflegen.
4. Tonfrequenz-Generator an Leitungseingang Kanal 1 (15) (CH I) anschliessen.
Pegel: 20 dB unter Bezugspegel
5. Gerät auf Aufnahme starten.
6. Tonfrequenz-Generator innerhalb des gesamten spezifizierten Tonspektrums durchstimmen, die positiven und die negativen Abweichungen kontrollieren.
7. Bei Zweikanalgeräten:
Frequenzgang-Kontrolle für Kanal 2 (CH II) vornehmen, analog Positionen 1 bis 6.
Die zugehörigen Anschlüsse sind:
Leitungsausgang (36)
Leitungseingang (35)

5.4.11 Frequenzgang "über Band" kontrollieren (SLOW)

Achtung:

Der Frequenzgang muss so eingestellt sein, dass er im entsprechenden Toleranzfeld des Datenblattes liegt. Ist dies nicht der Fall, müssen die Einstellungen Kapitel 5.4.9 korrigiert werden.

1. Gerät auf schnelle Bandgeschwindigkeit schalten.
2. Tonfrequenz-Millivoltmeter an Leitungsausgang Kanal 1 (16) (CH I) anschliessen.
3. Neuwertiges, leeres Band der gewünschten Bandsorte auflegen.
4. Tonfrequenz-Generator an Leitungseingang Kanal 1 (15) (CH I) anschliessen.
Pegel: 20 dB unter Bezugspegel
5. Gerät auf Aufnahme starten.

5.4.10 Frequency-response "over all" (FAST)

Caution:

The frequency response must be adjusted to remain within the corresponding tolerance range of the specification sheet. If this should not be possible, the adjustments in chap. 5.4.8 must be corrected.

1. Switch machine to fast tape speed.
2. Connect audio-frequency millivoltmeter to line output channel 1 (16) (CH I).
3. Mount new, unrecorded tape of the desired quality.
4. Connect audio-frequency generator to line input channel 1 (15) (CH I).
Level: 20 dB below reference level.
5. Start machine in record mode.
6. Turn audio-frequency generator throughout the entire audio-frequency range according to specifications. Check positive and negative deviations.
7. For two-channel machines:
Also check frequency response for channel 2 (CH II) analogous to steps 1 – 6.
The associated connection points are:
Line output (36)
Line input (35).

5.4.11 Frequency-response "over all" (SLOW)

Caution:

The frequency response must be adjusted to remain within the corresponding tolerance range of the specification sheet. If this should not be possible, the adjustments in chap. 5.4.9 must be corrected.

1. Switch machine to slow tape speed.
2. Connect audio-frequency millivoltmeter to line output channel 1 (16) (CH I).
3. Mount new, unrecorded tape of the desired quality.
4. Connect audio-frequency generator to line input channel 1 (15) (CH I).
Level: 20 dB below reference level.
5. Start machine in record mode.

Bandtyp	7,5"	15"	30"
	dB	dB	dB
3M 202	5	4	2
3M 206	5,5	3	1,5
3M 262	6	3	1,5
Ampex Grand Master	6,5	3,5	2
Ampex 406	5	3	1,5
EMI 817	6,5	4	2
AGFA PER 525	6	3	1,5
AGFA PEM 468	6	3,5	2
BASF SPR 50LH	5,5	3,5	1,5
3M 250	6	3,5	2
3M 256	6,5	3,5	2
BASF LGR 30P	6	4	2
Pyral CJ90	6,5	3,5	2

△E 10kHz

Fig. 6.20

6. Tonfrequenz-Generator innerhalb des gesamten spezifizierten Tonspektrums durchstimmen, die positiven und die negativen Abweichungen kontrollieren.
7. Bei Zweikanalgeräten: Frequenzgang-Kontrolle für Kanal 2 (CH II) vornehmen, analog Positionen 1 bis 6. Die zugehörigen Anschlüsse sind: Leitungsausgang (36) Leitungseingang (35)
6. Turn audio-frequency generator throughout the entire audio-frequency range according to specifications. Check positive and negative deviations.
7. For two-channel machines: Also check frequency response for channel 2 (CH II) analogous to steps 1 – 6. The associated connection points are: Line output (36) Line input (35).

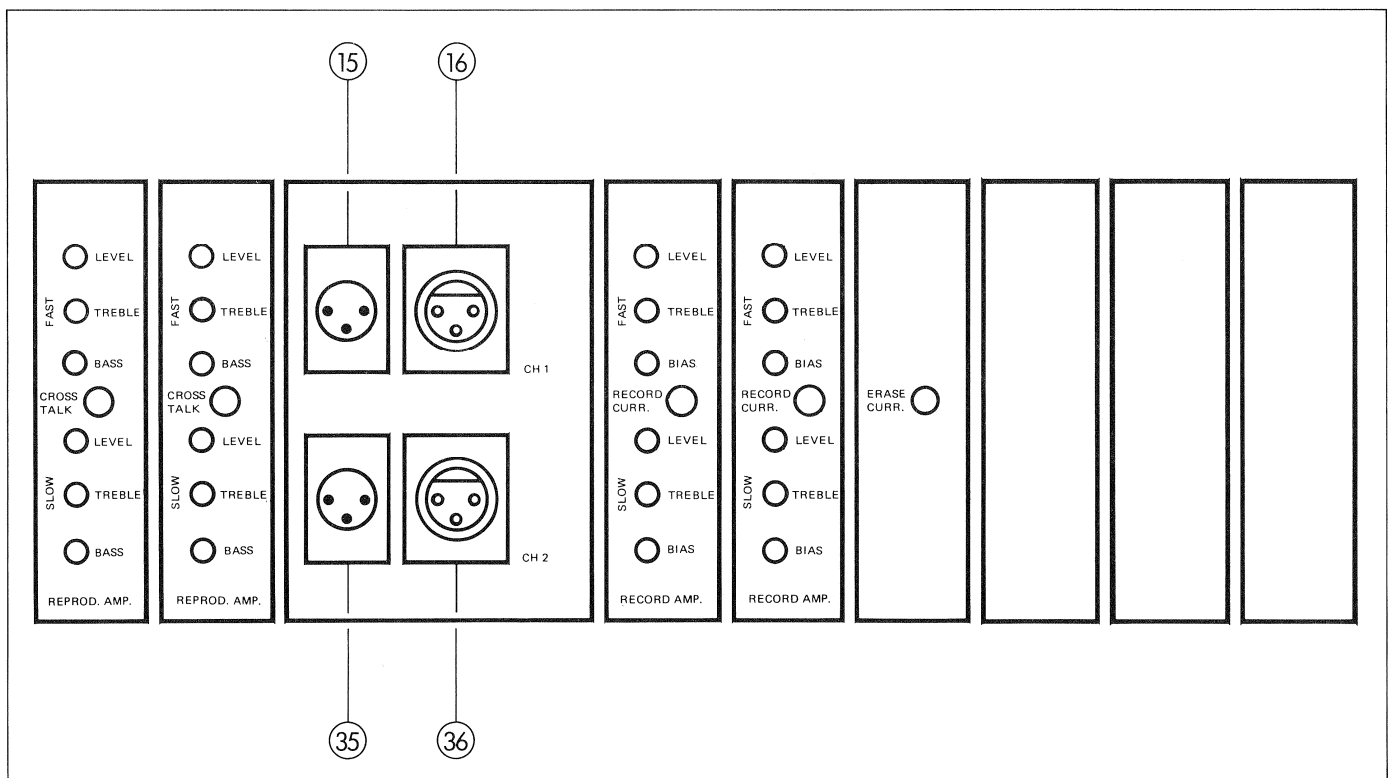

Fig. 5.21

Anmerkung:

Nach der Frequenzeinstellung bei schneller und langsamer Bandgeschwindigkeit sind die Pegelinstellungen der Aufnahmeverstärker Kapitel 5.4.2/5.4.3 zu kontrollieren und ggf. nachjustieren.

Liegt der Frequenzgang nicht innerhalb der garantierten Daten, so sind zunächst die folgenden Punkte zu überprüfen:

- Tonköpfe verschmutzt oder magnetisiert
- Spalteinstellung des Aufnahmekopfes nicht korrekt.
- Aufnahme-Pegel für die verwendete Bandsorte zu hoch; das Band arbeitet bei hohen Frequenzen im Sättigungsbereich.
- Vormagnetisierungseinstellung nicht korrekt durchgeführt oder falsche Einstellung für die gewählte Bandsorte.
- Höhen-Einstellung (TREBLE) nicht korrekt.

Note:

After adjusting the frequency response for fast and slow tape speeds, the level settings of the record amplifiers (chap. 5.4.2/5.4.3) must be rechecked and if necessary adjusted.

If the frequency range does not fall within the specifications, the following items should be rechecked:

- Heads dirty or magnetized
- Azimuth of record head set incorrectly
- Recording level too high for the type of tape used. The tape approaches saturation level.
- Bias setting incorrect or setting does not match the type of tape used.
- Treble setting incorrect.

5.4.12 Einstellen der Übersprechkompensation

5.4.12 Adjustment of the crosstalk compensation

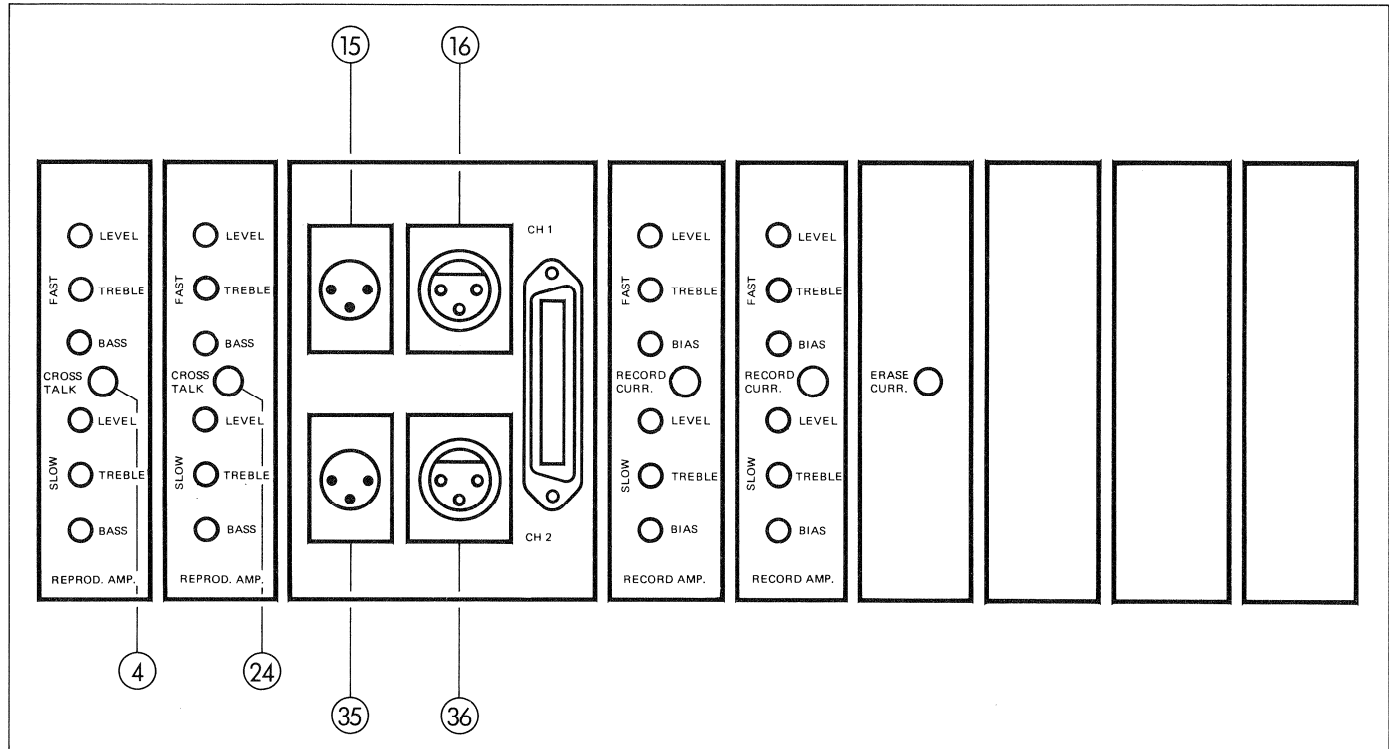

Fig. 5.22

Die nachfolgenden Einstellungen müssen mit einem selektiven Messgerät durchgeführt werden.

The following adjustments must be performed with a selective measuring device.

- | | |
|--|---|
| <p>1. Gerät auf schnelle Bandgeschwindigkeit schalten.</p> <p>2. Tonfrequenz-Generator an Leitungs-Eingang Kanal 1 (15) (CH I) anschliessen.
Pegel: Bezugspegel
Frequenz: 3 kHz</p> <p>3. Frequenz-Analysator an Leitungs-Ausgang Kanal 2 (36) (CH II) anschliessen.</p> <p>4. Neuwertiges, leeres Band der gewünschten Bandsorte auflegen und auf Aufnahme starten.</p> <p>5. Mit Regler CROSSTALK (4), Einschub REPROD AMP (CH I), Übersprechen auf Minimum-Anzeige am Frequenz-Analysator einstellen.</p> <p>6. Übersprechen in umgekehrter Reihenfolge: Tonfrequenz-Generator an Leitungs-Eingang Kanal 2 (35) (CH II). Frequenz-Analysator an Leitungs-Ausgang Kanal 1 (16) (CH I). Regler CROSSTALK (24) auf REPROD AMP (CH II) auf Minimum stellen (analog Positionen 2 bis 5).</p> | <p>1. Switch machine to fast speed.</p> <p>2. Connect audio-frequency generator to line input channel 1 (15) (CH I).
Level: reference level
Frequency: 3 kHz</p> <p>3. Connect harmonic analyzer to line output channel 2 (36) (CH II).</p> <p>4. Mount new, unrecorded tape of the desired quality and start machine in record mode.</p> <p>5. Adjust crosstalk for minimum reading at harmonic analyzer by turning CROSS-TALK (4) control board REPROD AMP (CH I).</p> <p>6. Crosstalk in reverse sequence: Connect audio-frequency generator to line input channel 2 (35) (CH II). Connect harmonic analyzer to line output channel 1 (16) (CH I). Adjust CROSSTALK control (24) on board REPROD AMP (CH II) for minimum reading (analogous to steps 2 – 5).</p> |
|--|---|

5.5 A80 R MIT MONO-STEREO UMSCHALTER

5.5 A80 R EQUIPPED WITH MONO-STEREO SELECTOR

Vor Beginn dieses Kapitels sind die Einstellungen nach Kapitel 5.1/5.2 durchzuführen.

Before beginning with this chapter, perform all adjustments specified in chap. 5.1/5.2.

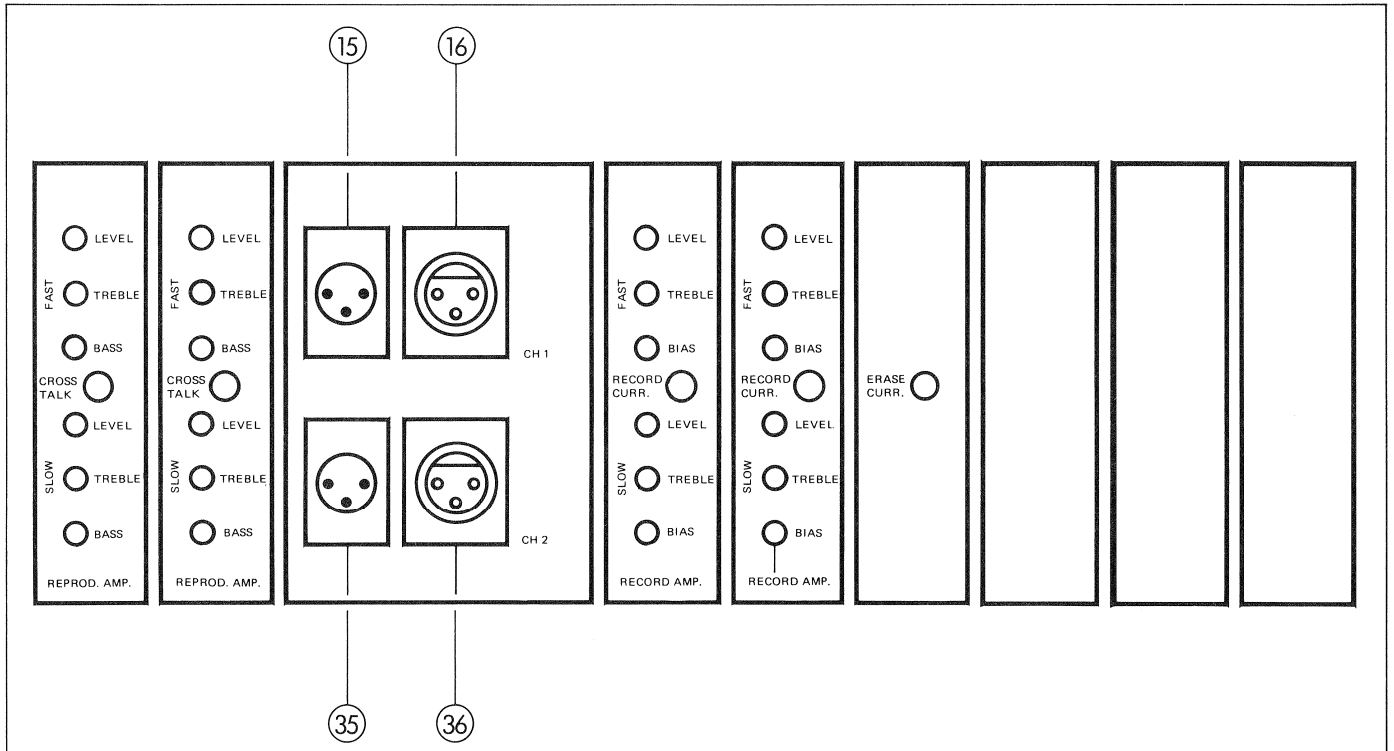

Fig. 5.23

5.5.1 Pegeleinstellen des Aufnahme- und Wiedergabe- verstärkers

1. Anschlussfeld herausziehen. Verlängerungssteckkarte (1.080.940) einsetzen und Anschlussfeld auf Verlängerungssteckkarte aufstecken.
2. Gerät auf schnelle Bandgeschwindigkeit schalten.
3. Entsprechendes Messband auflegen.
4. MONO-STEREO Umschalter (20) auf MONO schalten.
5. Tonfrequenz-Millivoltmeter an Leitungsausgang Kanal 1 (16) (CH I) anschliessen.
6. Messband im Abschnitt "Bezugspegel" auf Wiedergabe starten.
7. Am Regler REPRODUCE (38) auf der Steckkarte des Anschlussfeldes 1,1 dB unter Bezugspegel einstellen (Trennspurverlust).

5.5.1 Level adjustment of record/reproduce amplifier

1. Pull out connection panel. Install extension board (1.080.940) and mount connection panel on extension board.
2. Switch machine to fast tape speed.
3. Mount appropriate test tape.
4. Switch MONO/STEREO selector (20) to MONO.
5. Connect audio-frequency millivoltmeter to line input channel 1 (16) (CH I).
6. Play test tape at "reference level" section.
7. Adjust REPRODUCE control (38) on connection panel board to obtain a reading of 1.1 dB below reference level (guard track loss).

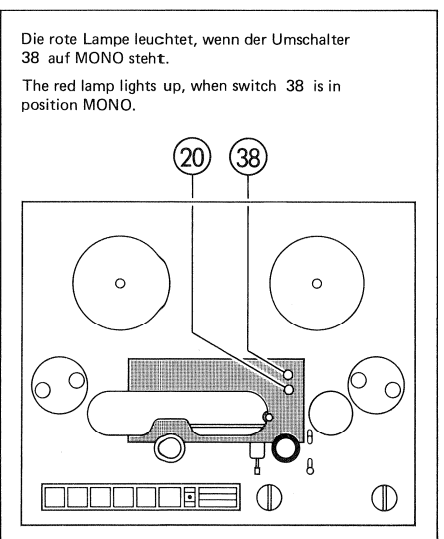

Fig. 5.24

- | | |
|---|---|
| <p>8. Messband von Gerät abheben. Neuwertiges, leeres Band der gewünschten Bandsorte auflegen.</p> <p>9. Tonfrequenz-Generator an Leitungseingang Kanal 1 (15) (CH I) anschliessen.
Frequenz: 1 kHz
Pegel: Bezugspegel</p> <p>10. Gerät auf Aufnahme starten.</p> <p>11. Am Regler RECORD (39) auf der Steckkarte des Anschlussfeldes auf Bezugspegel einstellen.</p> <p>12. Diese Einstellungen sind nur für eine Bandgeschwindigkeit auszuführen.</p> | <p>8. Remove test tape from unit. Mount new, unrecorded tape of the desired quality.</p> <p>9. Connect audio-frequency generator to line input channel 1 (15) (CH I).
Frequency: 1 kHz
Level: Reference level.</p> <p>10. Start machine in record mode.</p> <p>11. Adjust RECORD control (39) on connection panel board to obtain reference level.</p> <p>12. These adjustments need only be made for one tape speed.</p> |
|---|---|

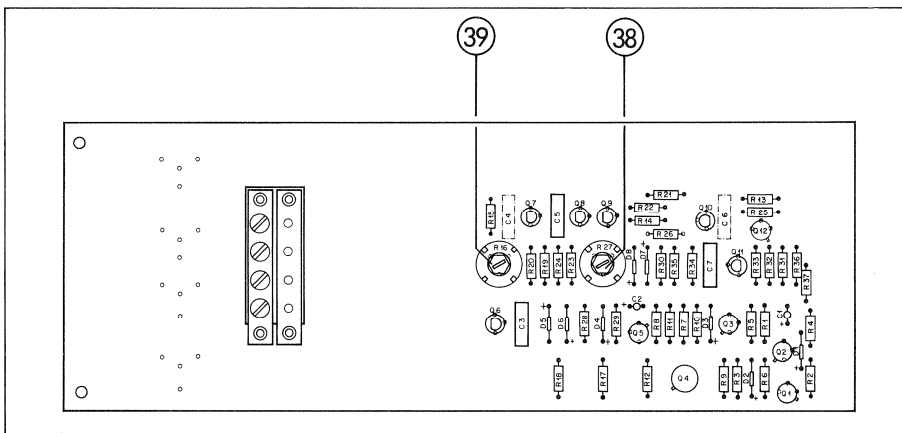

Fig. 5.25

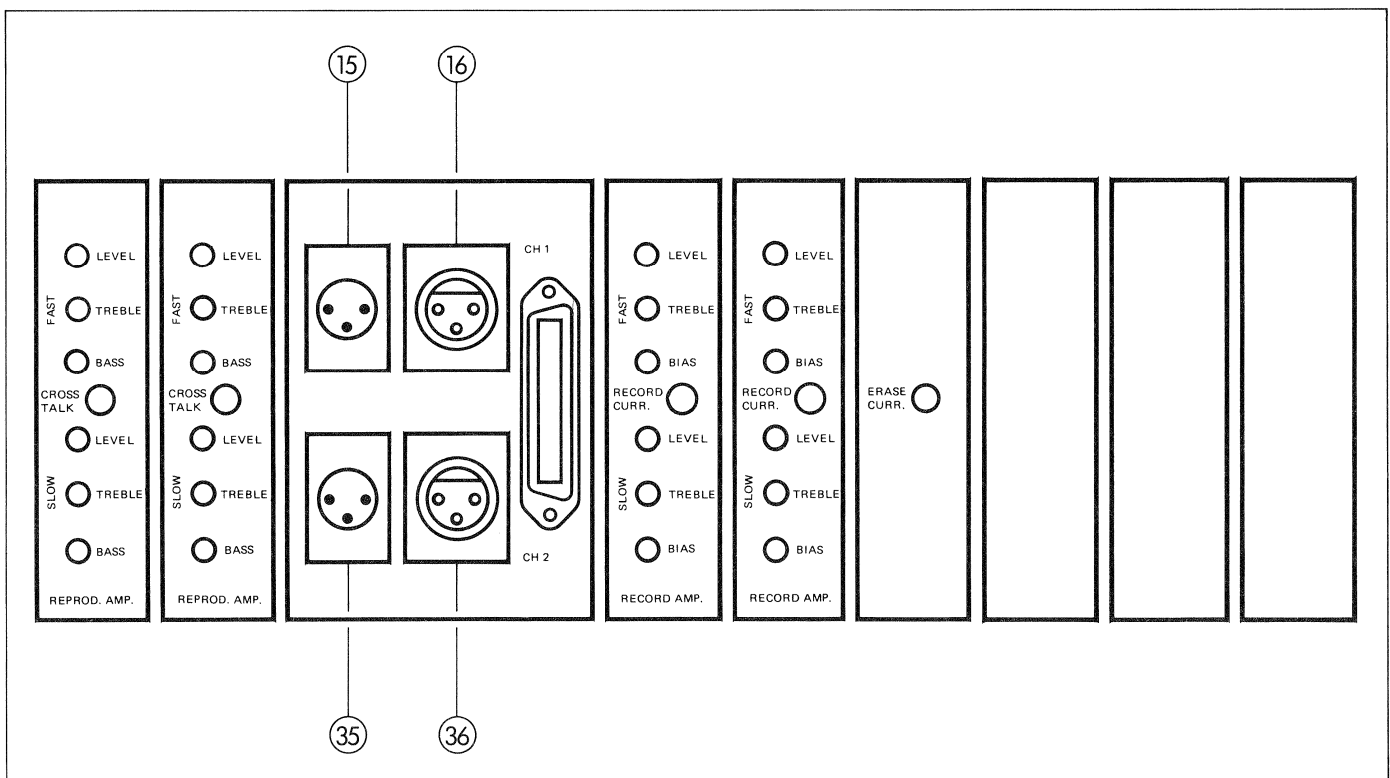

Fig. 5.26

**5.6
A80 R VU-METER PANEL VERSION**

Vor Beginn dieses Kapitels sind die Einstellungen nach Kapitel 5.1/5.2 durchzuführen.

Anmerkung:

Ist die VU-Meter Kontrolleinheit vorübergehend entfernt worden, so muss anstelle des VU-Meter Kabels, am Anschlussfeld ein Spezialstecker angebracht werden. Dieser enthält die nötige Beschriftung um trotzdem ein korrektes Funktionieren des Gerätes zu gewährleisten.

**5.6
A80 R VU-METER PANEL VERSION**

Before beginning with this chapter, all settings according to chap. 5.1/5.2 must have been performed.

Note:

If the VU-meter control unit has been temporarily removed, a special plug must be inserted in the connection panel in place of the VU-meter cable. This plug supplies the necessary interconnections to continue proper functioning of the machine.

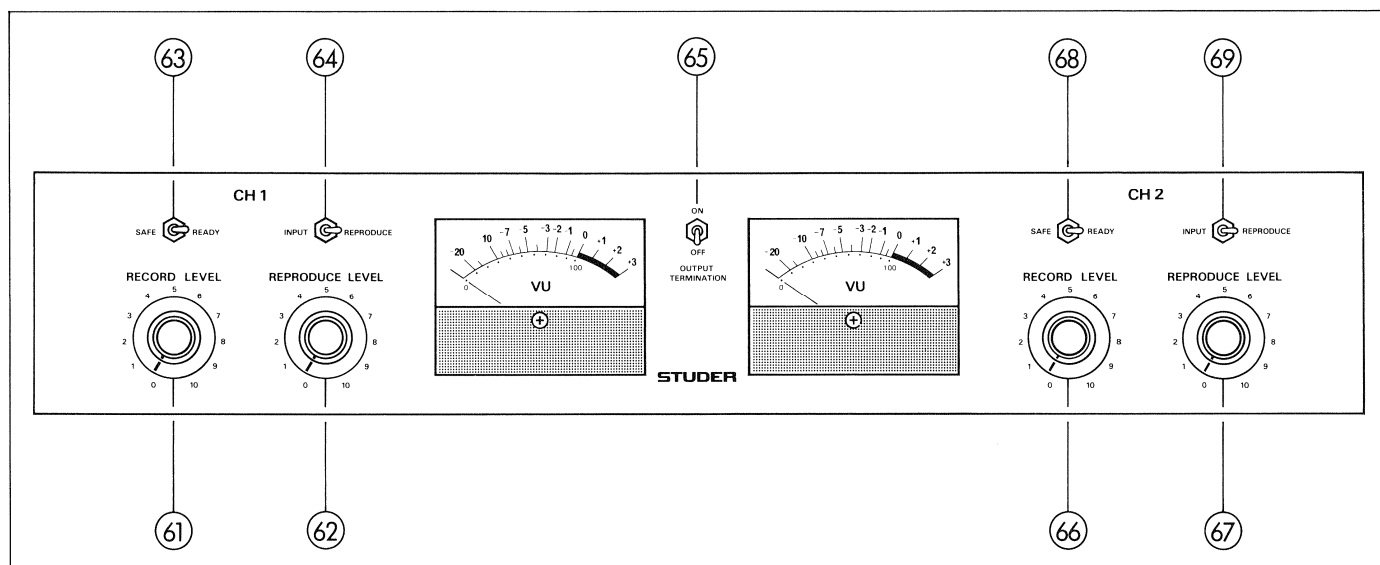

Fig. 5.27

**5.6.1
Allgemeines**

Kanal 1 (CH I)

- (61) Aufnahme-Regler
- (62) Wiedergabe-Regler
- (63) SAFE-READY Schalter
- (64) MONITOR Schalter
(Vorband-Hinterband)

Kanal 2 (CH II)

- (66) Aufnahme-Regler
- (67) Wiedergabe-Regler
- (68) SAFE-READY Schalter
- (69) MONITOR Schalter
(Vorband-Hinterband)
- (65) Leitungsabschluss-Schalter

**5.6.1
General**

Channel 1 (CH I)

- (61) Record level
- (62) Reproduce level
- (63) SAFE-READY switch
- (64) MONITOR switch
(AB/BA monitoring)

Channel 2 (CH II)

- (66) Record level
- (67) Reproduce level
- (68) SAFE-READY switch
- (69) MONITOR switch
(AB/BA monitoring)
- (65) Line termination switch

Kontrollen:

- Ist auf dem VU-Meter Print der Leitungspegel richtig eingestellt?
- Ist der Ausgang (VU-Meter Print) der Norm entsprechend (CCIR 200 Ohm / NAB 600 Ohm) abgeschlossen?
- Sind die Aufnahme- und Wiedergabeverstärker den entsprechenden Normen angepasst?

Checks:

- Is the level of the VU-meter print correctly set?
- Is the output (VU-meter print) terminated with the proper resistance (CCIR 200 ohms/ NAB 600 ohms)?
- Are the recording and reproducing amplifiers set for the corresponding standard?

5.6.2

Wiedergabeeinstellungen

Die Tonköpfe und die Bandführungselemente sorgfältig reinigen und entmagnetisieren.

5.6.2

Reproduce level adjustments

Carefully clean and demagnetize the heads and the tape guidance elements.

5.6.3

Positionieren der Pegelregler

1. Gerät einschalten.
2. SAFE-READY Schalter (63) auf SAFE.
3. MONITOR-Schalter (64) auf INPUT.
4. Schalter TERMINATION (65) auf ON.
5. Tonfrequenz-Generator an Leitungseingang Kanal 1 (15) (CH I) anschliessen.
Frequenz: entsprechender Bezugspegel
Pegel: Leitungspegel

5.6.3

Adjustment of level control

1. Power on machine.
2. Turn SAFE-READY switch (63) to SAFE position.
3. Turn MONITOR switch (64) to INPUT position.
4. Set TERMINATION switch (65) to ON
5. Connect audio-frequency generator to line input channel 1 (15) (CH I).
Frequency: corresponding reference level
Level: line level

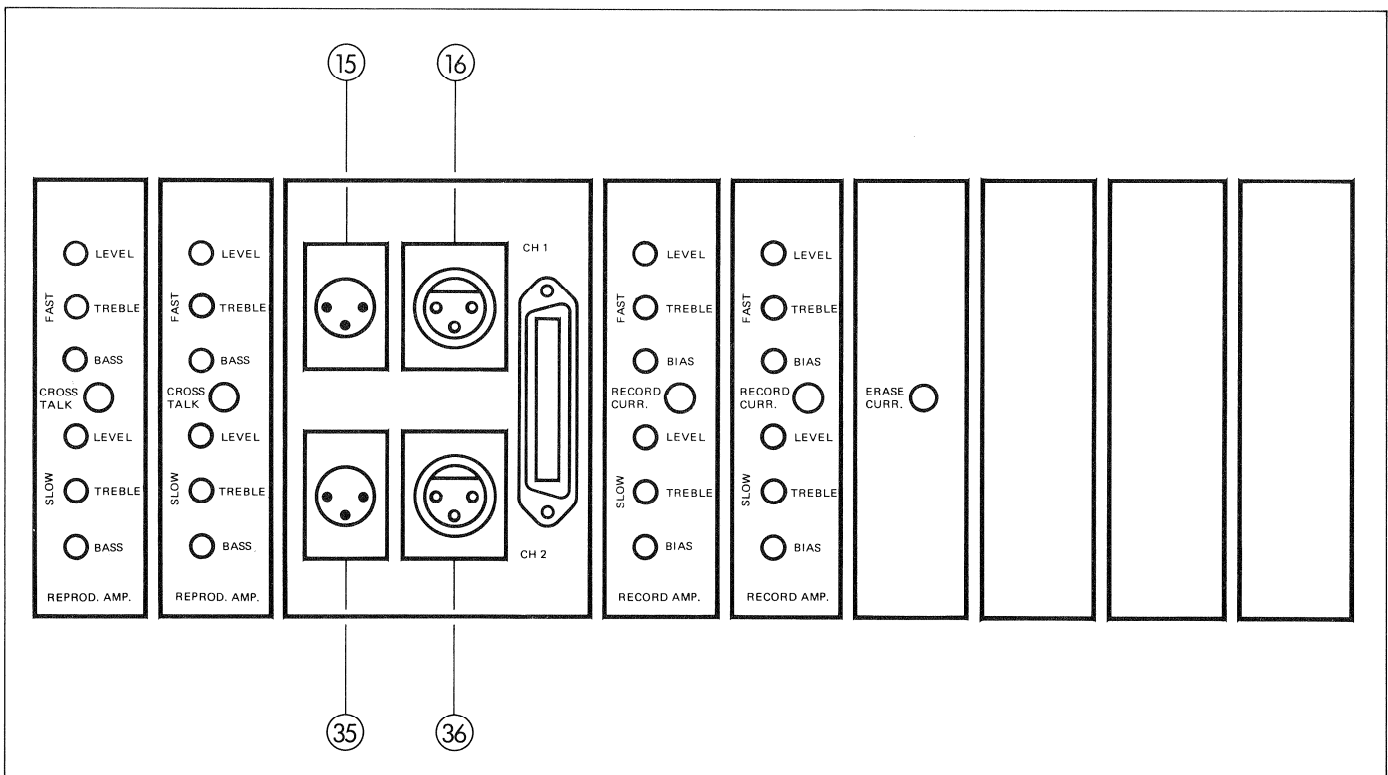

Fig. 5.29

- | | |
|--|--|
| <p>6. Regler RECORD LEVEL (61) so einstellen, dass sich am VU-Meter eine Anzeige von 0 VU ergibt.
Markierungs-Ring auf diesen Wert fixieren.</p> <p>7. Regler REPRODUCE LEVEL (62) auf die gleiche Position stellen wie Regler RECORD LEVEL (61).
Markierungs-Ring auf diesen Wert fixieren.</p> <p>8. Einstellungen für Kanal 2 (CH II) vornehmen, analog Positionen 1 bis 7.
Die zugehörigen Schalter, Anschlüsse und Regler sind:
SAFE-READY Schalter (68)
MONITOR Schalter (69)
Leitungs-Eingang (35)
Regler RECORD LEVEL (66)
Regler REPRODUCE LEVEL (67)</p> | <p>6. Adjust RECORD LEVEL control (61) to obtain a VU-meter reading of 0 VU.
Fix marker ring with above value.</p> <p>7. Adjust REPRODUCE LEVEL (62) to same position as RECORD LEVEL (61).
Fix marker ring in this position.</p> <p>8. Make settings for channel 2 (CH II) analogous to steps 1 – 7.
The associated switches, connections and controls are:
SAFE-READY switch (68)
MONITOR switch (69)
Line input (35)
RECORD LEVEL control (66)
REPRODUCE LEVEL control (67)</p> |
|--|--|

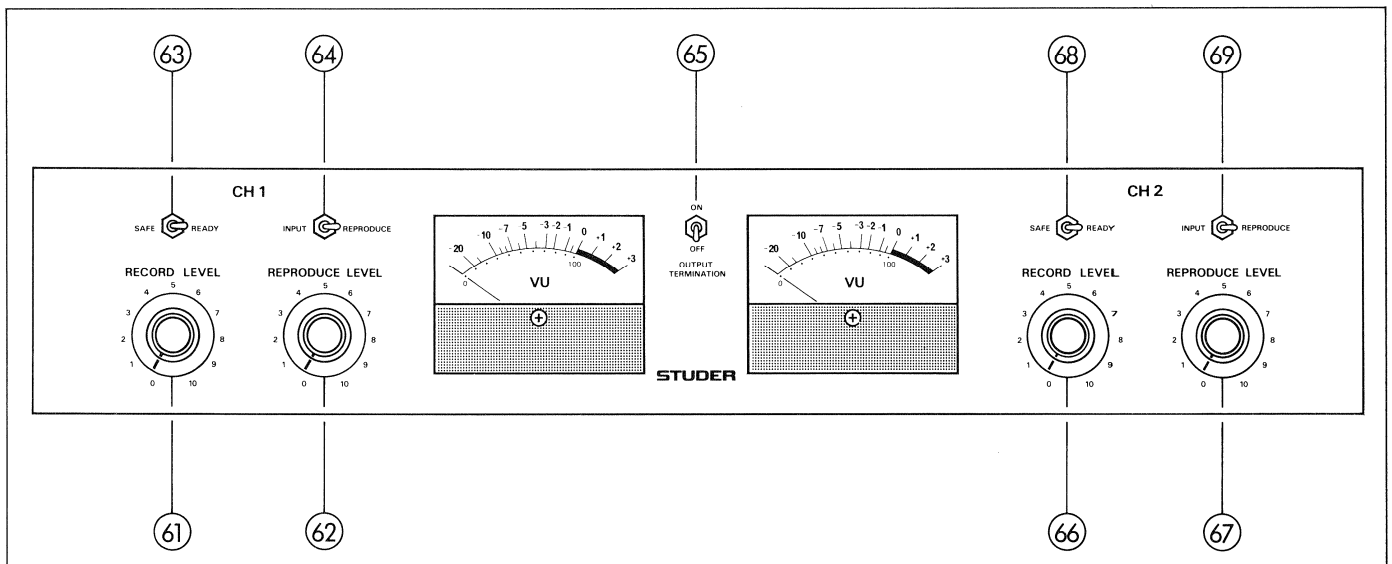

Fig. 5.30

5.6.4 Pegeleinstellen der Wiedergabeverstärker (FAST)

1. Gerät einschalten, schnelle Bandgeschwindigkeit.
2. SAFE-READY Schalter (63) auf SAFE.
3. MONITOR-Schalter (64) auf REPRODUCE.
4. Schalter TERMINATION (65) auf ON.
5. Entsprechendes Messband auflegen und auf Wiedergabe starten im Abschnitt "Bezugspegel".
6. Regler LEVEL/FAST (1), Einschub REPROD AMP (CH I), auf eine VU-Meter Anzeige von 0 VU einstellen.
7. Pegeleinstellung für Kanal 2 (CH II) vornehmen, analog Positionen 1 bis 6. Die zugehörigen Schalter und Regler sind: SAFE-READY Schalter (68) MONITOR Schalter (69) Regler LEVEL/FAST (21)

5.6.4 Adjustment of reproduce amplifier level (FAST)

1. Switch machine to fast tape speed.
2. Turn SAFE-READY switch (63) to SAFE.
3. Turn MONITOR switch (64) to REPRODUCE.
4. Turn TERMINATION switch (65) to ON
5. Mount corresponding test tape and play tape in section "reference level".
6. Adjust LEVEL/FAST control (1) on REPROD AMP (CH I) board to a VU-meter reading of 0 VU.
7. Adjust level for channel 2 (CH II) analogous to steps 1 – 6. The associated switches and controls are: SAFE-READY switch (68) MONITOR switch (69) LEVEL/FAST control (21)

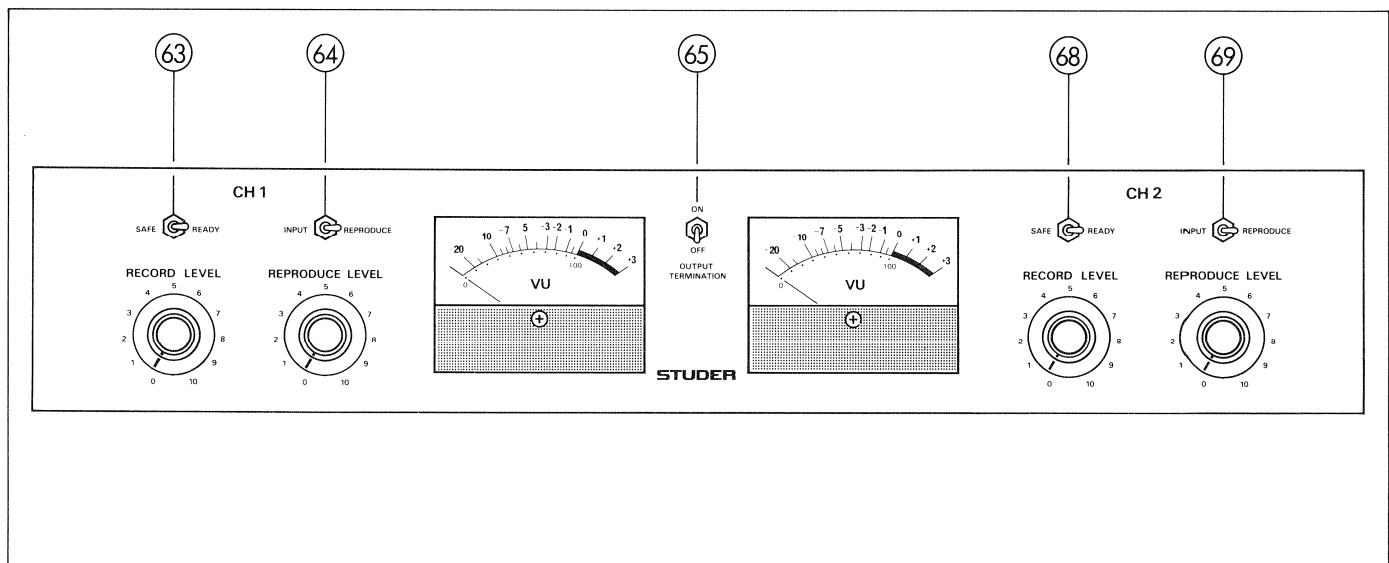

Fig. 5.30

5.6.5 Pegeleinstellen der Wiedergabeverstärker (SLOW)

1. Gerät auf langsame Bandgeschwindigkeit einstellen.
2. SAFE-READY Schalter (63) auf SAFE.
3. MONITOR Schalter (64) auf REPRODUCE.
4. Schalter TERMINATION (65) auf ON.

5.6.5 Adjustment of reproduce amplifier level (SLOW)

1. Switch machine to slow tape speed.
2. Turn SAFE-READY switch (63) to SAFE.
3. Turn MONITOR switch (64) to REPRODUCE.
4. Turn TERMINATION switch (65) to ON

- | | |
|---|--|
| <p>5. Entsprechendes Messband auflegen und auf Wiedergabe starten im Abschnitt "Bezugspegel".</p> <p>6. Regler LEVEL/SLOW (5), Einschub REPROD AMP (CH I), auf eine VU-Meter Anzeige von 0 VU einstellen.</p> <p>7. Pegelinstellung für Kanal 2 (CH II) vornehmen, analog Positionen 1 bis 6. Die zugehörigen Schalter und Regler sind: SAFE-READY Schalter (68) MONITOR Schalter (69) Regler LEVEL/SLOW (25)</p> | <p>5. Mount corresponding test tape and play tape in section "reference level".</p> <p>6. Adjust LEVEL/SLOW control (5) on REPROD AMP (CH I) board to a VU-meter reading of 0 VU.</p> <p>7. Adjust level for channel 2 (CH II) analogous to steps 1 – 6. The associated switches and controls are: SAFE-READY switch (68) MONITOR switch (69) LEVEL/SLOW control (25).</p> |
|---|--|

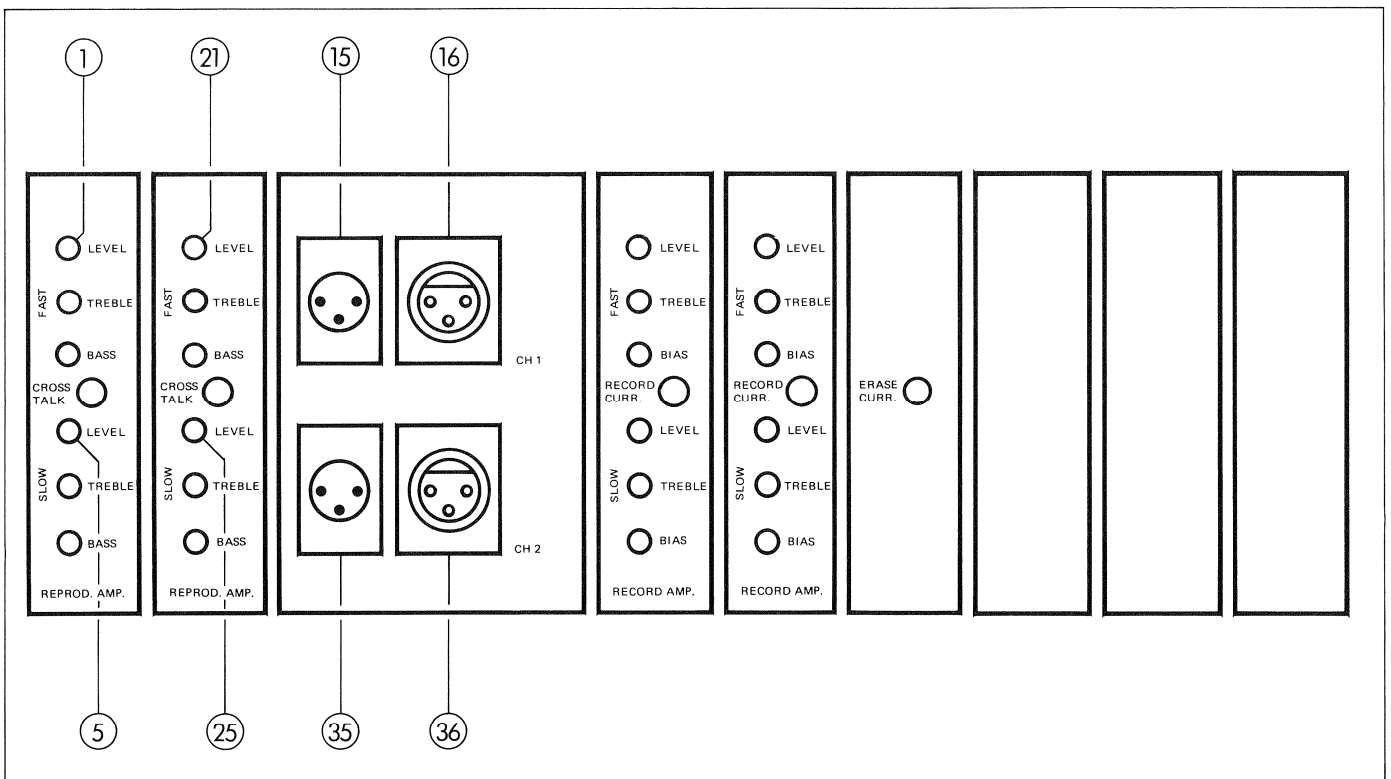

Fig. 5.29

5.6.6**Wiedergabekopf Spalteinstellung (AZIMUT)**

Nur für MONO-Geräte

1. Gerät auf schnelle Bandgeschwindigkeit schalten.
2. SAFE-READY Schalter (63) auf SAFE.
3. MONITOR Schalter (64) auf REPRODUCE.
4. Schalter TERMINATION (65) auf ON.
5. Tonfrequenz-Millivoltmeter an Leitungsausgang (16) anschliessen.
6. Entsprechendes Messband auflegen im Abschnitt "Spalteinstellung 10 kHz" auf Wiedergabe starten.
7. Mit der Spaltjustierschraube (18) (siehe Fig. 5.31) den Wiedergabekopf auf Pegelmaximum justieren.
8. Nach massiver Justierung, bzw. grober Abweichung des Pegels müssen die Punkte 5 und 6 der Abschnitte 5.6.3 und 5.6.4 (Pegeleinstellung der Wiedergabeverstärker) wiederholt werden.

6.6.5**Adjustment of reproduce amplifier level (SLOW)**

For MONO machines only:

1. Switch machine to fast speed.
2. Turn SAFE-READY switch (63) to SAFE.
3. Turn MONITOR switch (64) to REPRODUCE.
4. Turn TERMINATION switch (65) to ON.
5. Connect audio-frequency millivoltmeter to line output (16).
6. Mount corresponding test tape and play section "azimuth" adjustment 10 kHz.
7. Adjust azimuth to obtain maximum level by turning azimuth adjustment screw (18) (see Fig. 5.31).
8. If the adjustment was significant, i.e. the level deviation was considerable, steps 5 and 6 of chapter 5.6.3 and 5.6.4 (level adjustment of reproducing amplifiers) must be repeated.

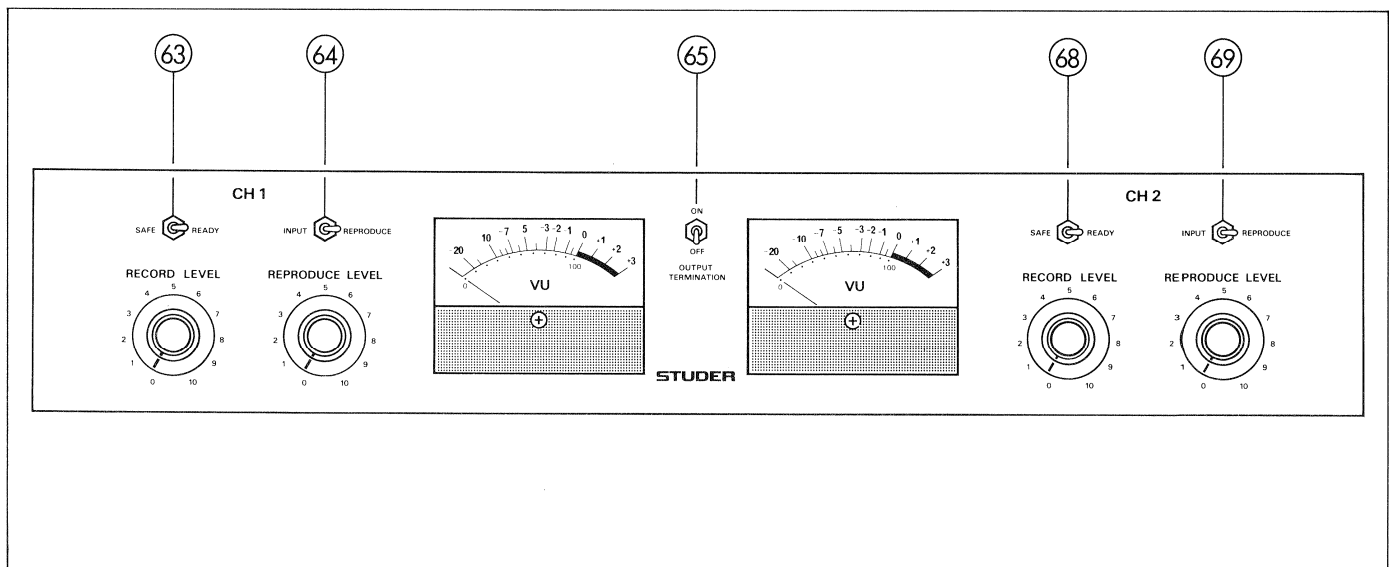

Fig. 5.30

5.6.7**Wiedergabekopf Spalteinstellung (AZIMUT)**

Für STEREO- oder 2-Spur-Geräte

Die folgende Phaseinstellung kann mit einem 2-Kanal-Oszillographen (Abschnitt A) oder nach der Phasen-Methode (Abschnitt B) durchgeführt werden. Die Wahl der Methode richtet sich nach den vorhandenen Messgeräten.

5.6.7**Azimuth adjustment for reproduce head**

For STEREO and two-track machines:

The following phase adjustment can be performed with a two-channel oscilloscope (Section A) or with the phase method (Section B). The method employed depends on the type of measuring instruments available.

- | | |
|--|---|
| 1. SAFE-READY Schalter (63) und (68) auf SAFE. | 1. SAFE-READY switches (63) and (68) to SAFE. |
| 2. MONITOR Schalter (64) und (69) auf REPRODUCE. | 2. MONITOR switches (64) and (69) to REPRODUCE. |
| 3. Schalter TERMINATION (65) auf ON. | 3. TERMINATION switch (65) to ON. |

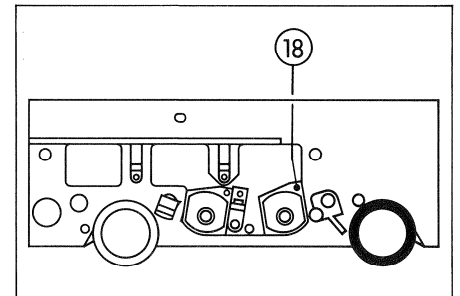

Fig. 5.31

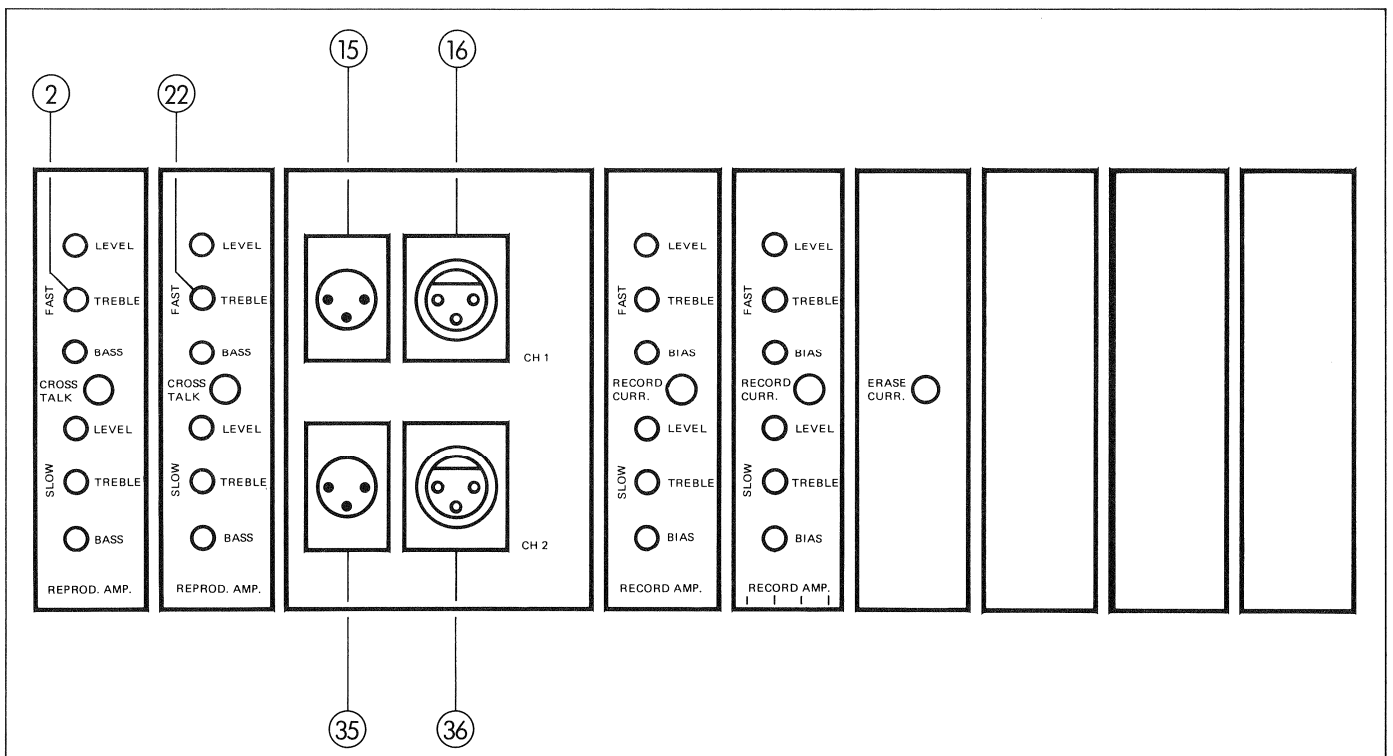

Fig. 5.32

A Messmethode mit 2-Kanal-Oszillographen

1. Gerät auf schnelle Bandgeschwindigkeit schalten.
2. 2-Kanal-Oszillograph an Leitungs-Ausgänge 1 und 2 (16) und (36) (CH I + CH II) anschliessen.
3. Entsprechendes Messband im Abschnitt "Spalteinstellung 10 kHz" auf Wiedergabe starten.
4. Die beiden Ausgangspegel des Gerätes auf identische Amplitude vorabgleichen. (Regler TREBLE/FAST (2) / (22) an den Einschüben REPROD AMP)
5. Wiedergabekopf mittels Spaltjustierschraube (18) Fig. 5.31 auf geringste Phasenwinkeldifferenz einstellen.

A Measuring method with 2-channel oscilloscope

1. Switch machine to fast speed.
2. Connect 2-channel oscilloscope to line-outputs 1 and 2 (16) and (36) (CH I + CH II).
3. Mount corresponding tape and play section "azimuth adjustment 10 kHz".
4. Pre-adjust the two output levels of the machine to identical amplitude. (TREBLE/FAST control (2) / (22) located on REPROD AMP boards).
5. Adjust azimuth setting by turning adjustment screw (18) Fig. 5.31 to obtain minimal phase angle difference.

B Phasenmethode

1. Gerät auf schnelle Bandgeschwindigkeit schalten.
2. Entsprechendes Testband im Abschnitt "Spalteinstellung 10 kHz" auf Wiedergabe starten.
3. Tonfrequenz-Millivoltmeter an Leitungsausgang Kanal 1 (16), nachher an den Leitungsausgang Kanal 2 (36) anschliessen. Mit den entsprechenden Reglern TREBLE/FAST (2) / (22) (Einschübe REPROD AMP) auf identische Ausgangspegel vorabgleichen.
4. Tonfrequenz-Millivoltmeter gegenphasig an die beiden Leitungsausgänge Kanal 1 (16) und Kanal 2 (36) (CH I + CH II) gemäss Fig. 5.33a anschliessen.
5. Wiedergabetonkopf mit der Spaltjustierschraube (18) auf Minimum-Anzeige abgleichen. Diesen Differenzpegel P_d ablesen und notieren (dB).
6. Tonfrequenz-Millivoltmeter gleichphasig an die beiden Leitungsausgänge Kanal 1 (16) und Kanal 2 (36) (CH I + CH II) gemäss Fig. 5.33b anschliessen.
7. Ablesen des Summenpegels P_s .
8. Für die Ermittlung des Phasenwinkels gemäss Fig. 5.35 ist die Pegeldifferenz $P_s - P_d$ zu bilden. Die vorhandene Phasenwinkel-differenz kann aus dieser Kurve herausgelesen werden.

5.6.8
Adjustment of reproduce frequency response (FAST)

1. Gerät auf schnelle Bandgeschwindigkeit schalten.
2. SAFE-READY Schalter (63) auf SAFE.
3. MONITOR Schalter (64) auf REPRODUCE.
4. Schalter TERMINATION (65) auf ON.
5. Tonfrequenz-Millivoltmeter an Leitungsausgang Kanal 1 (16) anschliessen.
6. Entsprechendes Messband auflegen und im Abschnitt "Frequenzgang" auf Wiedergabe starten.
7. Höhenkorrektur mit Regler TREBLE/FAST (2), Einschub REPROD AMP (CH I) vornehmen.

B Counter phase method

1. Switch machine to fast tape speed.
2. Mount corresponding tape and play section "azimuth adjustment 10 kHz".
3. Connect audio-frequency millivoltmeter to line output channel 1 (16) and subsequently to line output channel 2 (36). Pre-adjust corresponding TREBLE/FAST controls (2) / (22) (REPROD AMP board) to identical levels.
4. Connect audio-frequency millivoltmeter with reversed phasing to both line outputs of channel 1 (16) and channel 2 (36) (CH I + CH II) as shown in Fig. 5.33a.
5. Adjust azimuth with adjustment screw (18) to obtain minimum reading. Write down level difference P_d observed.
6. Connect audio-frequency millivoltmeter in phase to both line outputs channel 1 (16) and channel 2 (36) (CH I + CH II) as shown in Fig. 5.33b.
7. Read summary level P_s .
8. To determine the phase angle according to Fig. 5.35, the level difference $P_s - P_d$ is to be formed. The residual phase displacement angle can be read from the curve.

5.6.8
Wiedergabefrequenzgang Abgleich (FAST)

1. Switch machine to fast tape speed.
2. Turn SAFE-READY switch (63) to SAFE.
3. Turn MONITOR switch (64) to REPRODUCE.
4. Turn TERMINATION switch (65) to ON.
5. Connect audio-frequency millivoltmeter to line output channel 1 (16).
6. Mount corresponding test tape and play section "frequency response".
7. Adjust treble with TREBLE/FAST control (2) located on REPROD AMP board (CH I)

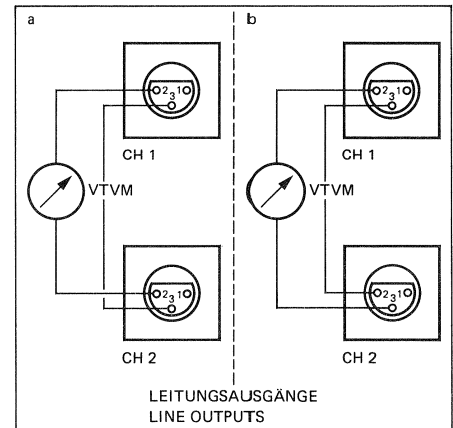

Fig. 5.33

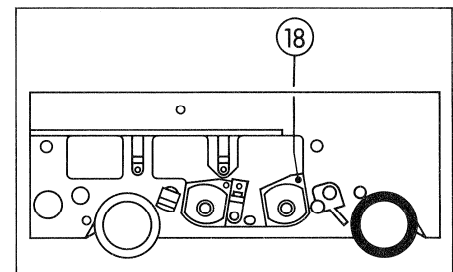

Fig. 5.31

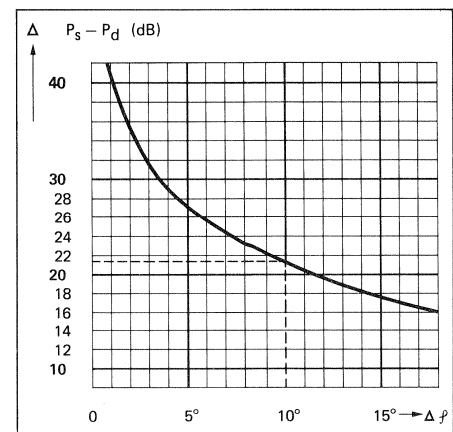

Fig. 5.35

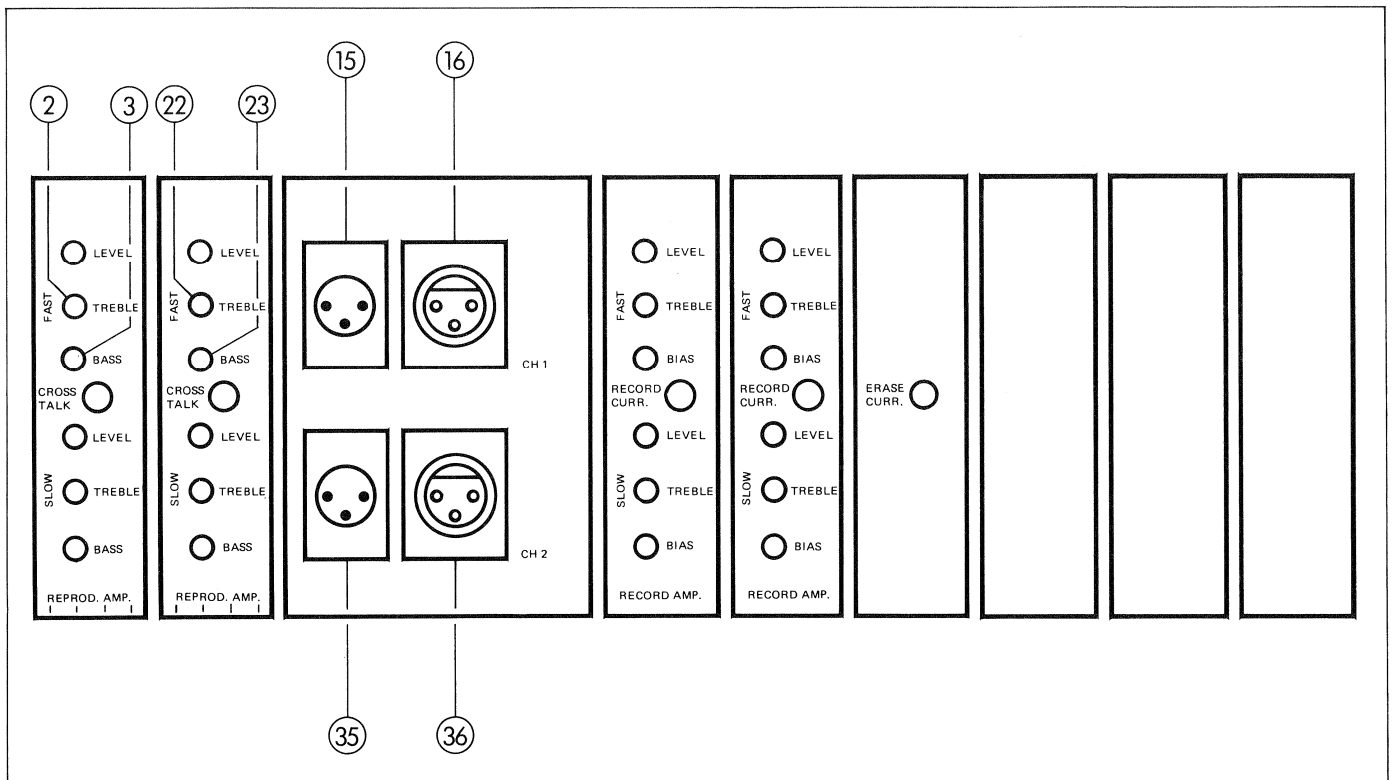

Fig. 5.36

8. Tiefenkorrektur mit Regler BASS/FAST (3), Einschub REPROD AMP (CH I) im unteren Tonfrequenzbereich (< 100 Hz) vornehmen.

Anmerkung:

Bei Verwendung eines Messbandes bei dem der Frequenzgang mit Vollpegel aufgezeichnet ist, kann der Abgleich mittels des VU-Meters anstelle des externen Millivoltmeters vorgenommen werden.

9. Frequenzgang-Abgleich für Kanal 2 (CH II) vornehmen, analog Positionen 1 bis 8. Die zugehörigen Schalter und Regler sind: SAFE-READY Schalter (68) MONITOR Schalter (69) Leitungs-Ausgang (36) Regler TREBLE/FAST (22) Regler BASS/FAST (23)

5.6.9**Wiedergabefrequenzgang Abgleich (SLOW)**

1. Gerät auf langsame Bandgeschwindigkeit schalten.
2. SAFE-READY Schalter (63) auf SAFE.
3. MONITOR Schalter (64) auf REPRODUCE.

8. Adjust lower frequency range (< 100 Hz) with BASS/FAST control (3) located on REPROD AMP board (CH I).

Note:

When using a test tape whose frequency range has been recorded at full level, the frequency response can be adjusted with the VU meter instead of an external millivoltmeter.

9. Adjust frequency response for channel 2 (CH II) analogous to steps 1 – 8. The associated switches and controls are: SAFE-READY switch (68) MONITOR switch (69) Line output (36) TREBLE/FAST control (22) BASS/FAST control (23)

5.6.9**Adjustment of reproduce frequency response (SLOW)**

1. Switch machine to slow tape speed.
2. Turn SAFE-READY switch (63) to S
3. Turn MONITOR switch (64) to REPRODUCE.

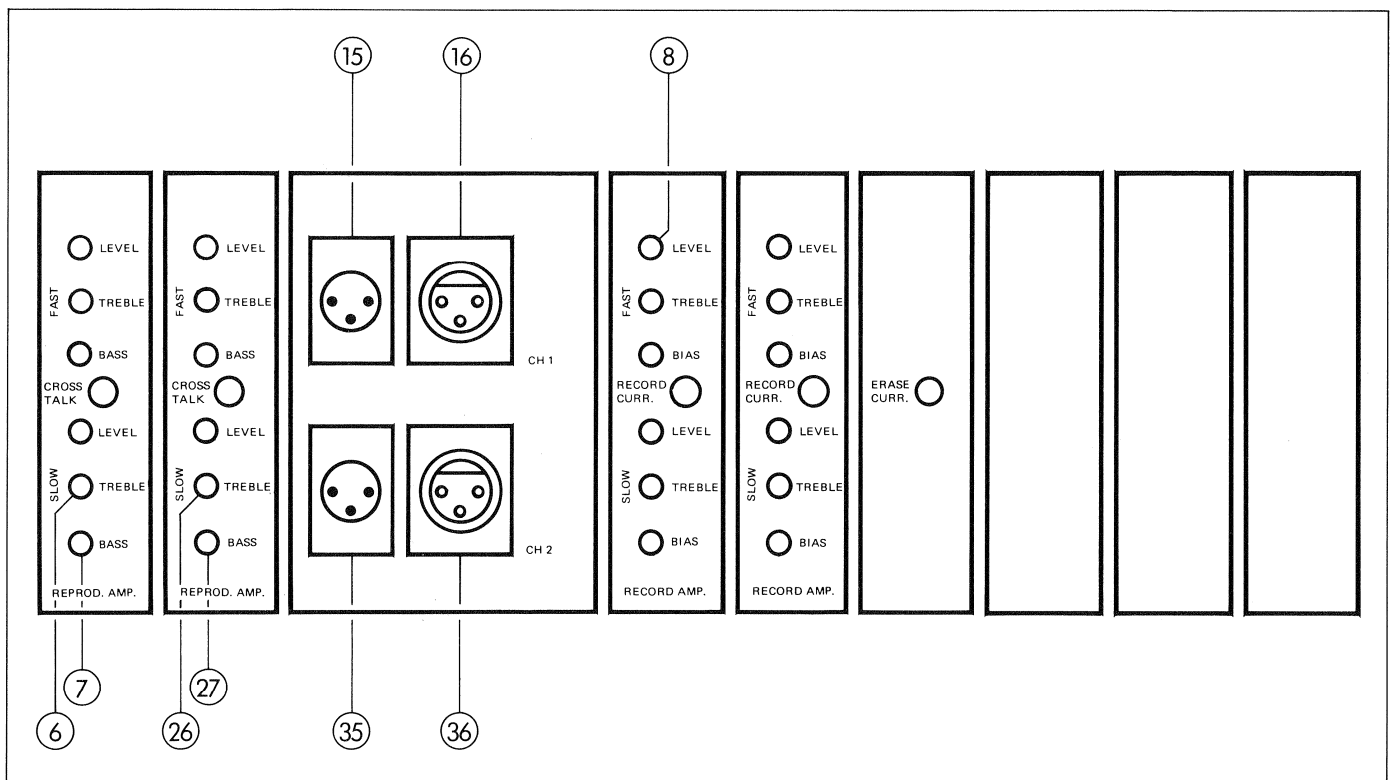

Fig. 5.37

- | | |
|---|---|
| 4. Schalter TERMINATION (65) auf ON. | 4. Turn TERMINATION switch (65) to ON. |
| 5. Tonfrequenz-Millivoltmeter an Leitungsausgang Kanal 1 (16) anschliessen. | 5. Connect audio-frequency millivoltmeter to line output channel 1 (16). |
| 6. Entsprechendes Messband auflegen und im Abschnitt "Frequenzgang" auf Wiedergabe starten. | 6. Mount corresponding test tape and play section "reference response". |
| 7. Höhenkorrektur mit Regler TREBLE/SLOW (6), Einschub REPROD AMP (CH I) vornehmen. | 7. Adjust treble with TREBLE/SLOW control (6) located on REPROD AMP board (CH I). |
| 8. Tiefenkorrektur mit Regler BASS/SLOW (7), Einschub REPROD AMP (CH I) im unteren Tonfrequenzbereich (< 100 Hz) vornehmen. | 8. Adjust lower frequency range (< 100 Hz) with BASS/SLOW control (7) located on REPROD AMP board (CH I). |

Anmerkung:

Bei Verwendung eines Messbandes bei dem der Frequenzgang mit Vollpegel aufgezeichnet ist, kann der Abgleich mittels des VU-Meters anstelle des externen Millivoltmeters vorgenommen werden.

Note:

When using a test tape whose frequency range has been recorded at full level, the frequency response can be adjusted with the VU meter instead of an external millivoltmeter.

- | | |
|--|---|
| 9. Frequenzgang-Abgleich für Kanal 2 (CH II) vornehmen, analog Positionen 1 bis 8. Die zugehörigen Schalter und Regler sind: SAFE-READY Schalter (68)
MONITOR Schalter (69)
Leitungsausgang (36)
Regler TREBLE/SLOW (26)
Regler BASS/SLOW (27) | 9. Adjust frequency response for channel 2 (CH II) analogous to steps 1 – 8. The associated switches and controls are:
SAFE-READY switch (68)
MONITOR switch (69)
Line output (36)
TREBLE/SLOW control (26)
BASS/SLOW control (27) |
|--|---|

5.6.10 Aufnahmeinstellungen

Anmerkung:

Überall wo die Anwendung von neuem Band vorgeschrieben ist, kann auch bespieltes Band verwendet werden. Die Aufzeichnung wird beim Aufnahmevorgang gelöscht.

Kontrolle der Oszillator-Frequenz, siehe Abschnitt 5.4.1.

5.6.10 Adjustments for record functions

Note:

Wherever the use of new tape is called for, prerecorded tape may also be used. However, the recording will be erased during the recording process.

For a check on oscillator frequency see chap. 5.4.1.

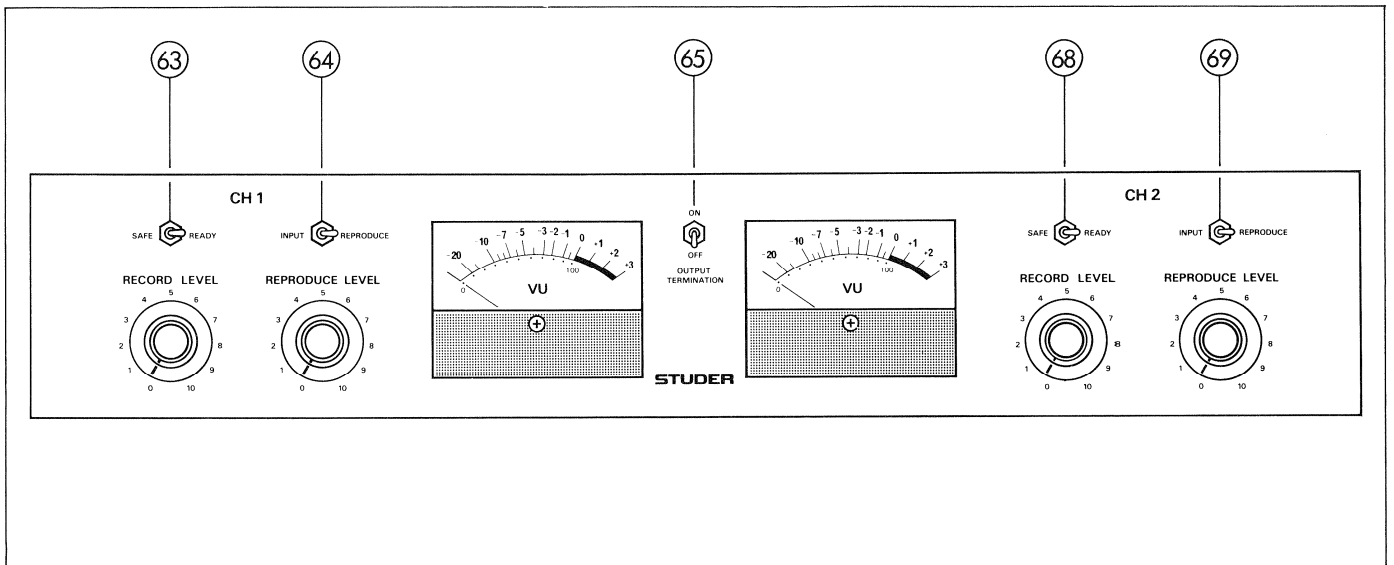

Fig. 5.30

5.6.11 Pegeleinstellen der Aufnahmeverstärker (FAST)

1. Gerät auf schnelle Bandgeschwindigkeit schalten.
2. SAFE-READY Schalter (63) auf SAFE.
3. MONITOR Schalter (64) auf REPRODUCE.
4. Schalter TERMINATION (65) auf ON.
5. Neuwertiges, leeres Band der gewünschten Bandsorte auflegen.
6. Tonfrequenz-Generator an Leitungseingang Kanal 1 (CH I) anschliessen.
Pegel: Bezugspegel
7. Gerät auf Aufnahme starten.

5.6.11 Adjustment of record amplifier levels (FAST)

1. Switch machine to fast tape speed.
2. Turn SAFE-READY switch (63) to SAFE.
3. Turn MONITOR switch (64) to REPRODUCE.
4. Turn TERMINATION switch (65) to ON.
5. Mount new, unrecorded tape of the desired quality.
6. Connect audio-frequency generator to line input channel 1 (CH I).
Level: reference level
7. Start machine in RECORD mode.

- | | |
|---|--|
| <p>8. Mit Regler LEVEL/FAST (8) am Einschub RECORD AMP (CH I) auf eine VU-Meter Anzeige von 0 VU abgleichen.</p> <p>9. Bei Zweikanalgeräten:
Pegeleinstellung für Kanal 2 (CH II) vornehmen, analog Positionen 1 bis 8.
Die zugehörigen Schalter, Anschlüsse und Regler sind:
SAFE-READY Schalter (68)
MONITOR Schalter (69)
Leitungs-Eingang (35)
Regler LEVEL/FAST (28)</p> | <p>8. Adjust LEVEL/FAST control (8) located on RECORD AMP board (CH I) to obtain a VU-meter reading of 0 VU.</p> <p>9. For two-channel machines:
Perform level adjustments for channel 2 (CH II) analogous to steps 1 – 8.
The associated switches, connections and controls are:
SAFE-READY switch (68)
MONITOR switch (69)
Line input (35)
LEVEL/FAST control (28)</p> |
|---|--|

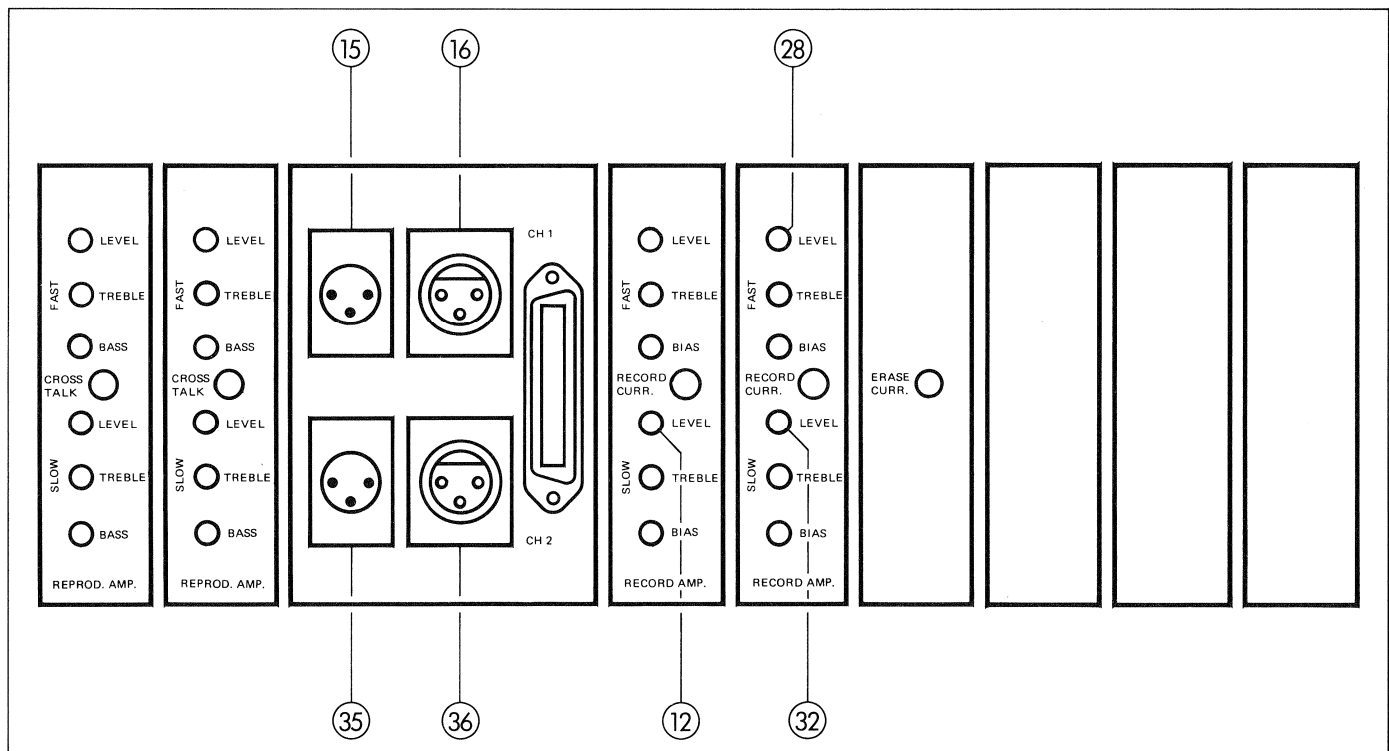

Fig. 5.38

5.6.12 Adjustment of record amplifier levels (SLOW)

1. Gerät auf langsame Bandgeschwindigkeit schalten.
2. SAFE-READY Schalter (63) auf READY.
3. MONITOR Schalter (64) auf REPRODUCE.
4. Schalter TERMINATION (65) auf ON.
5. Neuwertiges, leeres Band der gewünschten Bandsorte auflegen.
6. Tonfrequenz-Generator an Leitungs-Eingang Kanal 1 (15) (CH I) anschliessen.
Pegel: Bezugspegel

5.6.12 Pegeleinstellen der Aufnahmeverstärker (SLOW)

1. Switch machine to slow tape speed.
2. Turn SAFE-READY switch (63) to READY.
3. Turn MONITOR switch (64) to REPRODUCE.
4. Turn TERMINATION switch (65) to ON.
5. Mount new, unrecorded tape of the desired quality.
6. Connect audio-frequency generator to line input channel 1 (15) (CH I).
Level: reference level

- | | |
|--|---|
| <p>7. Gerät auf Aufnahme starten.</p> <p>8. Mit Regler LEVEL/SLOW (12) am Einschub RECORD AMP (CH I) auf eine VU-Meter Anzeige von 0 VU abgleichen.</p> <p>9. Bei Zweikanalgeräten:
Pegeleinstellung für Kanal 2 (CH II) vornehmen, analog Positionen 1 bis 8.
Die zugehörigen Schalter, Anschlüsse und Regler sind:
SAFE-READY Schalter (68)
MONITOR Schalter (69)
Leitungs-Eingang (35)
Regler LEVEL/SLOW (32)</p> | <p>7. Start machine in RECORD mode.</p> <p>8. Adjust LEVEL/SLOW control (12) located on RECORD AMP board (CH I) to obtain a VU-meter reading of 0 VU.</p> <p>9. For two-channel machines:
Perform level adjustments for channel 2 (CH II) analogous to steps 1 – 8.
The associated switches, connections and controls are:
SAFE-READY switch (68)
MONITOR switch (69)
Line input (35)
LEVEL/SLOW control (32)</p> |
|--|---|

5.6.13**Aufnahmekopf Spalteinstellung (AZIMUT)**

Nur für MONO-Geräte

1. Gerät auf schnelle Bandgeschwindigkeit schalten.
2. SAFE-READY Schalter (63) auf READY.
3. MONITOR Schalter (64) auf REPRODUCE.
4. Schalter TERMINATION (65) auf ON.

5.6.13**Record head azimuth adjustment**

For MONO machines only:

1. Switch machine to fast tape speed.
2. Turn SAFE-READY switch (63) to READY.
3. Turn MONITOR switch (64) to REPRODUCE.
4. Turn TERMINATION switch (65) to ON.

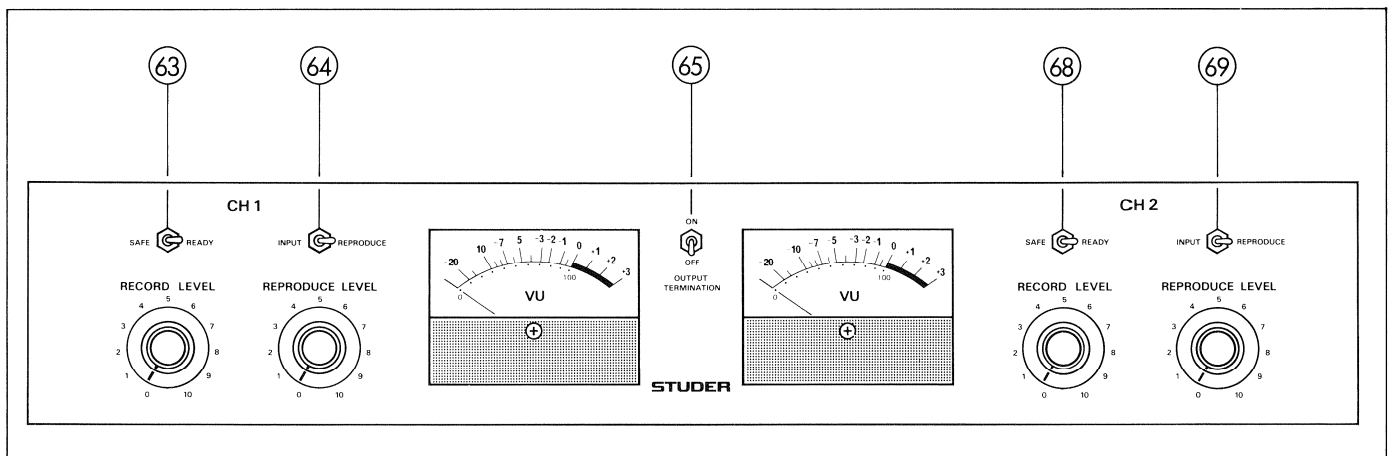

Fig. 5.30

- | | |
|--|--|
| <p>5. Tonfrequenz-Generator an den Leitungseingang (15) anschliessen.
Pegel: 20 dB unter Referenzpegel (CCIR)
10 dB unter Bezugspegel (NAB)
Frequenz: 10 kHz</p> <p>6. Tonfrequenz-Millivoltmeter an Leitungsausgang (16) (CH I) anschliessen.</p> <p>7. Neuwertiges, leeres Band der gewünschten Bandsorte auflegen und das Gerät auf Aufnahme starten.</p> | <p>5. Connect audio-frequency generator to line input (15).
Level: 20 dB below reference level (CCIR)
10 dB below reference level (NAB).
Frequency: 10 kHz.</p> <p>6. Connect audio-frequency millivoltmeter to line output (16) (CH I).</p> <p>7. Mount new, unrecorded tape of the desired quality and start in RECORD mode.</p> |
|--|--|

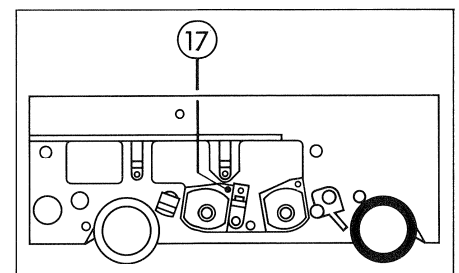

Fig. 5.16

8. Mit der Spaltjustierschraube (17) (siehe Fig. 5.16) den Aufnahmekopf auf Pegelmaximum justieren.
9. Falls eine starke Azimut-Korrektur erforderlich war, sind die Einstellungen gemäss Abschnitt 5.6.10 und 5.6.11 (Pegeleinstellung der Aufnahmeverstärker) zu wiederholen.
8. Adjust azimuth by turning adjustment screw (17) (see Fig. 5.16) to obtain maximum level.
9. If the azimuth adjustment was significant, the adjustments stated in chap. 5.6.10 and 5.6.11 (level adjustment of record amplifiers) must be repeated.

5.6.14

Aufnahmekopf Spalteinstellung (AZIMUT)

Für STEREO- oder 2-Spur-Geräte
Die folgende Phaseeinstellung kann mit einem 2-Kanal-Oszillographen (Abschnitt A) oder nach der Phasenmethode (Abschnitt B) durchgeführt werden. Die Wahl der Methode richtet sich nach den vorhandenen Messgeräten.

5.6.14

Record head azimuth adjustment

For STEREO or two-track machines:
The following phase adjustments can be performed with a 2-channel oscilloscope (Section A) or according to the phase method (Section B). The method to be chosen depends on the measuring instruments available.

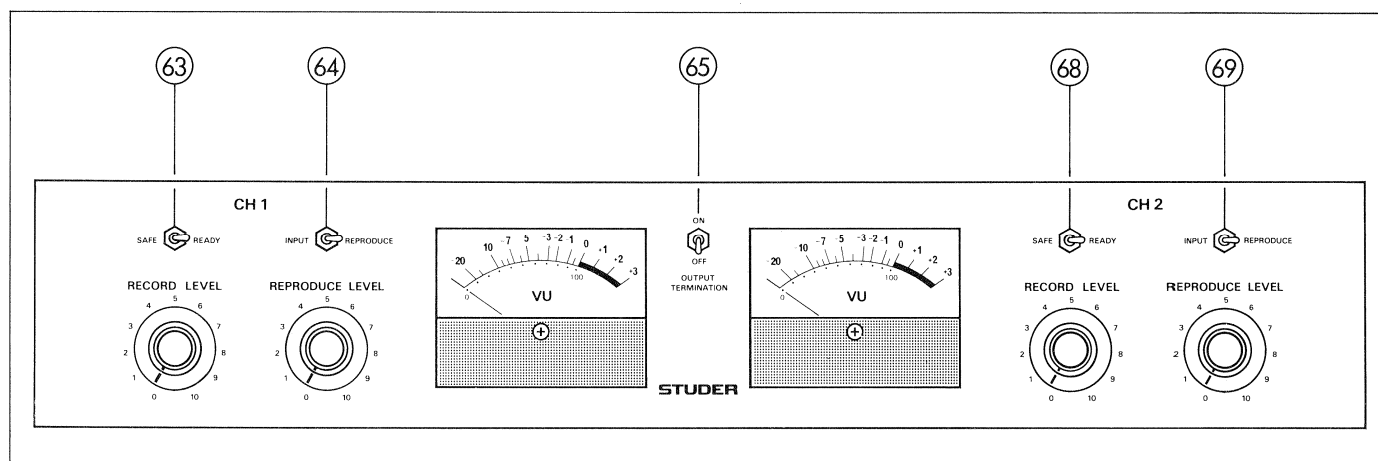

Fig. 5.30

1. SAFE-READY Schalter (63) und (68) auf READY.
2. MONITOR Schalter (64) und (69) auf REPRODUCE.
3. Schalter TERMINATION (65) auf ON.
1. Turn SAFE-READY switches (63) and (68) to READY.
2. Turn MONITOR switches (64) and (69) to REPRODUCE.
3. Turn TERMINATION switch (65) to ON.

A Messmethode mit 2-Kanal-Oszillographen

1. Gerät auf schnelle Bandgeschwindigkeit schalten.
2. Tonfrequenz-Generator parallel an die beiden Leitungs-Eingänge Kanal 1 (15) und Kanal 2 (35) (CH I + CH II) anschliessen.
Pegel: 20 dB unter Referenzpegel (CCIR)
10 dB unter Operating Level (NAB)
Frequenz: 1 ... 10 kHz
3. 2-Kanal-Oszillograph an Leitungs-Ausgänge Kanal 1 (16) und Kanal 2 (36) (CH I + CH II) anschliessen.

A Measuring method with 2-channel oscilloscope.

1. Switch machine to fast tape speed.
2. Connect audio-frequency generator in parallel to both line inputs channel 1 (15) and channel 2 (35) (CH I + CH II).
Level: 20 dB below reference level (CCIR)
10 dB below operating level (NAB).
Frequency: 1 ... 10 kHz.
3. Connect 2-channel oscilloscope to line output channel 1 (16) and channel 2 (36) (CH I + CH II).

4. Neuwertiges, leeres Band der gewünschten Bandsorte auflegen und das Gerät auf Aufnahme starten.
5. Die beiden Ausgangspegel des Gerätes auf identische Amplitude vorabgleichen (Regler TREBLE/FAST (9) / (29) an den Einschüben RECORD AMP).
6. Aufnahmekopf mittels Spaltjustierschraube (17) (Fig. 5.16) auf geringste Phasenwinkeldifferenz einstellen; bei schrittweiser Erhöhung der Frequenz, beginnend bei 1 kHz, bis 10 kHz. (Anzeigeverzögerung beachten, deshalb besonders langsam einstellen.)

4. Mount new, unrecorded tape of the desired quality and start the machine in RECORD mode.
5. Pre-adjust the output levels of the machine to identical amplitude (TREBLE/FAST control (9) / (20) on RECORD AMP boards.
6. Adjust azimuth of record head with adjustment screw (17) (Fig. 5.16) to obtain minimum phase angle difference. Starting at 1 kHz, continuously increase frequency to 10 kHz. (Observe display delay; therefore adjust slowly).

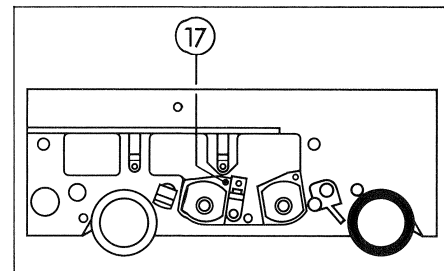

Fig. 5.16

B Phasenmethode

1. Gerät auf schnelle Bandgeschwindigkeit schalten.
2. Tonfrequenz-Generator an die beiden Leitungseingänge Kanal 1 (15) und Kanal 2 (35) (CH I + CH II) anschliessen. Pegel: 20 dB unter Referenzpegel (CCIR) 10 dB unter Operating Level (NAB) Frequenz: 10 kHz
3. Neuwertiges, leeres Band der gewünschten Bandsorte auflegen und das Gerät auf Aufnahme starten.
4. Die weiteren Mess- und Einstellvorgänge sind analog wie unter Abschnitt 5.6.6, Absatz B beschrieben auszuführen. Die zugehörigen Anschlüsse und Regler sind:
Leitungsausgänge 1 und 2 (16) und (36)
Regler TREBLE/FAST (9) / (20)
Spaltjustierschrauben (17)

B Phase method

1. Switch machine to fast tape speed.
2. Connect audio-frequency generator to both line inputs channel 1 (15) and channel 2 (35) (CH I + CH II). Level: 20 dB below reference level (CCIR) 10 dB below operating level (NAB) Frequency: 10 kHz
3. Mount new, unrecorded tape of the desired quality and start machine in PLAY mode.
4. The subsequent measuring and adjustment processes are analogous to those described in chap. 5.6.6, Section B. The associated connections and controls are:
Line outputs 1 and 2 (16) and (36)
TREBLE/FAST controls (9) / (29)
Azimuth adjustment screw (17)

5.6.15 Vormagnetisierung

Bei der Wahl der Vormagnetisierungs-Einstellung ist ein Kompromiss zu schliessen zwischen Verzerrungsgrad, Frequenzgang, Modulationsrauschen und Aussteuerungsgrad. Die Vormagnetisierungs-Einstellung wird weiter nicht allein durch die Bandsorte bestimmt, sondern ist stark abhängig von der Spaltbreite des Aufnahmekopfes.

Bei der Vormagnetisierungs-Einstellung wird der HF-Strom (bei konstantem NF-Signal) soweit über das Empfindlichkeitsmaximum des entsprechenden Bandes erhöht, bis die NF-Ausgangsspannung um einen bestimmten Betrag ΔE abgesunken ist.

Tabelle Fig. 5.20 Seite beachten.

5.6.15 Tape bias

When selecting the tape bias adjustment, a compromise has to be made between distortion level, frequency response, modulation noise, and modulation level. The tape bias setting is determined not only by the tape quality but is strongly dependent on the gap width of the record head.

When readjusting the bias setting, the HF current (with constant AF signal) is increased beyond the maximum sensitivity of the corresponding tape until the AF output voltage drops by a specific value ΔE .

See table fig. 5.20

Der Vormagnetisierungs-Abgleich erfolgt mit einer Modulationsfrequenz von 10 kHz. Um Übersteuerungen und Fehlmessungen zu vermeiden, ist der Eingangspegel auf -20 dB gegenüber Bezugspegel (Operating Level) zu reduzieren.

Balancing of the bias setting is performed with a modulation frequency of 10 kHz. To avoid overmodulation and erroneous readings, the input level is to be reduced to -20 dB as compared to the reference level (operating level).

Vormagnetisierung FAST

1. Gerät auf schnelle Bandgeschwindigkeit schalten.
2. SAFE-READY Schalter (63) auf READY.
3. MONITOR Schalter (64) auf REPRODUCE.
4. Schalter TERMINATION (65) auf ON.
5. Tonfrequenz-Millivoltmeter an Leitungsausgang Kanal 1 (16) (CH I) anschliessen.
6. Tonfrequenz-Generator an Leitungseingang Kanal 1 (15) (CH I) anschliessen.
Frequenz: 10 kHz
Pegel: 20 dB unter Bezugspegel
7. Neuwertiges, leeres Band auflegen und Gerät auf Aufnahme starten.

Bias setting FAST

1. Switch machine to fast tape speed.
2. Turn SAFE-READY switch (63) to READY.
3. Turn MONITOR switch (64) to REPRODUCE.
4. Turn TERMINATION (65) to ON.
5. Connect audio-frequency millivoltmeter to line output channel 1 (16) (CH I).
6. Connect audio-frequency generator to line input channel 1 (15) (CH I).
Frequency: 10 kHz
Level: 20 dB below reference level
7. Mount new, unrecorded tape and start machine in record mode.

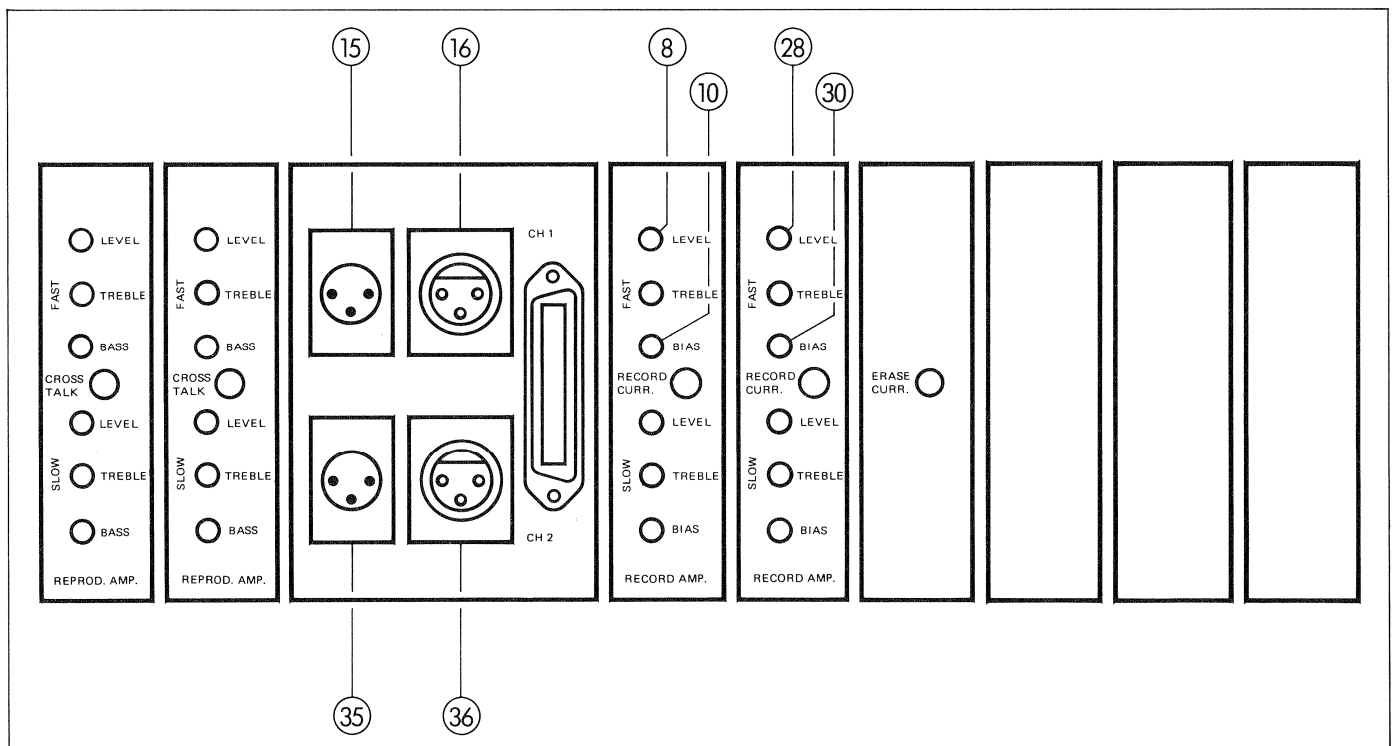

Fig. 5.39

8. Regler LEVEL/FAST (8), Einschub RECORD AMP (CH I), vorläufig so einstellen, dass sich am Tonfrequenz-Millivoltmeter eine Anzeige von 20 dB unter dem Bezugspegel einstellt.
8. Temporarily adjust LEVEL/FAST control (8), board RECORD AMP (CH I) to a setting where the audio-frequency millivoltmeter displays a value of 30 dB below the reference level.

- | | |
|---|--|
| <p>9. Regler BIAS/FAST (10), Einschub RECORD AMP (CH I), vom linken Anschlag in Uhrzeigerrichtung aufdrehen, bis die Maximal-Anzeige am Tonfrequenz-Millivoltmeter erreicht ist. (Empfindlichkeits-Maximum des Tonbandes.) Den Regler in Uhrzeigerrichtung weiterdrehen, bis die Anzeige am Tonfrequenz-Millivoltmeter um 3 bis 4 dB gesunken ist.</p> <p>10. Tonfrequenz-Generator auf 1 kHz einstellen und Pegel-Einstellung kontrollieren.</p> <p>11. Vormagnetisierungs-Abgleich für Kanal 2 (CH II) vornehmen, analog Positionen 1 bis 10.
Die zugehörigen Schalter, Anschlüsse und Regler sind:
SAFE-READY Schalter (68)
MONITOR Schalter (69)
Leitungs-Ausgang (36)
Leitungs-Eingang (35)
Regler LEVEL/FAST (28)
Regler BIAS/FAST (30)</p> | <p>9. Open BIAS/FAST control (10), board RECORD AMP (CH I) from the left limit position in a clockwise direction until the maximum reading at the audio-frequency millivoltmeter is obtained (sensitivity limit of the tape). Continue rotation in clockwise direction until the audio-frequency millivoltmeter shows a reading which has dropped by 3 to 4 dB.</p> <p>10. Adjust audio-frequency generator to 1 kHz. Check level and if necessary, adjust.</p> <p>11. Adjust bias setting for channel 2 (CH II) analogous to steps 1 to 10.
The associated switches, connections and controls are as follows:
SAFE-READY switch (68)
MONITOR switch (69)
Line output (36)
Line input (35)
LEVEL/FAST control (28)
BIAS/FAST control (30).</p> |
|---|--|

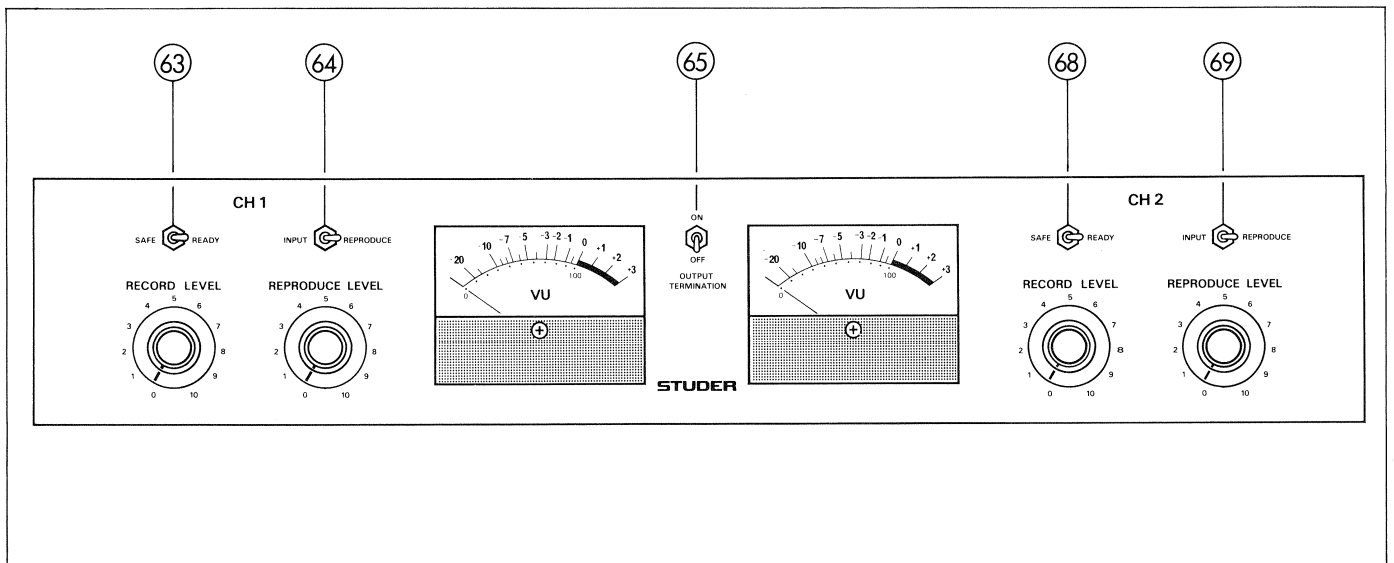

Fig. 5.30

Vormagnetisierung SLOW

1. Gerät auf schnelle Bandgeschwindigkeit schalten.
2. SAFE-READY Schalter (63) auf READY.
3. MONITOR Schalter (64) auf REPRODUCE.
4. Schalter TERMINATION (65) auf ON.
5. Tonfrequenz-Millivoltmeter an Leitungs-Ausgang Kanal 1 (16) (CH I) anschliessen.
6. Tonfrequenz-Generator an Leitungs-Eingang Kanal 1 (15) (CH I) anschliessen.
Frequenz: 10 kHz
Pegel: 20 dB unter Bezugspegel

Bias setting SLOW

1. Switch machine to slow tape speed.
2. Turn SAFE-READY switch (63) to READY.
3. Turn MONITOR switch (64) to REPRODUCE.
4. Turn TERMINATION (65) to ON.
5. Connect audio-frequency millivoltmeter to line output channel 1 (16) (CH I).
6. Connect audio-frequency generator to line input channel 1 (15) (CH I).
Frequency: 10 kHz
Level: 20 dB below reference level

- | | |
|--|---|
| <p>7. Neuwertiges, leeres Band auflegen und Gerät auf Aufnahme starten.</p> <p>8. Regler LEVEL/SLOW (12), Einschub RECORD AMP (CH I), vorläufig so einstellen, dass sich am Tonfrequenz-Millivoltmeter eine Anzeige von 20 dB unter dem Bezugspegel einstellt.</p> <p>9. Regler BIAS/SLOW (14), Einschub RECORD AMP (CH I), vom linken Anschlag in Uhrzeigerichtung aufdrehen, bis die Maximal-Anzeige am Tonfrequenz-Millivoltmeter erreicht ist. (Empfindlichkeits-Maximum des Tonbandes.) Den Regler in Uhrzeigerichtung weiterdrehen, bis die Anzeige am Tonfrequenz-Millivoltmeter um 5 bis 6 dB gesunken ist.</p> <p>10. Tonfrequenz-Generator auf 1 kHz einstellen und Pegel-Einstellung kontrollieren.</p> <p>11. Vormagnetisierungs-Abgleich für Kanal 2 (CH II) vornehmen, analog Positionen 1 bis 10.
Die zugehörigen Schalter, Anschlüsse und Regler sind:
SAFE-READY Schalter (68)
MONITOR Schalter (69)
Leitungs-Ausgang (36)
Leitungs-Eingang (35)
Regler LEVEL/SLOW (32)
Regler BIAS/SLOW (34)</p> | <p>7. Mount new, unrecorded tape and start machine in record mode.</p> <p>8. Temporarily adjust LEVEL/SLOW control (12), board RECORD AMP (CH I) to a setting where the audio-frequency millivoltmeter displays a value of 20 dB below the reference level.</p> <p>9. Open BIAS/SLOW control (14), board RECORD AMP (CH I) from the left limit position in a clockwise direction until the maximum reading at the audio-frequency millivoltmeter is obtained (sensitivity limit of the tape). Continue rotation in clockwise direction until the audio-frequency millivoltmeter shows a reading which has dropped by 5 to 6 dB.</p> <p>10. Adjust audio-frequency generator to 1 kHz. Check level and if necessary, adjust.</p> <p>11. Adjust bias setting for channel 2 (CH II) analogous to steps 1 to 10.
The associated switches, connections and controls are as follows:
SAFE-READY switch (68)
MONITOR switch (69)
Line output (36)
Line input (35)
LEVEL/SLOW control (32)
BIAS/SLOW control (34)</p> |
|--|---|

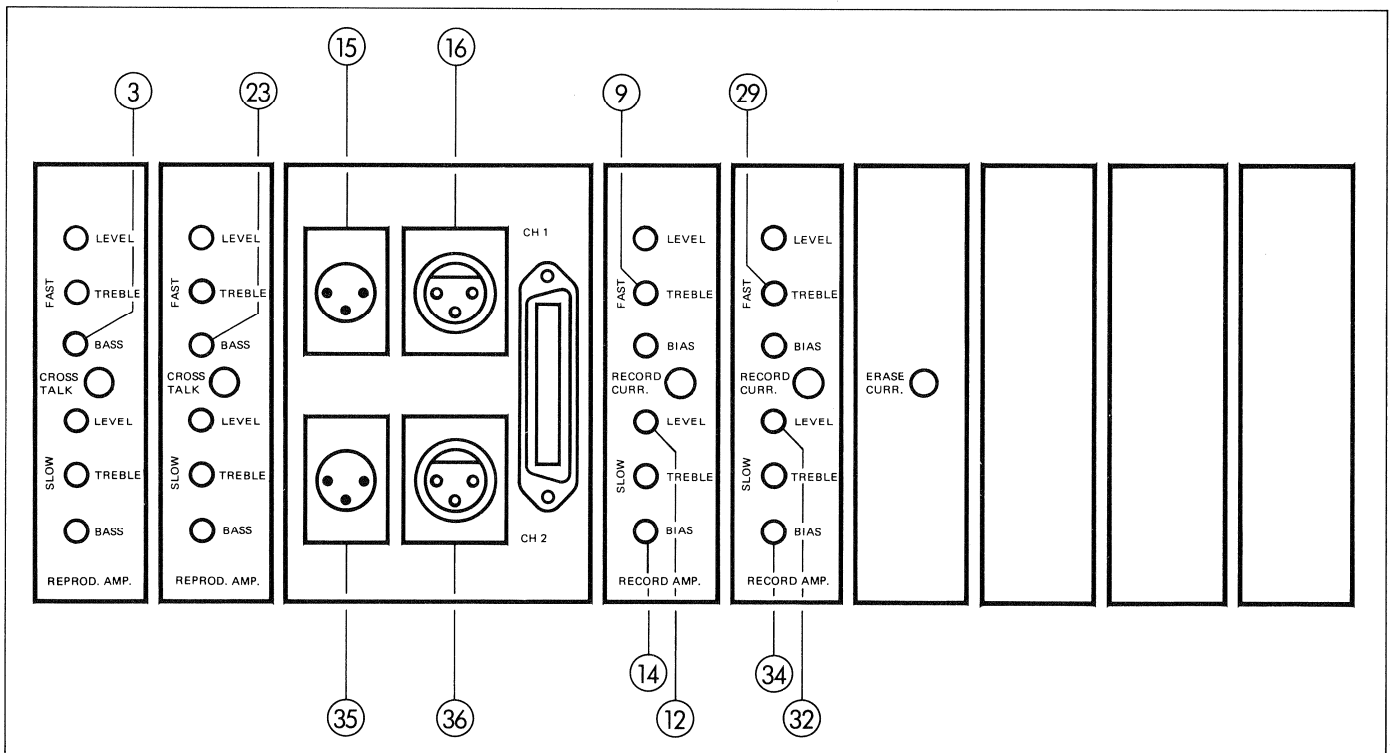

Fig. 5.40

5.6.16**Aufnahmefrequenzgang Abgleich (FAST)**

1. Gerät auf schnelle Bandgeschwindigkeit schalten.
2. SAFE-READY Schalter (63) auf READY.
3. MONITOR Schalter (64) auf REPRODUCE.
4. Schalter TERMINATION (65) auf ON.
5. Neuwertiges, leeres Band der gewünschten Bandsorte auflegen.
6. Tonfrequenz-Generator an Leitungseingang Kanal 1 (15) (CH I) anschliessen.
Frequenz: 15 kHz
Pegel: Bezugspegel
7. Gerät auf Aufnahme starten.
8. Höhenkorrektur mit Regler TREBLE/FAST (9), Einschub RECORD AMP (CH I), vornehmen.
9. Tonfrequenz-Generator im unteren Frequenzbereich (30 ... 100 Hz variieren).
10. Tiefenkorrektur mit Regler BASS/FAST (3), Einschub REPROD AMP (CH I), vornehmen. Auf linearen Ausgangspegel einstellen.
11. Frequenzgang-Abgleich für Kanal 2 (CH II) vornehmen, analog Positionen 1 bis 10. Die zugehörigen Schalter, Anschlüsse und Regler sind:
SAFE-READY Schalter (68)
MONITOR Schalter (69)
Leitungseingang (35)
Regler TREBLE/FAST (29)
Regler BASS/FAST (23)

5.6.17**Aufnahmefrequenzgang Abgleich (SLOW)**

1. Gerät auf langsame Bandgeschwindigkeit schalten.
2. SAFE-READY Schalter (63) auf READY stellen.
3. MONITOR Schalter (64) auf REPRODUCE.
4. Schalter TERMINATION (65) auf ON.
5. Neuwertiges, leeres Band der gewünschten Bandsorte auflegen.

5.6.16**Adjustment of record frequency response (FAST)**

1. Switch machine to fast tape speed.
2. Turn SAFE-READY switch (63) to READY.
3. Turn MONITOR switch (64) to REPRODUCE.
4. Turn TERMINATION (65) to ON.
5. Mount new, unrecorded tape of desired tape quality.
6. Connect audio-frequency generator to line input channel 1 (15) (CH I).
Frequency: 15 kHz.
Level: reference level.
7. Start machine in RECORD mode.
8. Adjust treble with TREBLE/FAST control (9) located on RECORD AMP board (CH I)
9. Vary output of audio-frequency generator in lower frequency range (30 ... 100 Hz).
10. Adjust bass with BASS/FAST control (3) located on REPROD AMP board (CH I). Adjust for linear output level.
11. Balance frequency response for channel 2 (CH II) analogous to steps 1 to 10. The associated switches, connections and controls are:
SAFE-READY switch (68)
MONITOR switch (69)
Line input (35)
TREBLE/FAST control (29)
BASS/FAST control (23).

5.6.17**Adjustment of record frequency response (SLOW)**

1. Switch machine to slow tape speed.
2. Turn SAFE-READY switch (63) to READY.
3. Turn MONITOR switch (64) to REPRODUCE.
4. Turn TERMINATION (65) to ON.
5. Mount new, unrecorded tape of desired tape quality.

- | | |
|--|--|
| <p>6. Tonfrequenz-Generator an Leitungseingang Kanal 1 (15) (CH I) anschliessen.
Frequenz: 12 kHz
Pegel: Bezugspegel</p> <p>7. Gerät auf Aufnahme starten.</p> <p>8. Höhenkorrektur mit Regler TREBLE/SLOW (13), Einschub RECORD AMP (CH I), vornehmen.</p> <p>9. Tonfrequenz-Generator im unteren Frequenzbereich (30 ... 100 Hz) variieren.</p> <p>10. Tiefenkorrektur mit Regler BASS/SLOW (7), Einschub REPROD AMP (CH I), vornehmen. Auf linearen Ausgangspegel einstellen.</p> <p>11. Frequenzgang-Abgleich für Kanal 2 (CH II) vornehmen, analog Positionen 1 bis 10. Die zugehörigen Schalter, Anschlüsse und Regler sind:
SAFE-READY Schalter (68)
MONITOR Schalter (69)
Leitungseingang (35)
Regler TREBLE/SLOW (33)
Regler BASS/SLOW (27)</p> | <p>6. Connect audio-frequency generator to line input channel 1 (15) (CH I).
Frequency: 12 kHz
Level: reference level</p> <p>7. Start machine in RECORD mode.</p> <p>8. Adjust treble with TREBLE/SLOW control (13) located on RECORD AMP board (CH I).</p> <p>9. Vary output of audio-frequency generator in lower frequency range (30 ... 100 Hz).</p> <p>10. Adjust bass with BASS/SLOW control (7) located on REPROD AMP board (CH I). Adjust for linear output level.</p> <p>11. Adjust frequency response for channel 2 (CH II) analogous to steps 1 – 10. The associated switches, connections and controls are:
SAFE-READY switch (68)
MONITOR switch (69)
Line input (35)
TREBLE/SLOW control (33)
BASS/SLOW control (27)</p> |
|--|--|

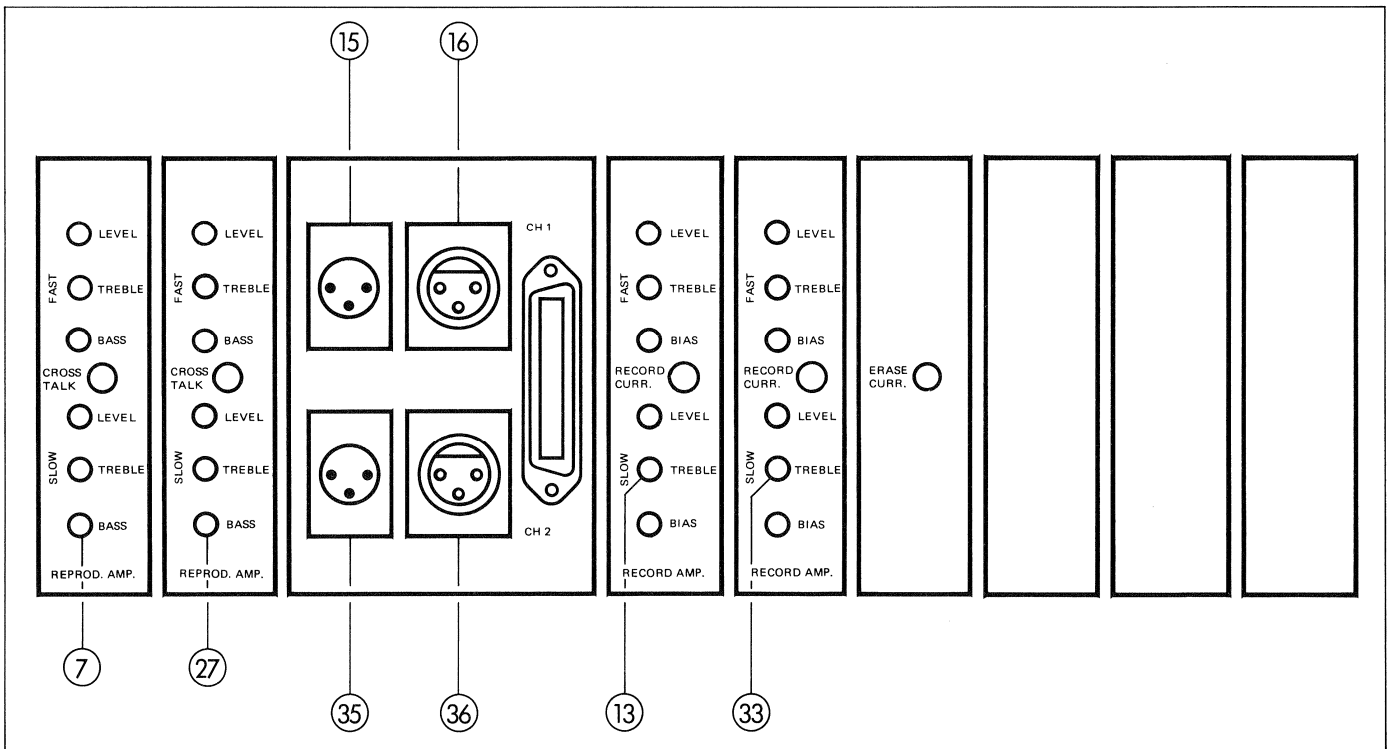

Fig. 5.41

5.6.18**Frequenzgang "über Band" kontrollieren
(FAST)**

1. Gerät auf schnelle Bandgeschwindigkeit schalten.
2. SAFE-READY Schalter (63) auf READY.
3. MONITOR Schalter (64) auf REPRODUCE.
4. Tonfrequenz-Generator an Leitungs-Eingang Kanal 1 (15) (CH I) anschliessen.
Pegel: Operating Level (NAB)
20 dB unter Bezugspegel (CCIR)
5. Bei CCIR-Entzerrung Tonfrequenz-Millivoltmeter am Leitungs-Ausgang Kanal 1 (16) anschliessen.
6. Neuwertiges, leeres Band der gewünschten Bandsorte auflegen und Gerät auf Aufnahme starten.
7. Tonfrequenz-Generator innerhalb des gesamten Tonspektrums durchstimmen. Die positiven und die negativen Abweichungen kontrollieren.
8. Frequenzgang-Kontrolle für Kanal 2 (CH II) vornehmen, analog Positionen 1 bis 7.
Die zugehörigen Schalter und Anschlüsse sind:
SAFE-READY Schalter (68)
MONITOR Schalter (69)
Leitungs-Eingang (35)
Leitungs-Ausgang (36)

5.6.18**Checking of frequency response "over all"
(FAST)**

1. Switch machine to fast tape speed.
2. Turn SAFE-READY switch (63) to READY.
3. Turn MONITOR switch (64) to REPRODUCE.
4. Connect audio-frequency generator to line input channel 1 (15) (CH I).
Level: operating level (NAB)
20 dB below reference level (CCIR)
5. For CCIR equalization connect audio-frequency millivoltmeter to line output channel 1 (16).
6. Mount new, unrecorded tape of the desired quality and start machine in RECORD mode.
7. Tune audio-frequency generator throughout the entire sound spectrum. Check positive and negative aberrations.
8. Check frequency response for channel 2 (CH II) analogous to steps 1 – 7.
The associated switches and connections are:
SAFE-READY switch (68)
MONITOR switch (69)
Line input (35)
Line output (36)

5.6.19**Checking of frequency response "over all"
(SLOW)**

1. Gerät auf langsame Bandgeschwindigkeit schalten.
2. SAFE-READY Schalter (63) auf READY
3. MONITOR Schalter (64) auf REPRODUCE.
4. Tonfrequenz-Millivoltmeter an Leitungs-Ausgang Kanal 1 (16) (CH I) anschliessen.
5. Tonfrequenz-Generator an Leitungs-Eingang Kanal 1 (15) (CH I) anschliessen.
Pegel: 10 dB unter Operating Level (NAB)
20 dB unter Bezugspegel (CCIR)
6. Neuwertiges, leeres Band der gewünschten Bandsorte auflegen.

5.6.19**Frequenzgang "über Band" kontrollieren
(SLOW)**

1. Switch machine to slow tape speed.
2. Turn SAFE-READY switch (63) to READY.
3. Turn MONITOR switch (64) to REPRODUCE.
4. Connect audio-frequency generator to line input channel 1 (16) (CH I).
5. For CCIR equalization connect audio-frequency millivoltmeter to line output channel 1 (15) (CH I).
Level: 10 dB below operating level (NAB)
20 dB below reference level (CCIR)
6. Mount new, unrecorded tape of the desired quality.

- | | |
|---|---|
| <p>7. Gerät auf Aufnahme starten.</p> <p>8. Tonfrequenz-Generator innerhalb des gesamten Tonspektrums durchstimmen, die positiven und die negativen Abweichungen kontrollieren.</p> <p>9. Frequenzgang-Kontrolle für Kanal 2 (CH II) vornehmen, analog Positionen 1 bis 8.
Die zugehörigen Schalter und Anschlüsse sind:
SAFE-READY Schalter (68)
MONITOR switch (69)
Leitungs-Ausgang (36)
Leitungs-Eingang (35)</p> | <p>7. Start machine in RECORD mode.</p> <p>8. Tune audio-frequency generator throughout the entire sound spectrum. Check positive and negative aberrations.</p> <p>9. Check frequency response for channel 2 (CH II) analogous to steps 1 – 8.
The associated switches and connections are:
SAFE-READY switch (68)
MONITOR switch (69)
Line input (35)
Line output (36)</p> |
|---|---|

Anmerkung:

- Liegt der Frequenzgang nicht innerhalb der garantierten Daten, so sind zunächst die folgenden Punkte zu überprüfen.
- Tonköpfe verschmutzt oder magnetisiert.
 - Spalteinstellung des Aufnahmepkopfes nicht korrekt.
 - Aufnahmepegel für die verwendete Bandsorte zu hoch; das Band arbeitet bei hohen Frequenzen im Sättigungsbereich.
 - Vormagnetisierungs-Einstellung nicht korrekt durchgeführt oder falsche Einstellung für die gewählte Bandsorte.
 - Höhereinstellung (TREBLE) nicht korrekt.

Note:

- If the frequency response does not fall within the guaranteed data, the following items should be rechecked:
- Head dirty or magnetized
 - Azimuth setting of record head incorrect.
 - Recording level is too high for the type of tape used. With high frequencies, the tape approaches saturation level.
 - Bias setting incorrectly adjusted or wrong setting does not match type of tape.
 - Treble control set incorrectly.

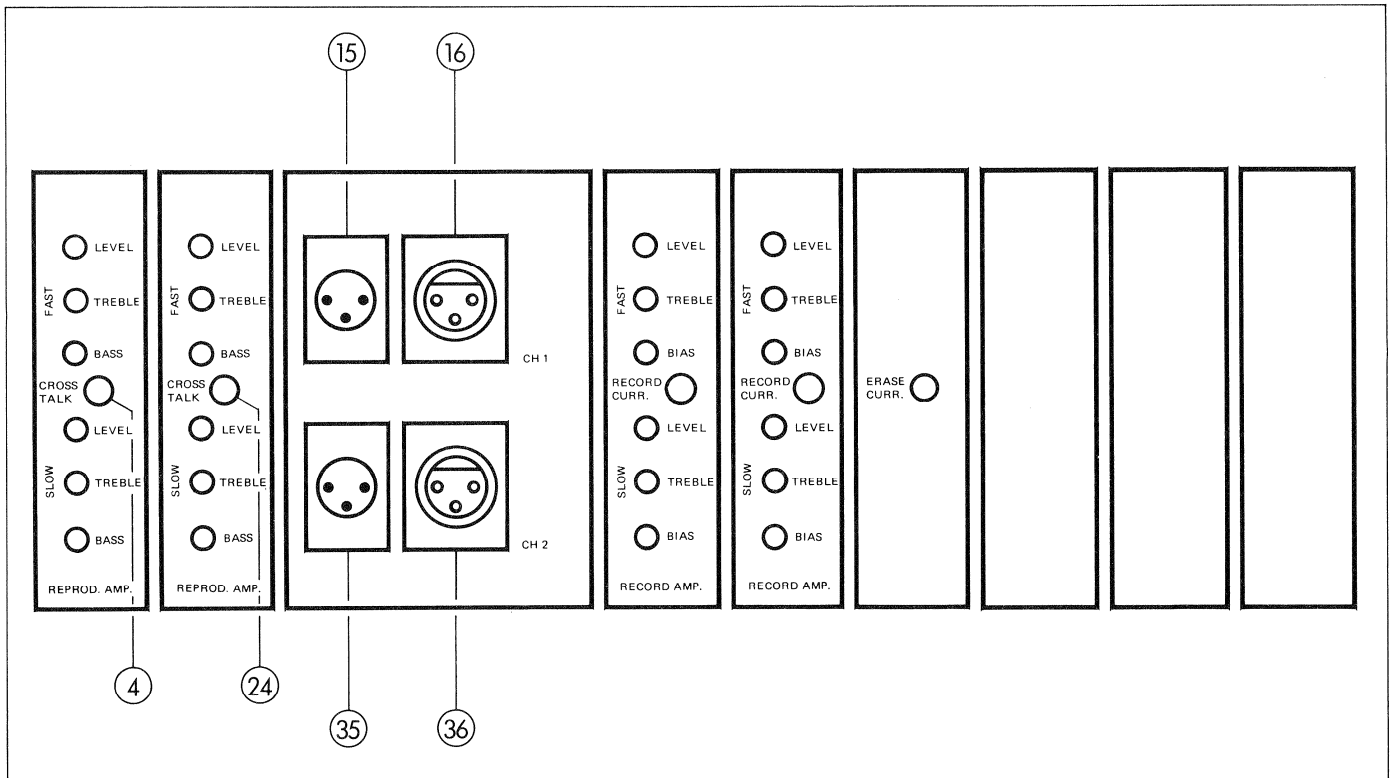

Fig. 5.42

5.6.20**Einstellen der Übersprechkompensation**

Die nachfolgenden Einstellungen müssen mit einem selektiven Messgerät durchgeführt werden.

1. Gerät auf schnelle Bandgeschwindigkeit schalten.
2. SAFE-READY Schalter (63) / (68) auf READY.
3. MONITOR Schalter (CH II) (64) / (69) auf REPRODUCE.
4. Schalter TERMINATION (65) auf ON.
5. Tonfrequenz-Generator an Leitungs-Eingang Kanal 1 (15) (CH I) anschliessen.
Pegel: Bezugspegel (operating level)
Frequenz: 3 kHz
6. Frequenz-Analysator an Leitungs-Ausgang Kanal 2 (36) (CH II) anschliessen.
7. Neuwertiges, leeres Band der gewünschten Bandsorte auflegen und auf Aufnahme starten.
8. Übersprech-Kompensation von Kanal 1 zu Kanal 2: Mit Regler CROSSTALK (4), Einschub REPROD AMP (CH I), Übersprechen auf Minimum Anzeige am Frequenz-Analysator einstellen.
9. Tonfrequenz-Generator an Leitungs-Eingang Kanal 2 (35) (CH II) anschliessen.
Gleiche Pegel und gleiche Frequenz.
10. Frequenz-Analysator an Leitungs-Ausgang Kanal 1 (16) (CH I) anschliessen.
11. Band auf Aufnahme starten.
12. Übersprech-Kompensation von Kanal 2 zu Kanal 1: Mit Regler CROSSTALK (24), Einschub REPROD AMP (CH II), Übersprechen auf Minimum-Anzeige am Frequenz-Analysator einstellen.

5.6.20**Adjustment of crosstalk compensation**

The following settings must be performed with a selective measuring instrument.

1. Switch machine to fast tape speed.
2. Turn SAFE-READY switches (63)/(68) to READY.
3. Turn MONITOR switches (CH II) (64)/(69) to REPRODUCE.
4. Turn TERMINATION (65) to ON.
5. Connect audio-frequency generator to line input channel 1 (15) (CH I).
Level: reference (operating) level
Frequency: 3 kHz
6. Connect harmonic analyzer to line output channel 2 (36) (CH II).
7. Mount new, unrecorded tape of desired quality and start machine in RECORD mode.
8. Crosstalk compensation between channel 1 and 2: Adjust CROSSTALK control (4) located on REPROD AMP (CH I) board to obtain minimum reading at harmonic analyzer.
9. Connect audio-frequency generator to line input of channel 2 (35) (CH II).
Same levels and frequency.
10. Connect harmonic analyzer to line output of channel 1 (16) (CH I).
11. Start machine in RECORD mode.
12. Crosstalk compensation between channel 2 and channel 1: Adjust CROSSTALK control (24) located on REPROD AMP (CH II) board to obtain minimum reading on harmonic analyzer.

CONTENTS

DESCRIPTION	SCHEMATIC NO.		SECTION/PAGE
GENERAL			6
STUDER ELECTRONIC CARDS			6/3
PRESENTATION OF GROUPS			6/5
REMOTE MODE CONTROL		GR 22 EL 22	6/6
CUTTER CONTROL ASSEMBLY		GR 19 EL 21	6/7
POWER SUPPLY UNIT	1.080.320/322	GR 1/2	6/8
STABILIZER (TAPE TRANSPORT)	1.080.370-81	GR 20 EL 2	6/11
STABILIZER 2 CHANNEL (AUDIO)	1.080.988		6/15
STABILIZER 4 CHANNEL (AUDIO) A80 RTQ	1.080.964-81		6/17
COMMAND SWITCH BOARD	1.080.275	GR 17	6/19
SPEED CONVERTER BOARD	1.080.979-81		6/21
BASIS BOARD/COUNTER	1.228.812	GR 18	6/23
COUNTER DECODER	1.228.811	GR 18	6/27
COUNTER	1.228.813	GR 18	6/31
DISPLAY	1.228.814	GR 18	6/31
TAPE TRANSPORT CONTROL			7
TAPE TRANSPORT CONTROL/BLOCK DIAGM A80 R			7/3
PRESSURE ROLLER ASSEMBLY	1.080.124	GR 15 EL 1	7/4
TAPE TENSION CONTROL ASSEMBLY L/R	1.080.142/146	GR 11/12 EL 1	7/5
OPTICAL TAPE END SENSOR		GR 30 EL 1	7/6
TAPE MOVE AND DIRECTION SENSOR UNIT	1.080.181	GR 14 EL 1/2	7/7
CONTACTOR	1.080.381	GR 20 EL 4	7/11
SPOOLING MOTOR CONTROL 1/4" + 1/2" (7,5 - 15 ips)	1.080.383	GR 20 EL 5	7/15
SPOOLING MOTOR CONTROL 1/4" + 1/2" (15 - 30 ips)	1.080.385-81	GR 20 EL 5	7/19
CAPSTAN SERVO WITH VARIABLE SPEED CONTROL	1.080.372/374/377	GR 20 EL 6	7/23
IC DECODER AND DRIVERS	1.080.391	GR 20 EL 8	7/27
IC MEMORY AND COUNTER	1.080.393	GR 20 EL 9	7/31
ATTENUATOR AND PREAMPLIFIER	1.080.396	GR 20 EL 10	7/35
ZERO LOCATOR	1.080.395	GR 20 EL 11	7/39
AUDIO			8
AUDIO BLOCK DIAGRAM WITH STANDARD CONNECTOR PANEL			8/3
AUDIO BLOCK DIAGRAM WITH MONO/STEREO CONNECTOR PANEL			8/4
AUDIO BLOCK DIAGRAM WITH VU-METER PANEL			8/5
AUDIO BASIS BOARD / 2 CHANNEL	1.080.980		8/7
AUDIO BASIS BOARD / 4 CHANNEL A80 RTQ	1.080.962		8/8
WIRING DIAGRAMS HEADBLOCK ASSEMBLIES			8/9
REPRODUCE AMPLIFIER	1.080.986		8/11
RECORD AMPLIFIER	1.080.982		8/15
OSCILLATOR STEREO	1.080.984		8/19
OSCILLATOR 2 TRACK	1.080.987		8/23
OSCILLATOR 4 CHANNEL A80 RTQ	1.080.965		8/27
PILOT TONE AMPLIFIER MK II	1.080.932		8/29
CONNECTION PANEL (STANDARD) USA/EURO	1.080.989/997		8/33
CONNECTION PANEL (MONO/STEREO) USA/EURO	1.080.994/998		8/37
CONNECTION PANEL (VU-METER PANEL) USA/EURO	1.080.993/991		8/41
VU-METER PANEL	1.080.950		8/43
EARLIER SCHEMATICS			9

STUDER ELECTRONIC CARDS

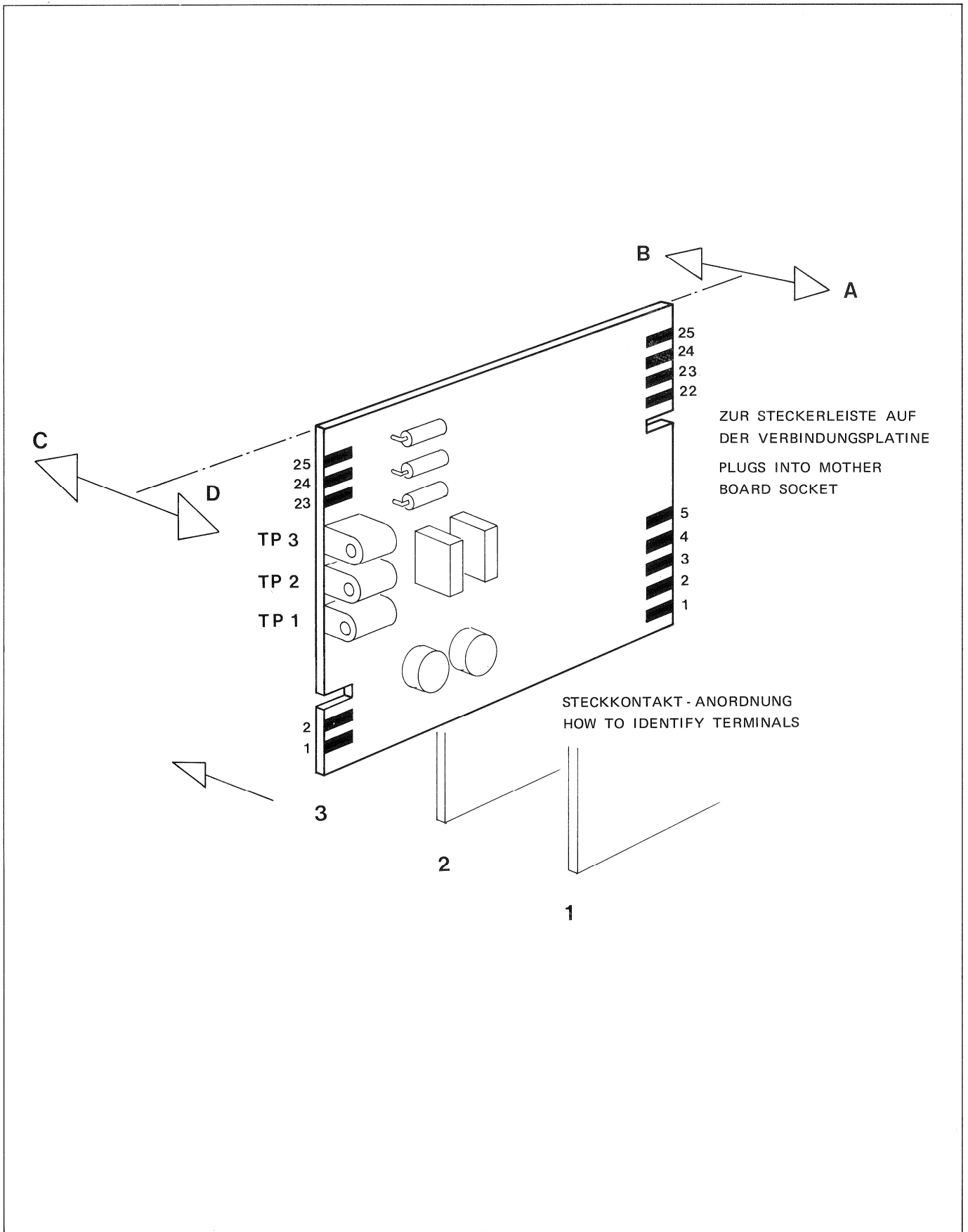

PRESENTATION OF GROUPS

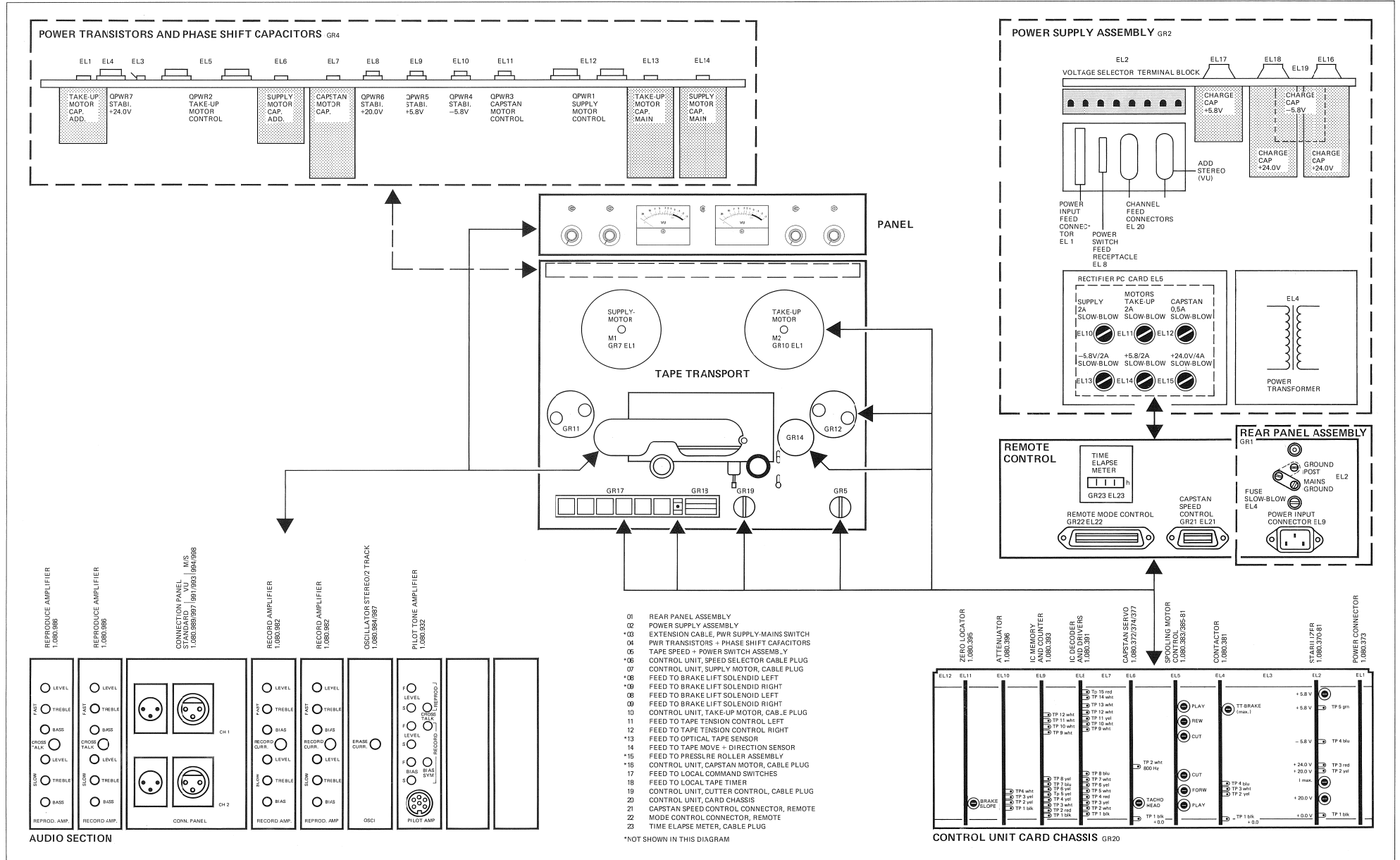

REMOTE MODE CONTROL GR 22 EL 22

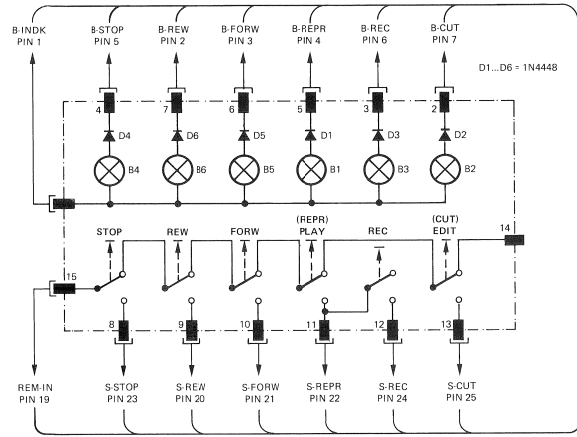

REMOTE CONTROL / TAPE TRANSPORT
FERNSTEUERUNG / LAUFWERK

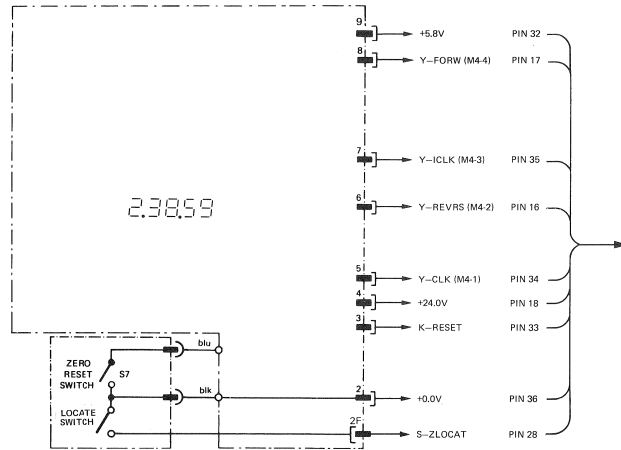

REMOTE CONTROL / TAPE TIMER ASSEMBLY 1.228.830
FERNSTEUERUNG / BANDZÄHLER-EINHEIT

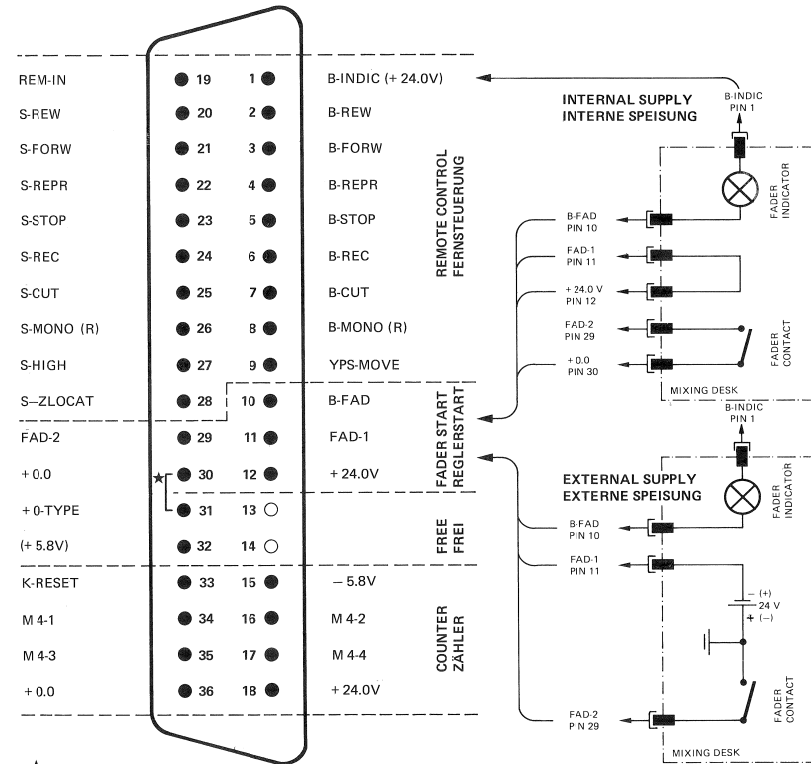

* INTERCONNECTION
IN 15/30 ips MACHINES
VERBINDUNG IN
15/30" -GERÄTEN

GR 22 EL 22
REMOTE MODE CONTROL CONNECTOR
FERNSTEUERUNGS - ANSCHLUSS

FADER START CIRCUITS
REGLER START-SCHALTKREISE

CUTTER CONTROL ASSEMBLY GR19 EL1

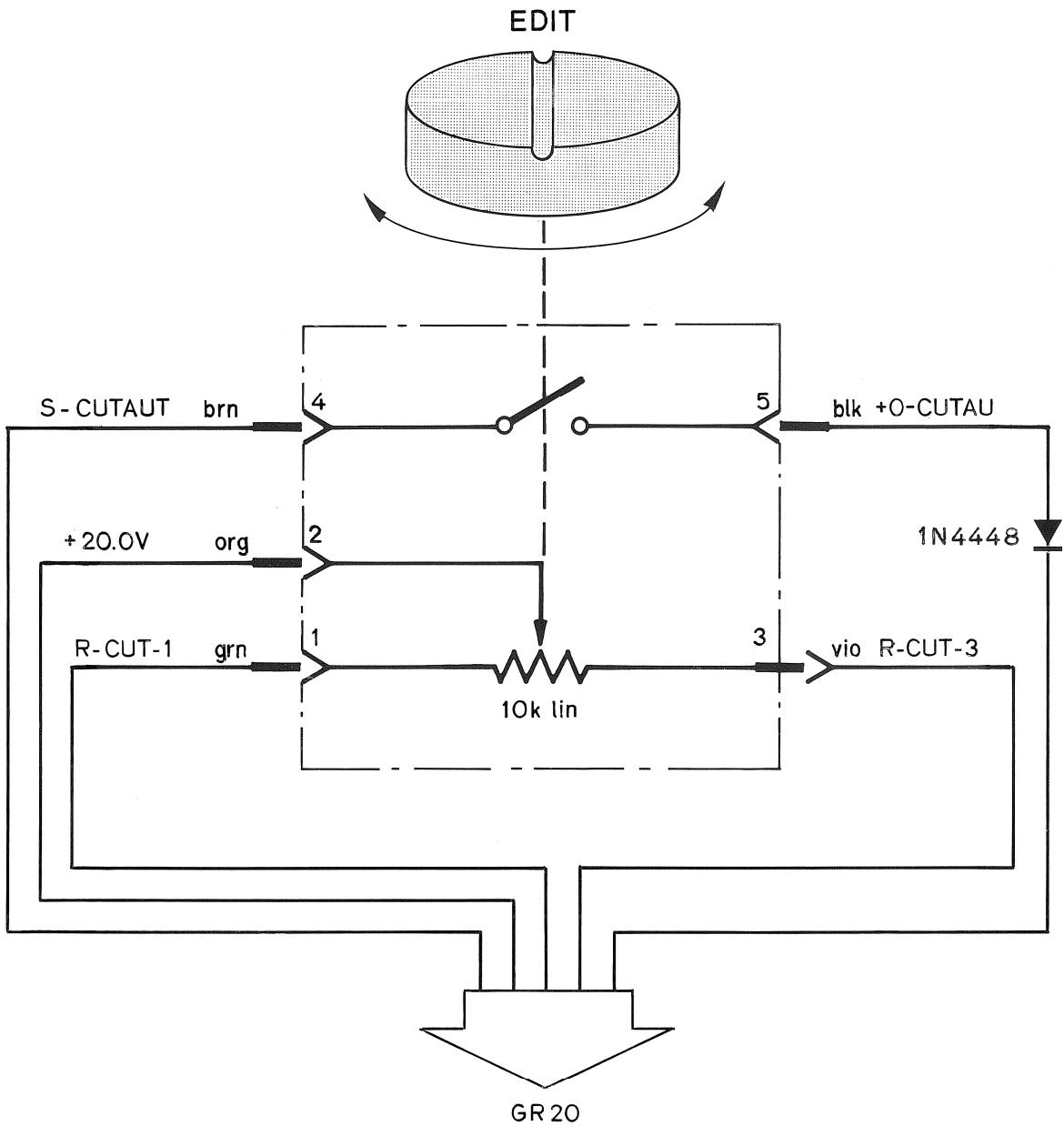

POWER SUPPLY UNIT 1.080.320/322 GR1/2

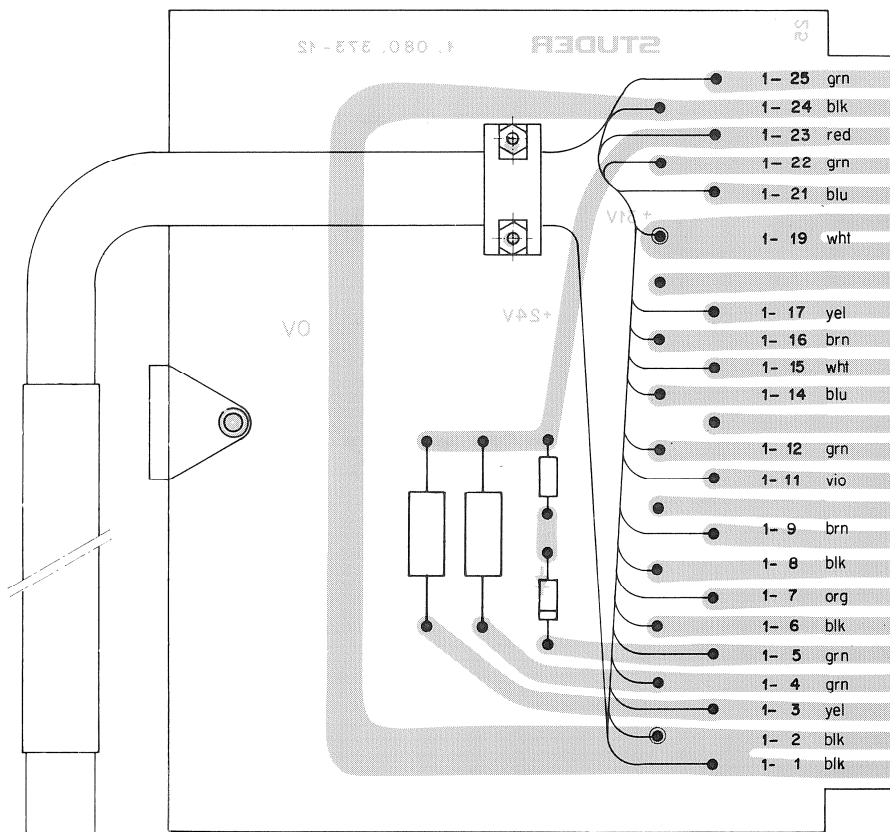
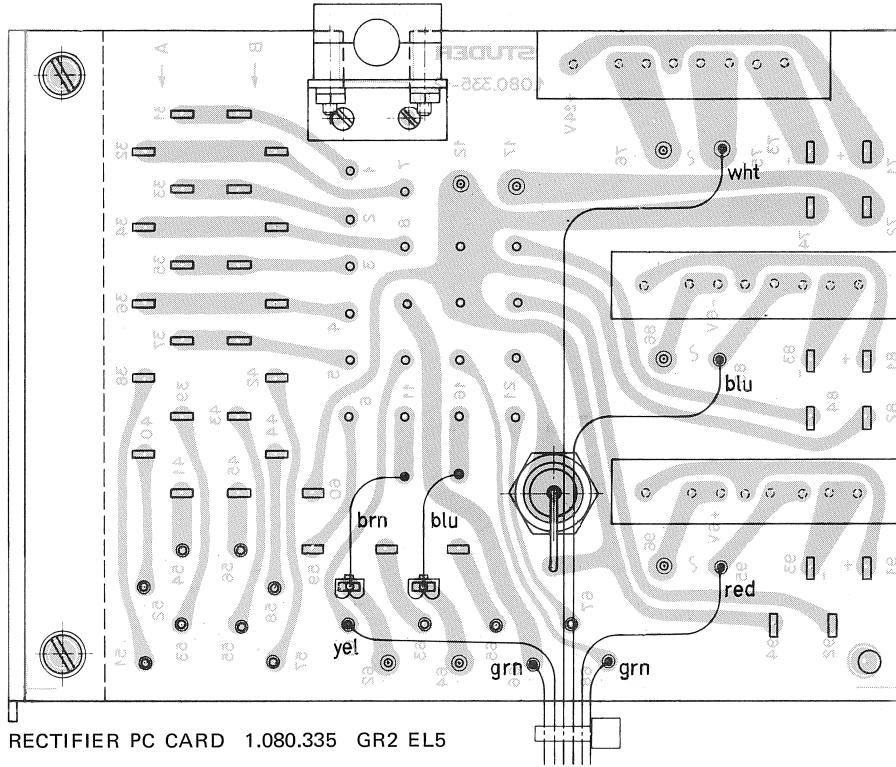

POWER SUPPLY UNIT 1.080.320/322 GR1/2

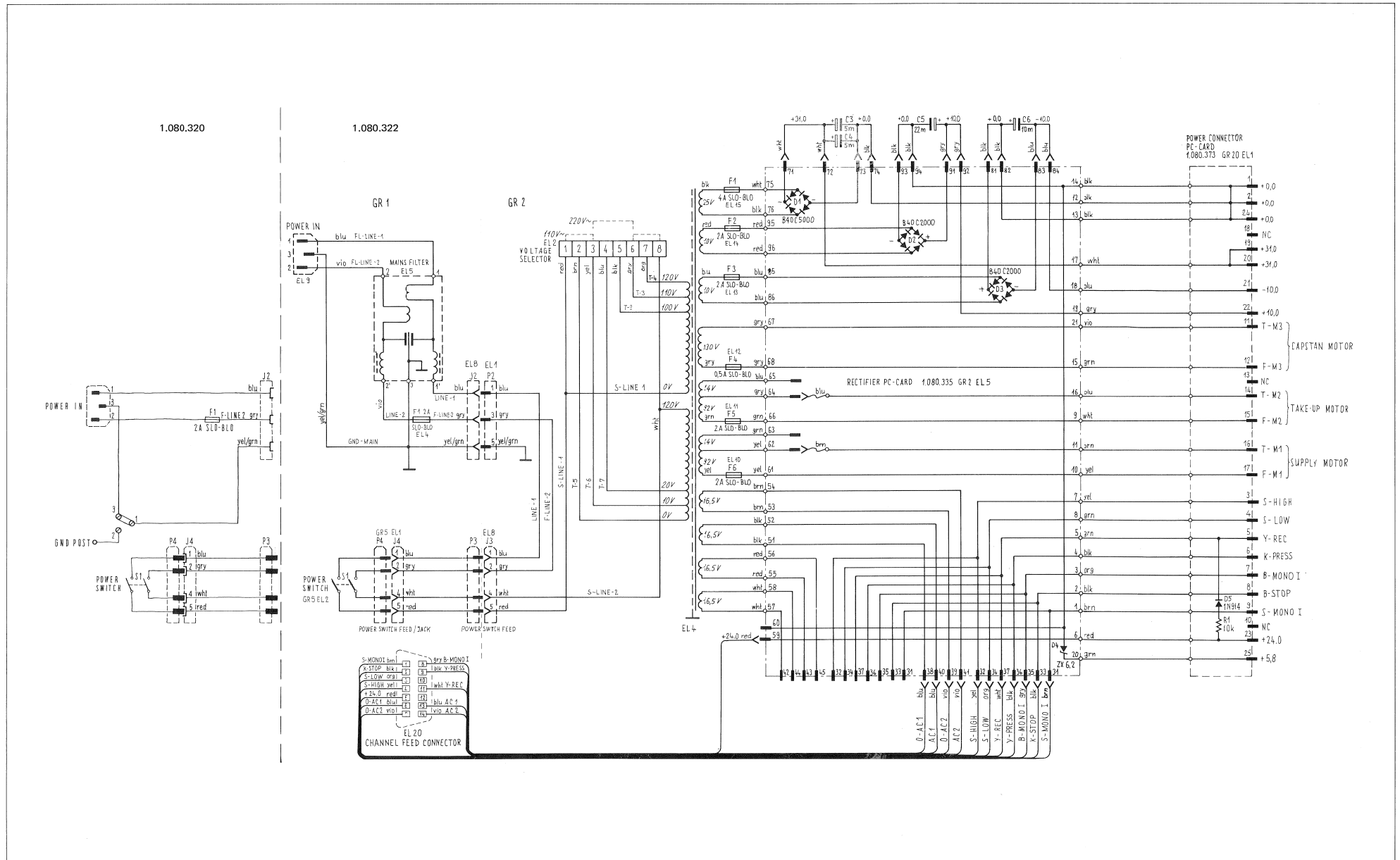

STABILIZER (TAPE TRANSPORT) 1.080.370-81 GR20 EL2

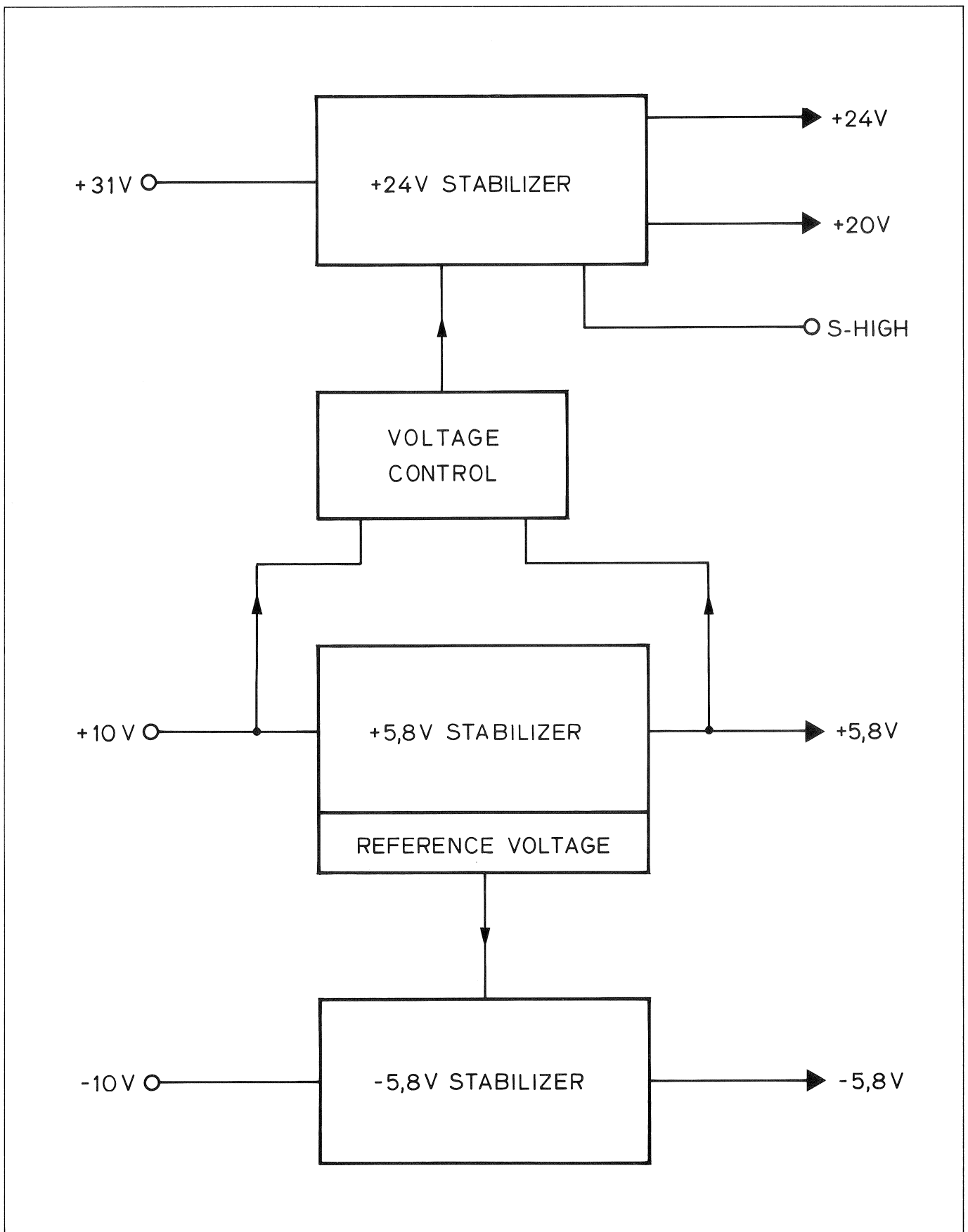

STABILIZER (TAPE TRANSPORT) 1.080.370-81 GR 20 EL 2

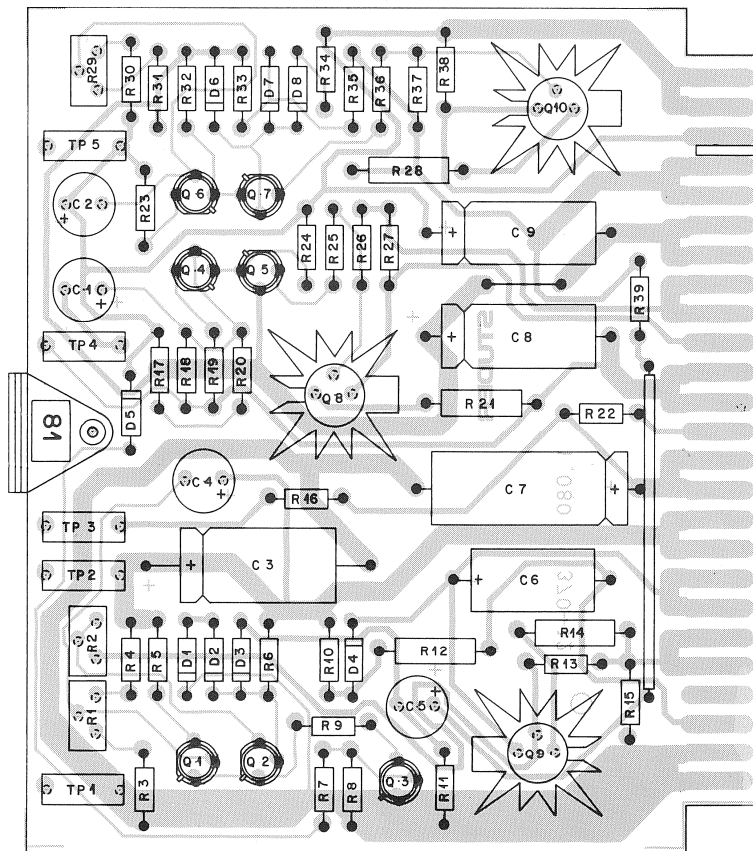

STABILIZER (TAPE TRANSPORT) 1.080.370-81 GR 20 EL 2

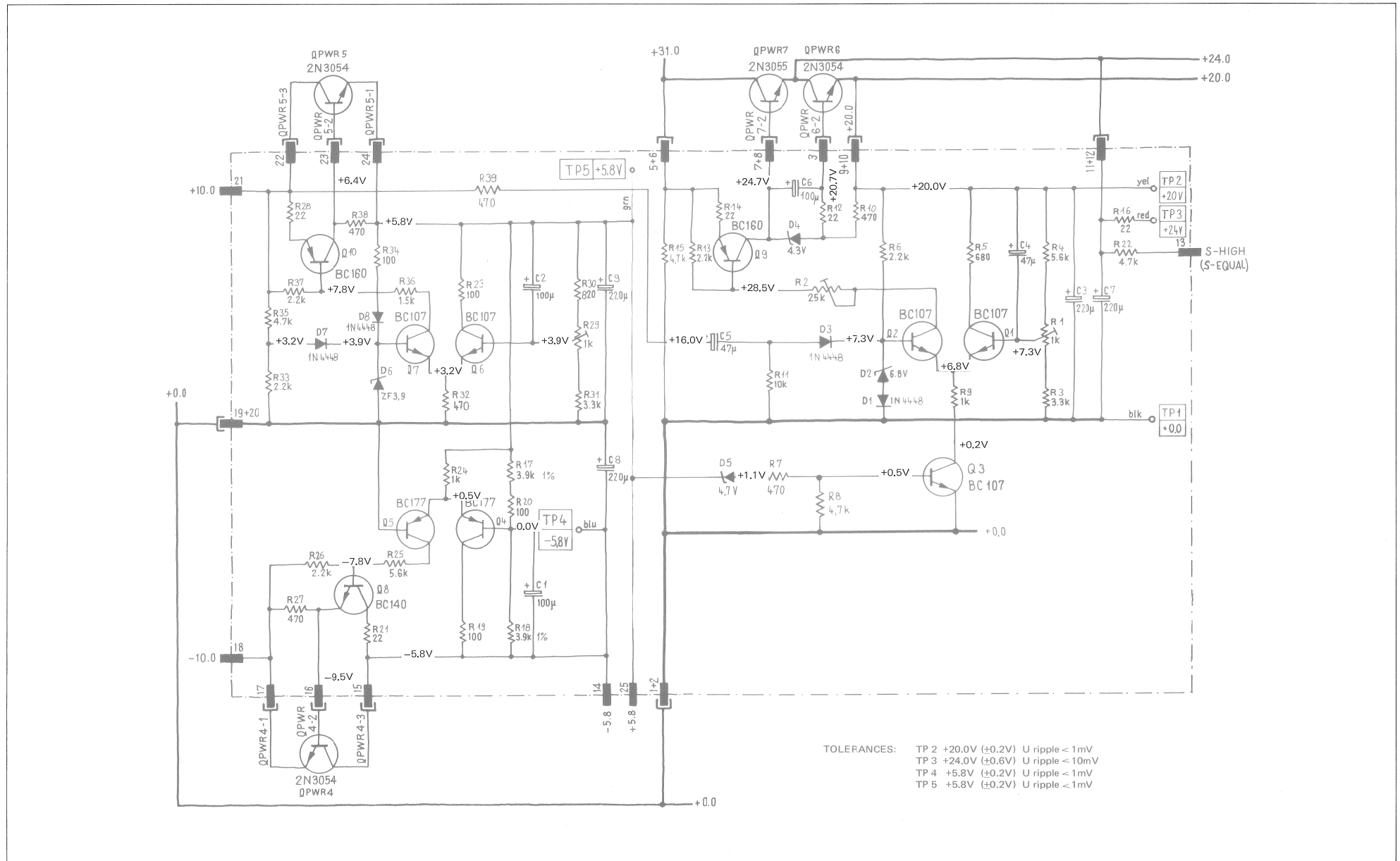

STABILIZER (TAPE TRANSPORT) 1.080.370-81 GR 20 EL 2

INDX	POS NO	PART NO	VALUE	SPECIFICATIONS/EQUIVALENT	MFR
C 01	59.22.3101	100 pF	-10%	12V EL	
C 02	59.22.3101				
C 03	59.25.4221	220 pF	-10%	25V EL	
C 04	59.22.5470	47 pF	-10%	25V EL	
C 05	59.22.5470				
C 06	59.25.3101	100 pF	-10%	16V EL	
C 07	59.25.5221	220 pF	-10%	40V EL	
C 08	59.25.3221	220 pF	-10%	16V EL	
C 09	59.25.3221	220 pF			
D 01	50.04.0125	1N4448		SI	
D 02	50.04.1102	6.8 V	5%	.40W Z	
D 03	50.04.0125	1N4448		SI	
D 04	50.04.1120	4.3 V	5%	.40W Z	
D 05	50.04.1123	4.7 V	5%	.40W Z	
D 06	50.04.1101	3.9 V	5%	.40W Z	
D 07	50.04.0125	1N4448		SI	
D 08	50.04.0125	1N4448		SI	
Q 01	50.03.0428	BC107A			
Q 02	50.03.0428	BC107A			
Q 03	50.03.0428	BC107A			
Q 04	50.03.0307	BC177A			
Q 05	50.03.0307	BC177A			
Q 06	50.03.0428	BC107A			
Q 07	50.03.0428	BC107A			
Q 08	50.03.0316	BC140-16			
Q 09	50.03.0315	BC160-16			
Q 10	50.03.0315	BC160-16			

INDX	DATE	NAME	
④			EL = Electrolytic
③			
②			
①	30.10.78	Schn/gv	

INDX	POS NO	PART NO	VALUE	SPECIFICATIONS/EQUIVALENT	MFR
R 01	58.01.7102	1 k	10%	.5W LIN	
R 02	58.01.7203	20 k	10%	.5W LIN	
R 03	57.41.4332	3.3 k	5%	.25W CF	
R 04	57.41.4562	5.6 k			
R 05	57.41.4681	680			
R 06	57.41.4222	2.2 k			
R 07	57.41.4471	470			
R 08	57.41.4472	4.7 k			
R 09	57.41.4102	1 k			
R 10	57.41.4471	470			
R 11	57.41.4103	10 k			
R 12	57.42.4220	22	5%	.33W CF	
R 13	57.41.4222	2.2 k	5%	.25W CF	
R 14	57.42.4220	22		.33W	
R 15	57.41.4472	4.7 k		.25W	
R 16	57.41.4220	22			
R 17	57.39.3901	3.9 k	1%	.25W MP	
R 18	57.39.3901	3.9 k			
R 19	57.41.4101	100	5%	.25W CF	
R 20	57.41.4101	100			
R 21	57.42.4220	22		.33W	
R 22	57.41.4472	4.7 k		.25W	
R 23	57.41.4101	100			
R 24	57.41.4102	1 k			
R 25	57.41.4562	5.6 k			
R 26	57.41.4222	2.2 k			
R 27	57.41.4471	470			
R 28	57.42.4220	22		.33W	
R 29	58.01.7102	1 k	10%	.5W LIN	
R 30	57.41.4821	820	5%	.25W CF	

INDX	DATE	NAME	
④			CF = Carbon-Film
③			MP = Metal-Film
②			
①	30.10.78	Schn/gv	

INDX	POS NO	PART NO	VALUE	SPECIFICATIONS/EQUIVALENT	MFR
R 31	57.41.4332	3.3 k	5%	.25W CF	
R 32	57.41.4471	470			
R 33	57.41.4222	2.2 k			
R 34	57.41.4101	100			
R 35	57.41.4472	4.7 k			
R 36	57.41.4152	1.5 k			
R 37	57.41.4222	2.2 k			
R 38	57.41.4471	470			
R 39	57.41.4471	470			
TP 1	54.01.0010	Jack 2mm		blk	
TP 2	54.01.0014			yel	
TP 3	54.01.0012			red	
TP 4	54.01.0016			blu	
TP 5	54.01.0015			grn	

INDX	DATE	NAME	
④			CF = Carbon-Film
③			
②			
①	30.10.78	Schn/gv	

STABILIZER 2 CHANNEL (AUDIO) 1.080.988

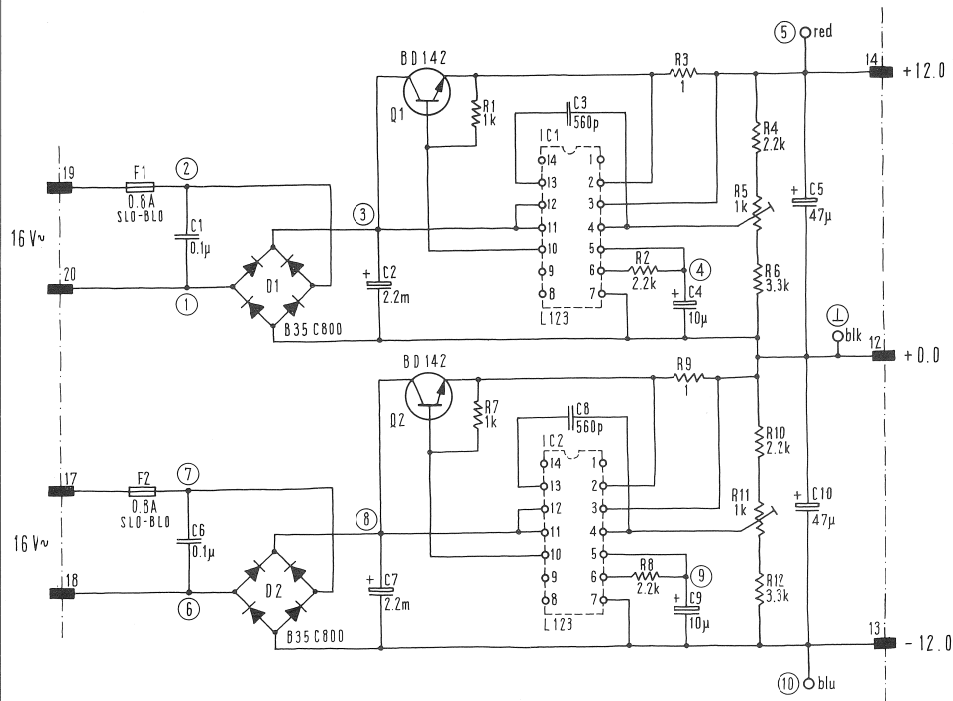

TEST POINTS	1	2	3	4	5	6	7	8	9	10	
V~	16	—	—	—	16	—	—	—	—	—	AC-voltmeter, min. 100 kΩ
V=	—	—	(+22)	+7.3	+12.0	—	—	(+10)	-4.7	-12.0	DC-voltmeter, min. 40 kΩ/V

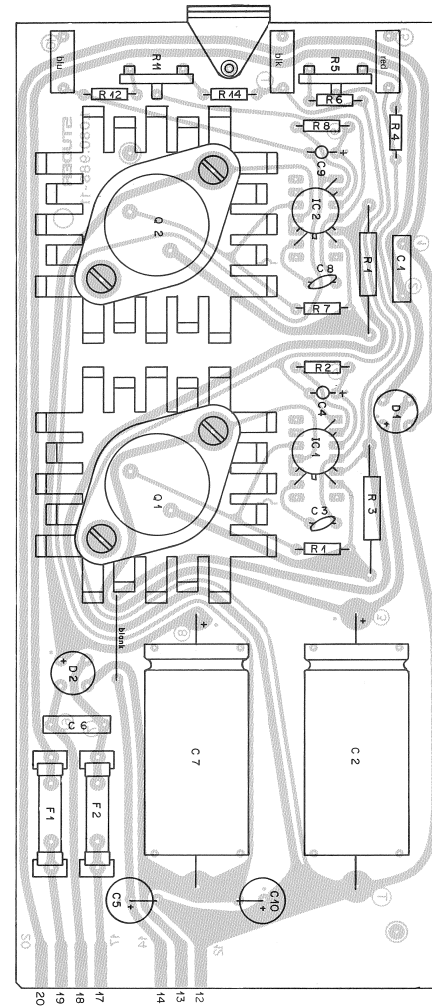

STABILIZER 4 CHANNEL (AUDIO) 1.080.964-81

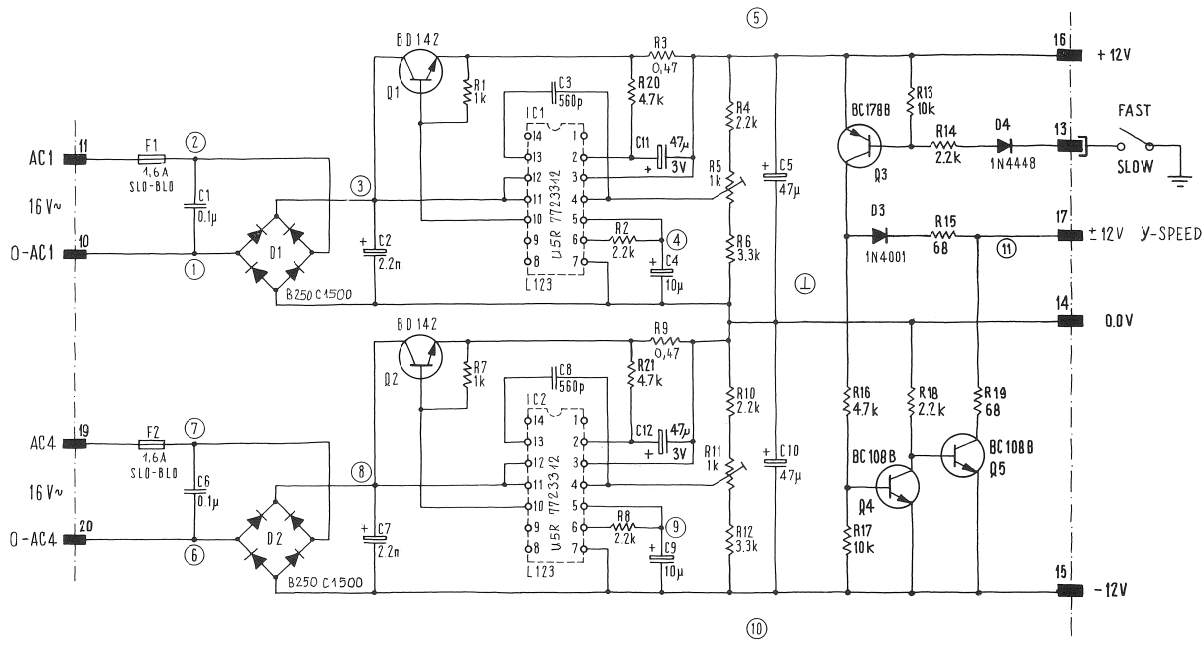

- | | |
|------------------------|------------------|
| ① } 16V _{eff} | ⑧ (+10V) |
| ② } (+22V) | ⑨ -4.7V |
| ③ } (+22V) | ⑩ -12.0V |
| ④ } +7.3V | ⑪ +11.4V AT SLOW |
| ⑤ } +12.0V | -12V AT FAST |
| ⑥ } 16V _{eff} | |
| ⑦ } 16V _{eff} | |

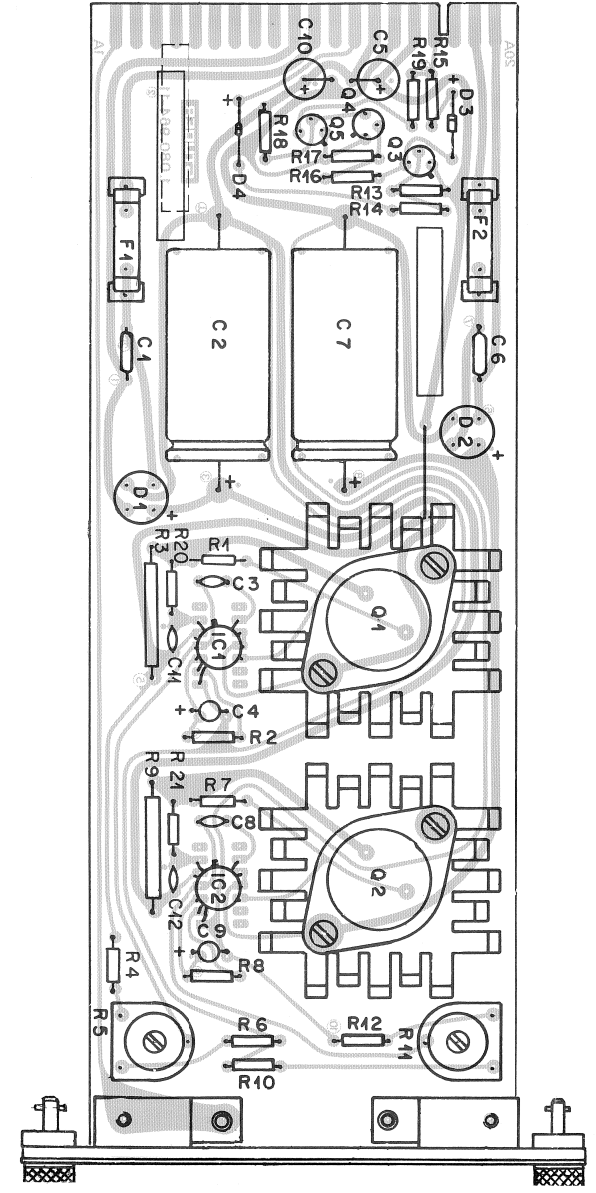

STABILIZER 4 CHANNEL (AUDIO) 1.080.964-81

Pos.	Bauteil No.	Bezeichnung	Stk.	Bemerkung
2)	C 1	59.31.4104 C 0,1 U. 20 %, 160 V, MPFPP	1	
	C 2	59.25.4222 C 2,2 N, 100 %, 25 V, EL	1	
	C 3	59.32.0561 C 560 F, 20 %, 500 V, KBR	1	
	C 4	59.30.4100 C 10 U. 50 %, 16 V, FA	1	
	C 5	59.27.4470 C 47 U. 50 %, 35 V, EL	1	
	C 6	59.31.4104 C 0,1 U. 20 %, 160 V, MPFPP	1	
	C 7	59.25.4222 C 2,2 N, 100 %, 25 V, EL	1	
	C 8	59.32.0561 C 560 F, 20 %, 500 V, KBR	1	
	C 9	59.30.4100 C 10 U. 50 %, 16 V, FA	1	
	C 10	59.27.4470 C 47 U. 50 %, 35 V, EL	1	
1)	C 11	59.30.1470 C 47 U. 50 %, 3 V, FA	1	
1)	C 12	59.30.1470 C 47 U. 50 %, 3 V, FA	1	
3)	D 1	70.01.0224 D B250 C1500	SI	1
3)	D 2	70.01.0224 D B250 C1500	SI	1
	D 3	50.04.0123 D 1 N 4001	SI	1
	D 4	50.04.0125 D 1 N 4448	SI	1
3)	F 1	50.01.0119 F 1600 M, 5 x 20	T	1
3)	F 2	50.01.0119 F 1600 M, 5 x 20	T	1
	IC 1	50.05.0119 IC USR 7723312, met.can.pack		1
	IC 2	50.05.0119 IC USR 7723312, met.can.pack		1

Änderungen ① 7.12.72 ② 19.3.73 ③ 2.7.74 ④ ⑤

STUDER Positionenliste
 REGENSDORF Stablisator-Einschub
 ZÜRICH

Kopie für: _____
 Ersetzt für: _____
 Ersetzt durch: PL 1.080.964 -81

Erstellt: 7.5.73 we
 Geprüft:
 Blatt: 1 Blätter: 2

Pos.	Bauteil No.	Bezeichnung	Stk.	Bemerkung
Q	Q 1	50.03.0475 Q SDT 9201	NPN	1
	Q 2	50.03.0475 Q SDT 9201	NPN	1
	Q 3	50.03.0306 Q BC 1788	PNP	1
	Q 4	50.03.0409 Q BC 1088	NPN	1
	Q 5	50.03.0409 Q BC 1088	NPN	1
R	R 1	57.41.4102 R 1,0k, 5%, 12W, CSCH		1
	R 2	57.41.4222 R 2,2k, 5%, 12W, CSCH		1
3)	R 3	57.56.5478 R 0,47, 10%, 4W, DR		1
	R 4	57.41.4222 R 2,2k, 5%, 12W, CSCH		1
	R 5	58.20.2102 R 1,0k, 20%, 8W, PCSCHE		1
	R 6	57.41.4332 R 3,3k, 5%, 12W, CSCH		1
	R 7	57.41.4102 R 1,0k, 5%, 12W, CSCH		1
	R 8	57.41.4222 R 2,2k, 5%, 12W, CSCH		1
3)	R 9	57.56.5478 R 0,47, 10%, 4W, DR		1
	R 10	57.41.4222 R 2,2k, 5%, 12W, CSCH		1
	R 11	58.20.2102 R 1,0k, 20%, 8W, PCSCHE		1
	R 12	57.41.4332 R 3,3k, 5%, 12W, CSCH		1
	R 13	57.41.4103 R 10k, 5%, 12W, CSCH		1
	R 14	57.41.4222 R 2,2k, 5%, 12W, CSCH		1
	R 15	57.41.4680 R 68, 5%, 12W, CSCH		1
	R 16	57.41.4472 R 4,7k, 5%, 12W, CSCH		1
	R 17	57.41.4102 R 1,0k, 5%, 12W, CSCH		1
	R 18	57.41.4222 R 2,2k, 5%, 12W, CSCH		1
	R 19	57.41.4680 R 68, 5%, 12W, CSCH		1
①	R 20	57.41.4472 R 4,7k, 5%, 12 W, CSCH		1
①	R 21	57.41.4472 R 4,7k, 5%, 12 W, CSCH		1

Änderungen ① 7.12.72 ② ③ 2.7.74 ④ ⑤

STUDER Positionenliste
 REGENSDORF Stablisator-Einschub
 ZÜRICH

Kopie für: _____
 Ersetzt für: _____
 Ersetzt durch: PL 1.080.964 -81

Erstellt: 31.5.1972
 Geprüft:
 Blatt: 2 Blätter: 2

COMMAND SWITCH BOARD 1.080.275 GR 17

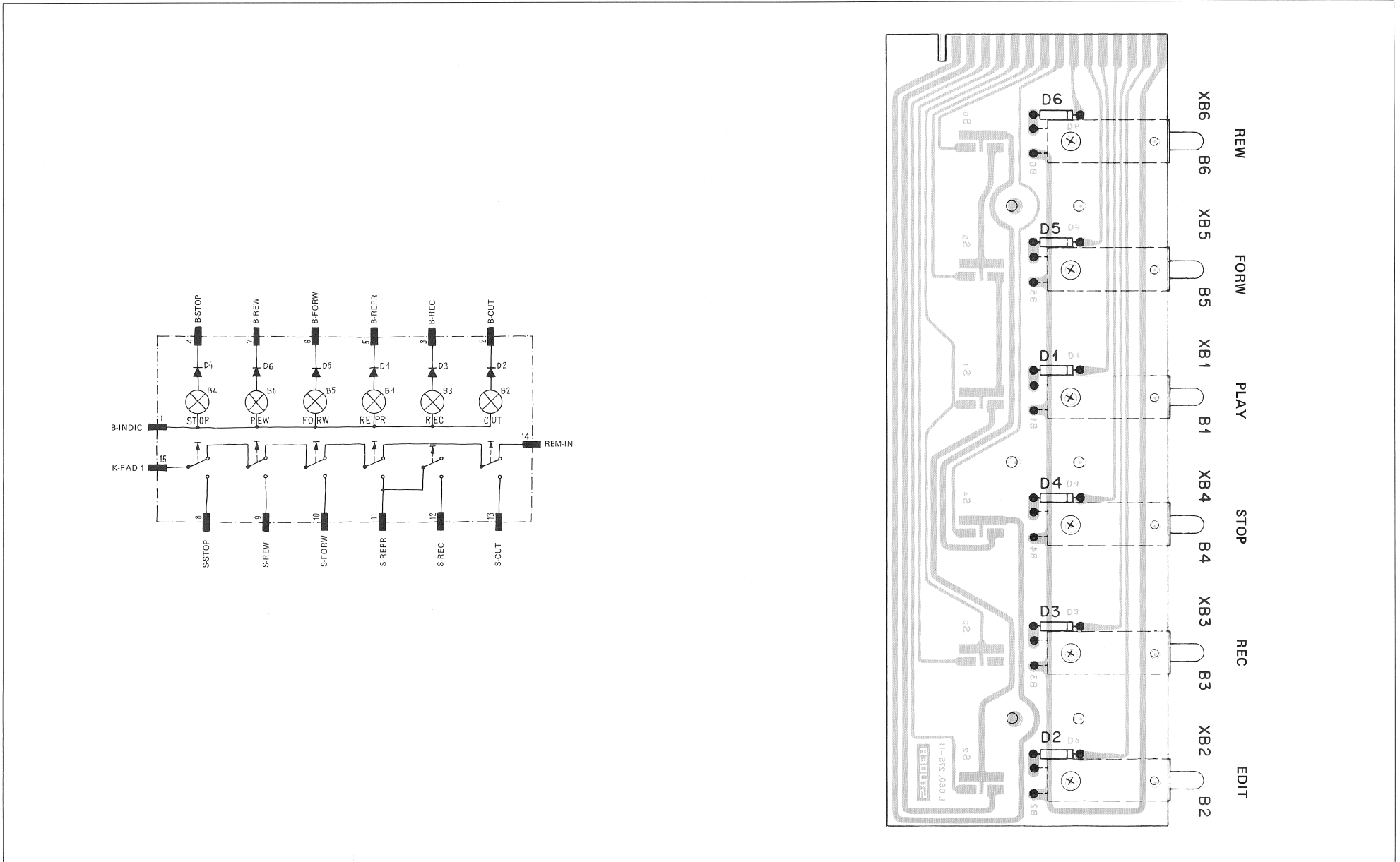

SPEED CONVERTER BOARD 1.080.979-81

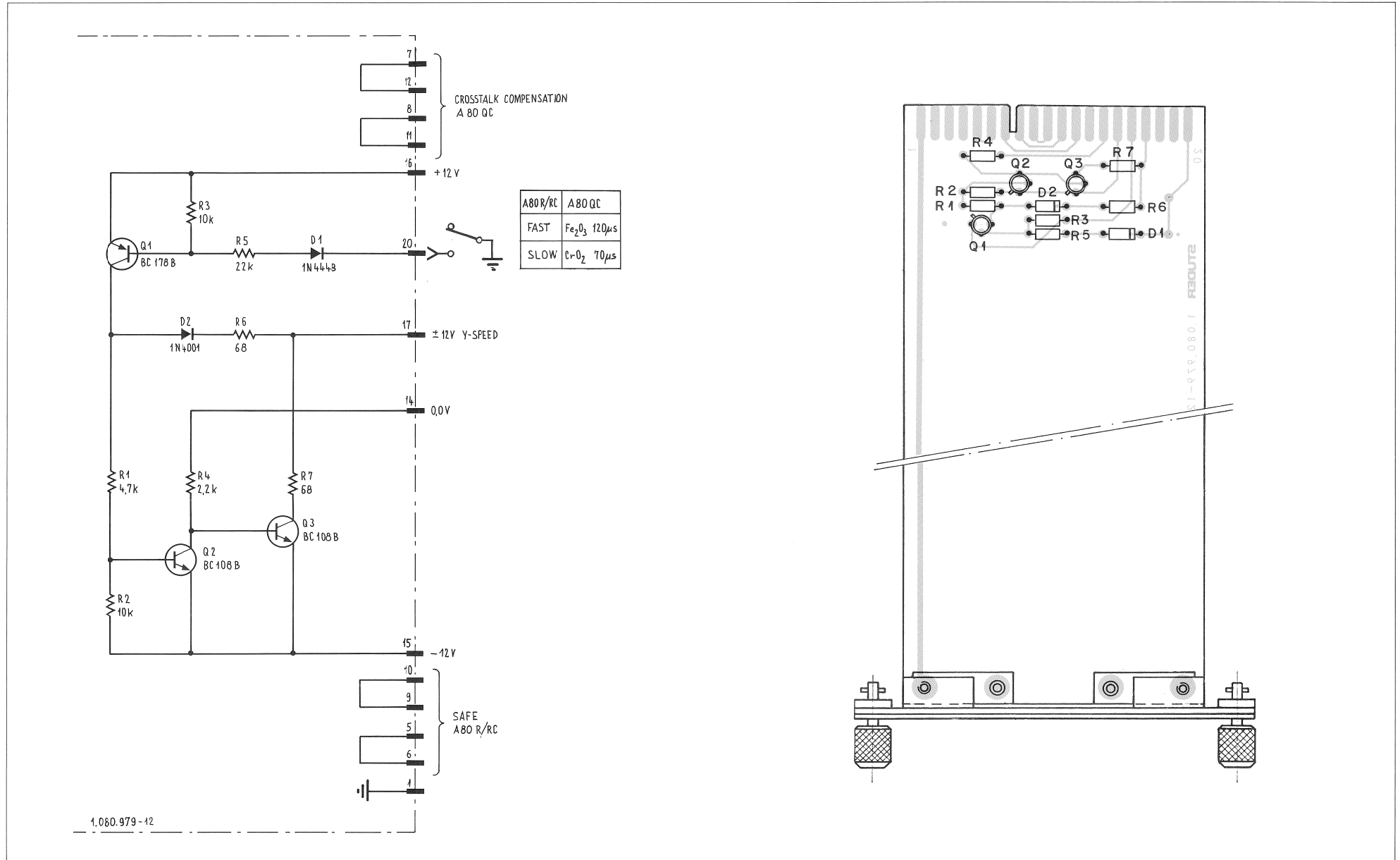

BASIS BOARD/COUNTER 1.228.812 GR 18

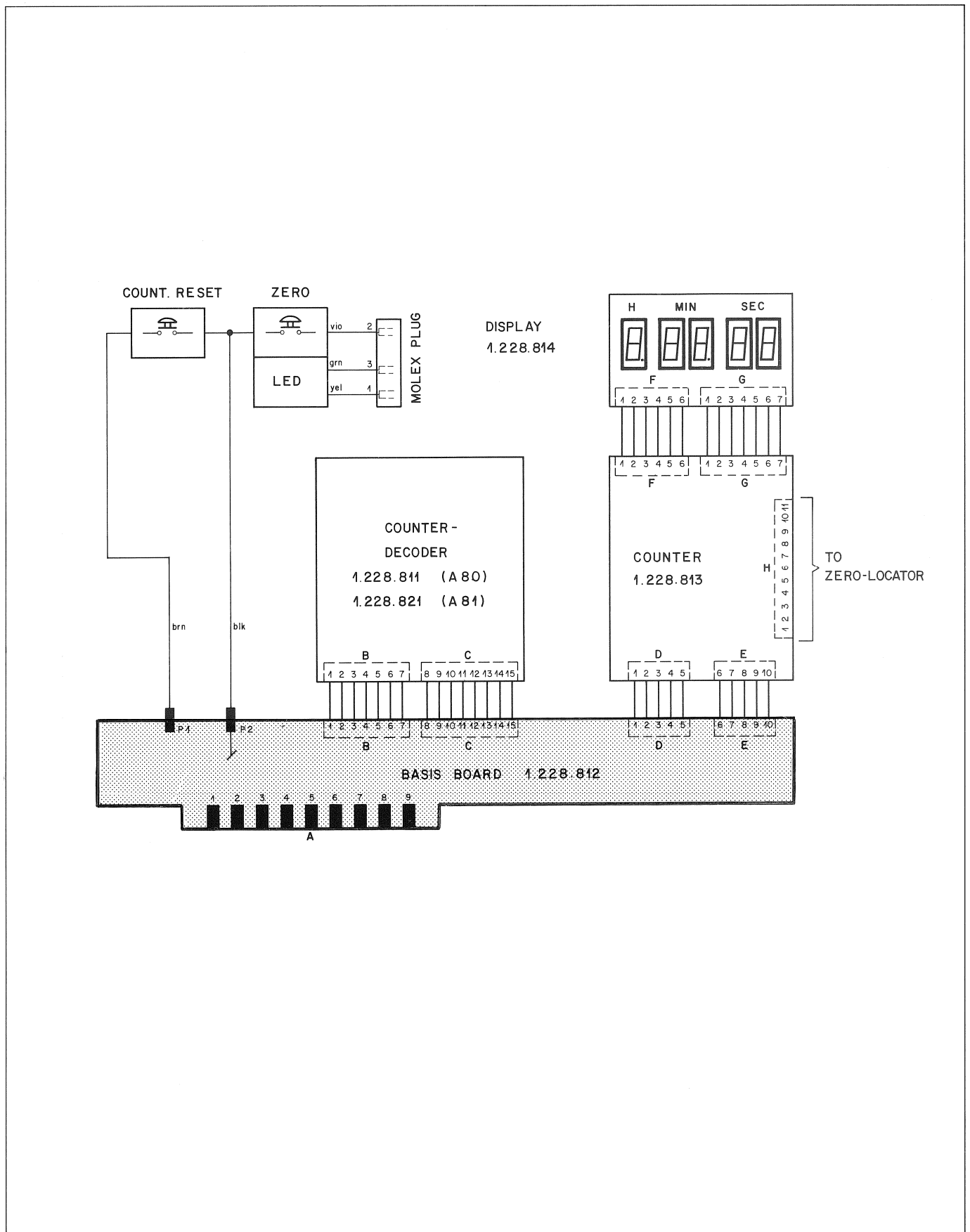

BASIS BOARD/COUNTER 1.228.812 GR 18

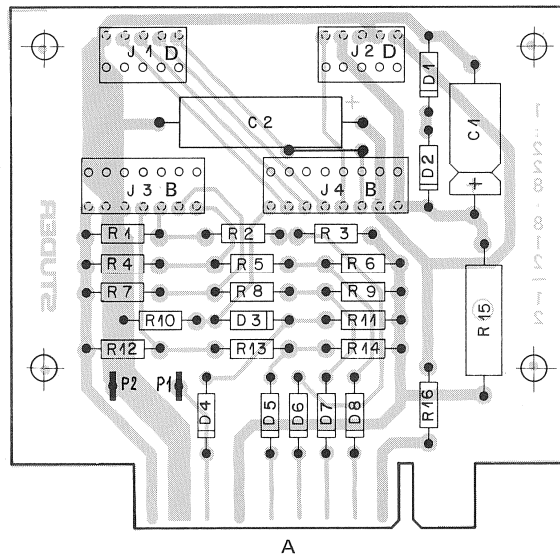

BASIS BOARD/COUNTER 1.228.812 GR 18

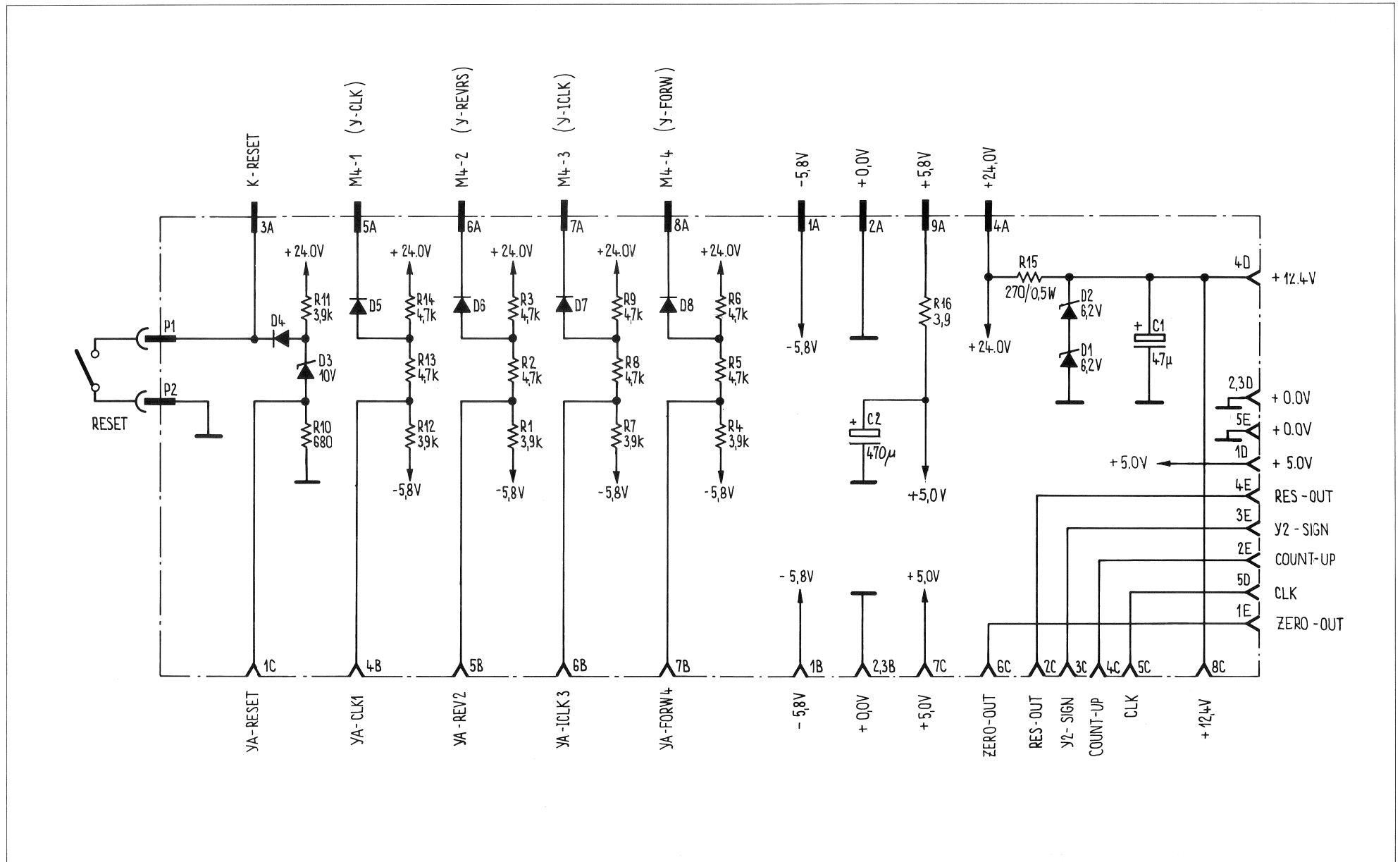

BASIS BOARD/COUNTER 1.228.812 GR 18

Pos.	Bauteil No.	Bezeichnung	Stk.	Bemerkung
(2) C 1	59.25.3470	C 47 U -10% 16 V TA	1	
C 2	59.25.1471	C 470 U -10% 6 V EK	1	
D 1	50.04.1118	D 6,2V 5% .4W	2	
D 2	50.04.1118	D	1	
D 3	50.04.1114	D 10V	1	
D 4	50.04.0109	D N 103	1	
D 5	50.04.0109	D	1	
D 6	50.04.0109	D	1	
D 7	50.04.0109	D	1	
D 8	50.04.0109	D	1	
J 1	54.01.0228	J Buchsenleiste 5-Pol.	1	
J 2	54.01.0228	J 5-Pol.	1	
J 3	54.01.0218	J 7-Pol.	1	
J 4	54.01.0209	J 8-Pol.	1	
R 1	57.41.4392	R 3,9K 5% .25W CSCH	1	
R 2	57.41.4472	R 4,7K	1	
R 3	57.41.4472	R 4,7K	1	
R 4	57.41.4392	R 3,9K	1	
R 5	57.41.4472	R 4,7K	1	
R 6	57.41.4472	R 4,7K	1	
R 7	57.41.4392	R 3,9K	1	
R 8	57.41.4472	R 4,7K	1	
R 9	57.41.4472	R 4,7K	1	
R 10	57.41.4681	R 680	1	
R 11	57.41.4392	R 3,9K	1	
R 12	57.41.4392	R 3,9K	1	
R 13	57.41.4472	R 4,7K	1	
R 14	57.41.4472	R 4,7K	1	
(1) R 15	57.11.4271	R 270 5% .5 W	1	
(2) R 16	57.11.4399	R 3,9 5% .25W CSCH	1	
Änderungen ① 24.1.78 ② 18.9.78 ③ ④ ⑤				

COUNTER DECODER 1.228.811 GR 18

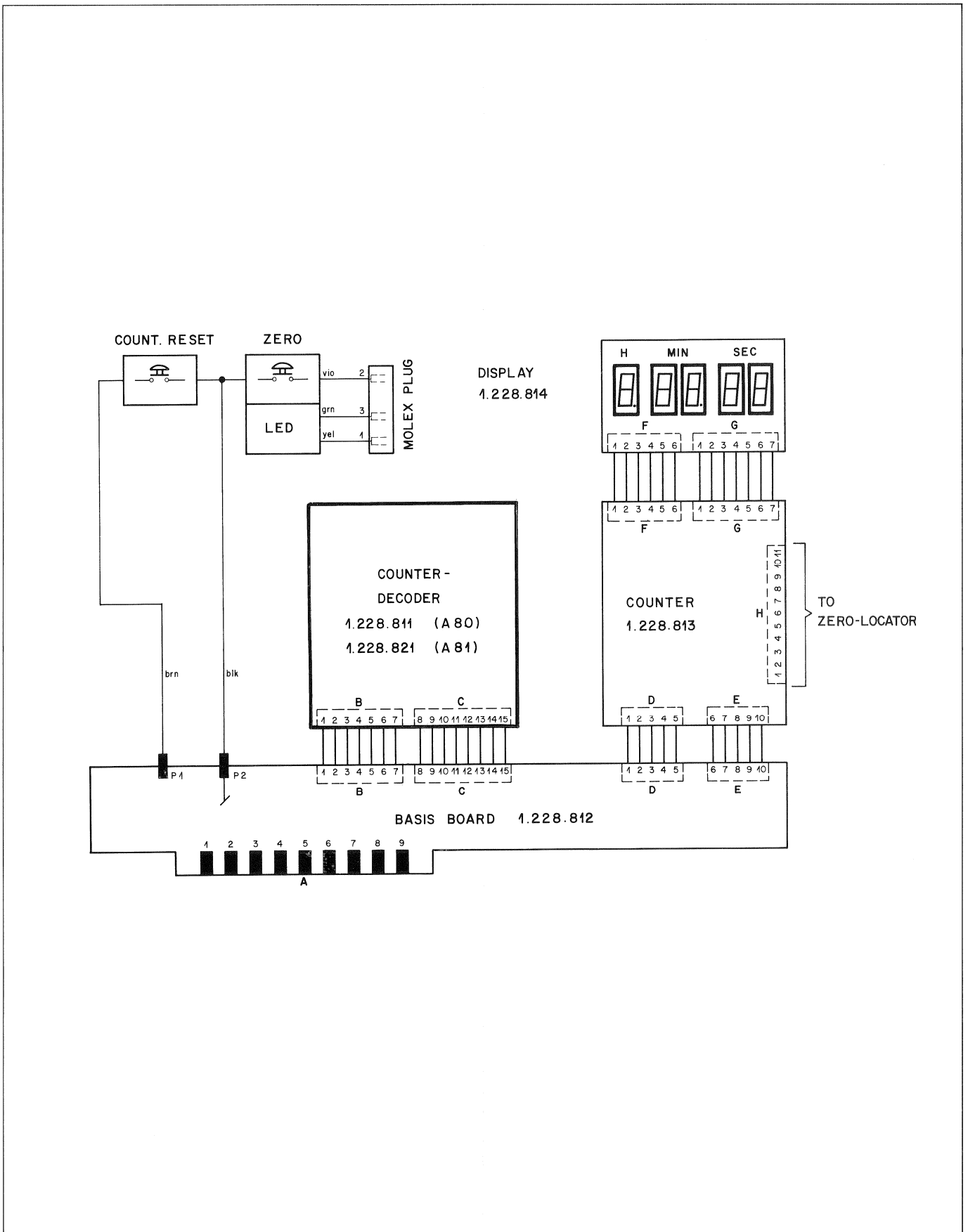

COUNTER DECODER 1.228.811 GR 18

COUNTING DIRECTION POS +NEG
ONLY POS

TAPE SPEED 15/30 ips
7.5/15 ips

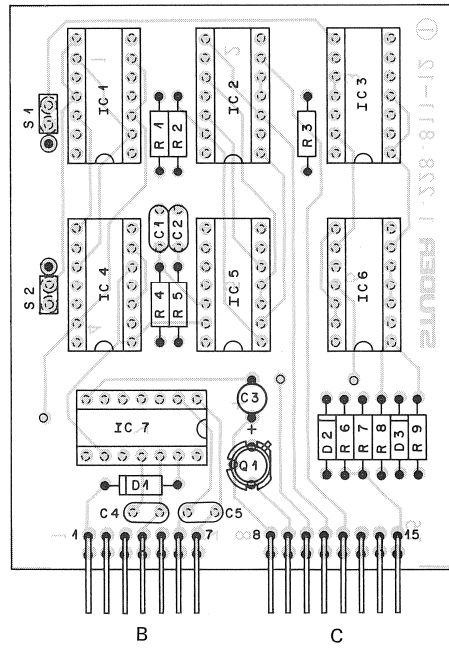

COUNTER DECODER 1.228.811 GR 18

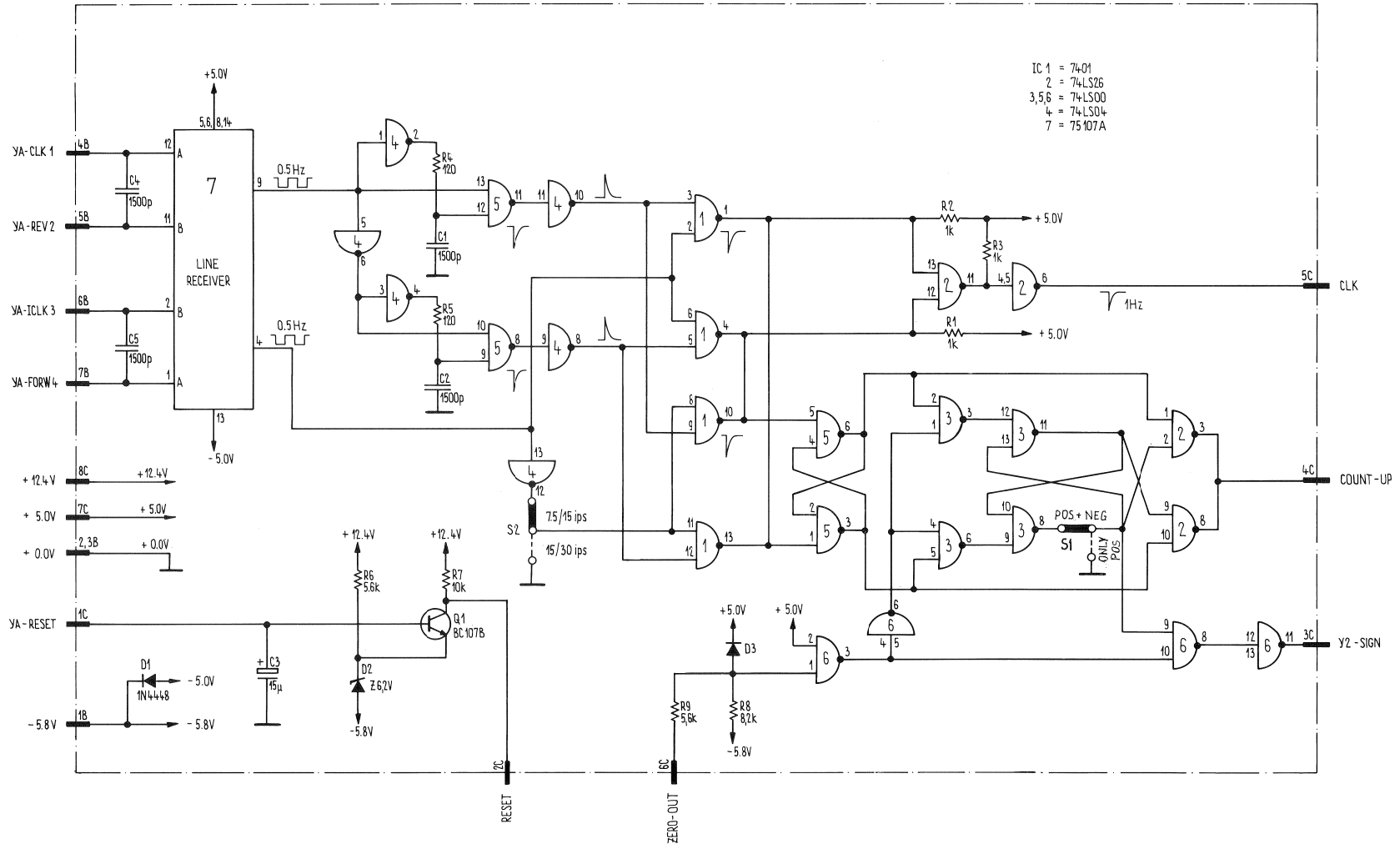

COUNTER DECODER 1.228.811 GR 18

Pos.	Beuteil No.	Berechnung	Stk.	Bemerkung
C 01	59.32.4152	C 1,5 N, 50V KBR	1	
C 02	59.32.4152	C 1,5 N,	1	
C 03	59.36.2150	C 1,5 D, 20% 10V TA	1	
C 04	59.32.4152	C 1,5 N, 50V KBR	1	
C 05	59.32.4152	C 1,5 N,	1	
D 01	50.04.0109	D 1 N 4448	SI	1
D 02	50.04.1118	D 6,2 V 5% .4W Z	1	
D 03	50.04.0109	D 1 N 4448	SI	1
IC 1	50.05.0136	IC SN 7401	1	
IC 2	50.06.0026	IC SN 74 LS 26	1	
IC 3	50.06.0000	IC SN 74 LS 00	1	
IC 4	50.06.0004	IC SN 74 LS 04	1	
IC 5	50.06.0000	IC SN 74 LS 00	1	
IC 6	50.06.0000	IC SN 74 LS 00	1	
IC 7	50.05.0228	IC SN 75107 A	1	
Q 01	50.03.0408	Q BC 107 B	1	
R 01	57.02.5102	R 1 K, 10%, .25W, CMA	1	
R 02	57.02.5102	R 1 K,	1	
R 03	57.02.5102	R 1 K,	1	
R 04	57.02.5121	R 120 ,	1	
R 05	57.02.5121	R 120 ,	1	
R 06	57.02.5562	R 5,6 K,	1	
R 07	57.02.5103	R 10 K,	1	
R 08	57.02.5822	R 8,2 K,	1	
R 09	57.02.5562	R 5,6 K,	1	
XIC	53.03.0167	XIC DT, 14-Pol.	7	
XD	50.03.9921	XD TG-Unterlage	1	
Anmerkungen ① 23.6.76 ② ③ ④ ⑤				

COUNTER 1.228.813 DISPLAY 1.228.814 GR 18

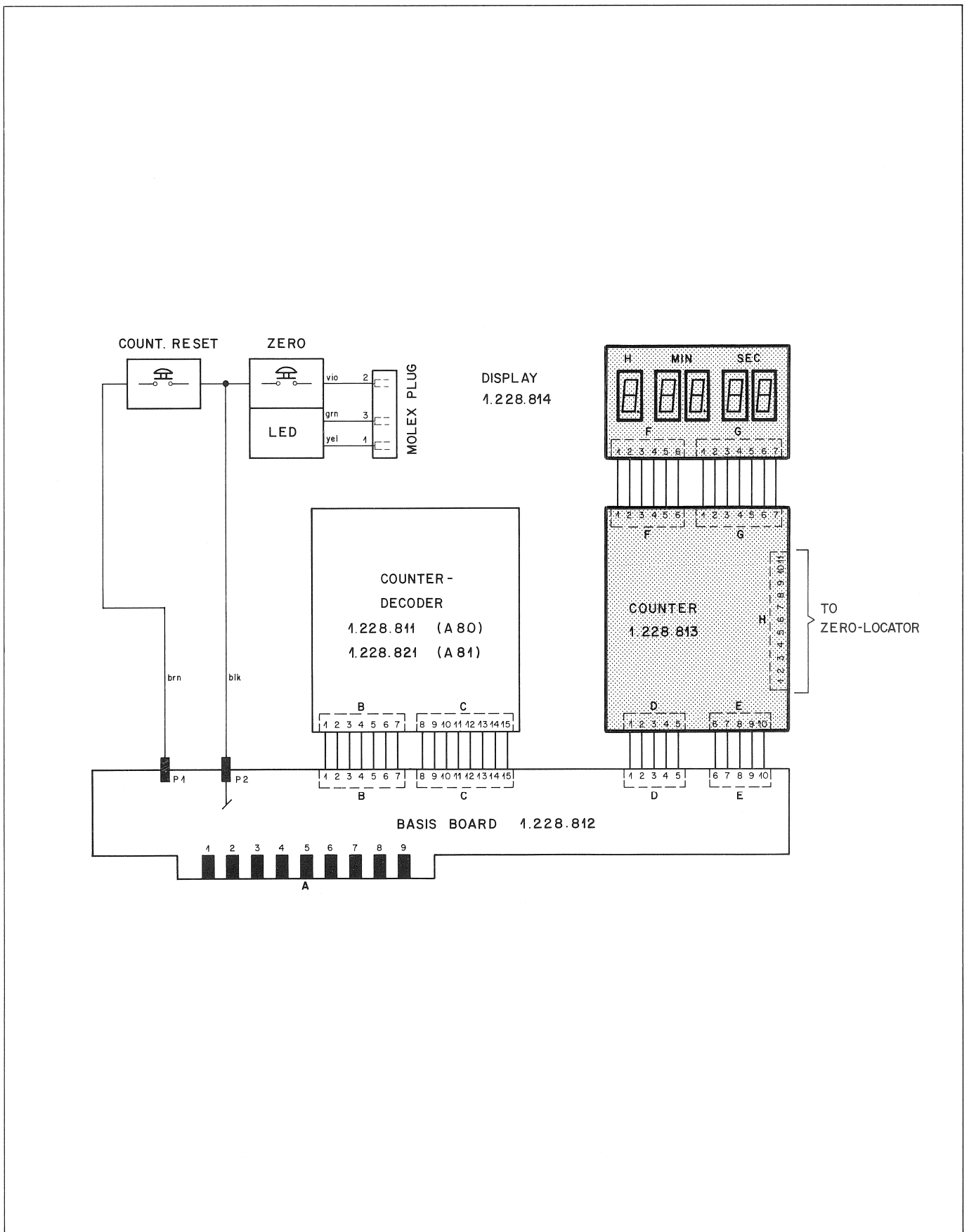

COUNTER 1.228.813

DISPLAY 1.228.814

GR 18

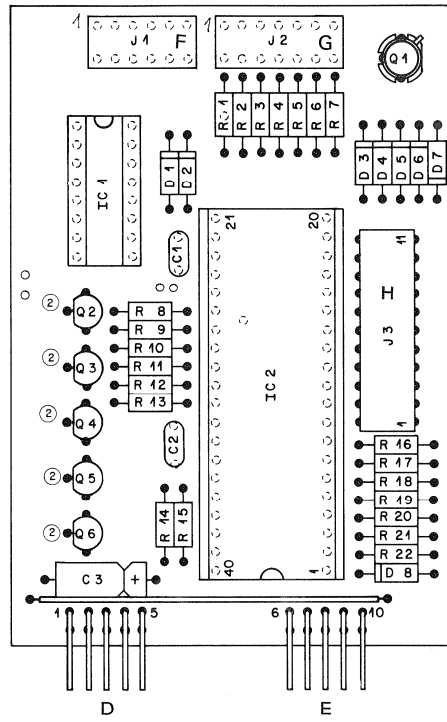
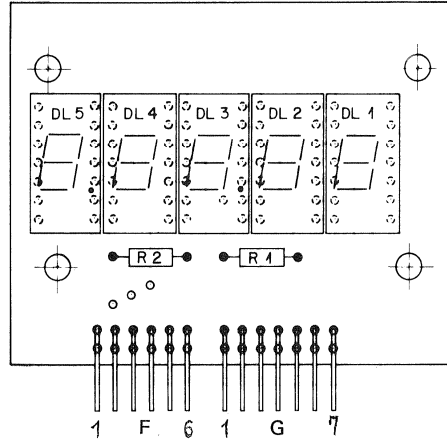

COUNTER 1.228.813 DISPLAY 1.228.814 GR 18

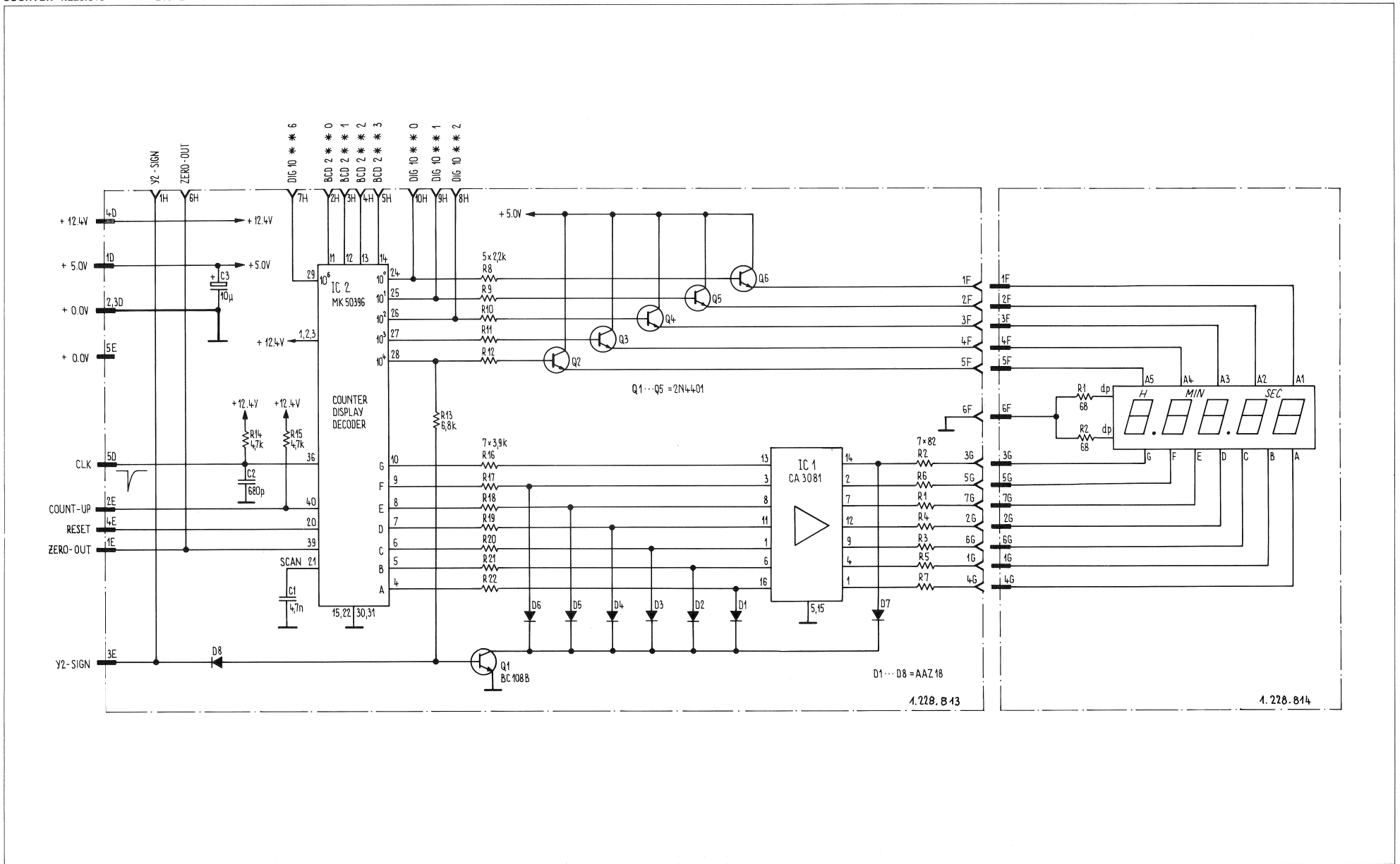

COUNTER 1.228.813 DISPLAY 1.228.814 GR 18

Pos.	Bauteil No.	Bezeichnung	Stk.	Bemerkung
C 01	59.32.3472	C 4.7 N, +100% 40V KER	1	
C 02	59.32.2681	C 680 F, ± 10%	1	
C 03	59.25.4100	C 10 U, +100% 25V TA	1	
D 01	50.04.0954	D AA2 18	GR 1	
D 02	50.04.0954	D AA2 18	1	
D 03	50.04.0954	D AA2 18	1	
D 04	50.04.0954	D AA2 18	1	
D 05	50.04.0954	D AA2 18	1	
D 06	50.04.0954	D AA2 18	1	
D 07	50.04.0109	D 1 N 4448	SI 1	
D 08	50.04.0954	D AA2 18	GB 1	
IC 1	50.05.0229	IC CA 3081 (RCA)	1	
IC 2	50.99.0121	IC MK 50396 (Mastek)	1	
J 01	54.01.0238	J Buchsenleiste 6-Pol.	1	
J 02	54.01.0263	J Buchsenleiste 7-Pol.	1	
J 03	54.01.0308	J Buchsenleiste 11-Pol.	1	
Q 01	50.03.0409	Q MC 108 B	1	
Q 02	50.03.0340	Q 2 N 4401	1	
Q 03	50.03.0340	Q 2 N 4401	1	
Q 04	50.03.0340	Q 2 N 4401	1	
Q 05	50.03.0340	Q 2 N 4401	1	
Q 06	50.03.0340	Q 2 N 4401	1	
R 01	57.02.5820	R 82 , 10% .25W CMA	1	
R 02	57.02.5820	R 82 ,	1	
R 03	57.02.5820	R 82 ,	1	
R 04	57.02.5820	R 82 ,	1	
R 05	57.02.5820	R 82 ,	1	
R 06	57.02.5820	R 82 ,	1	
R 07	57.02.5820	R 82 ,	1	
R 08	57.02.5222	R 2.2 K, 10% .25W CMA	1	
R 09	57.02.5222	R 2.2 K,	1	
R 10	57.02.5222	R 2.2 K,	1	
R 11	57.02.5222	R 2.2 K,	1	
R 12	57.02.5222	R 2.2 K,	1	
R 13	57.02.5472	R 6.8 K,	1	
R 14	57.02.5472	R 4.7 K,	1	
R 15	57.02.5472	R 4.7 K,	1	
R 16	57.02.5392	R 3.9 K,	1	
R 17	57.02.5392	R 3.9 K,	1	
R 18	57.02.5392	R 3.9 K,	1	
R 19	57.02.5392	R 3.9 K,	1	
R 20	57.02.5392	R 3.9 K,	1	
R 21	57.02.5392	R 3.9 K,	1	
R 22	57.02.5392	R 3.9 K,	1	
XIC	53.03.0168	XIC DIL 16-Pol.	1	
XIC	53.03.0172	XIC 40-Pol.	1	
X >	50.03.9921	X G 75-Unterlage	6	
Änderungen ① 21.6.76 ② ③ ④ ⑤				

COUNTER 1.228.813

Pos.	Bauteil No.	Bezeichnung	Stk.	Bemerkung
DL 1	73.01.0120	7 - Segment Display	1	
DL 2	73.01.0120		1	
DL 3	73.01.0120		1	
DL 4	73.01.0120		1	
DL 5	73.01.0120		1	
R 1	57.02.5660	R 68 10% .25W CMA	1	
R 2	57.02.5660		1	
X IC	53.03.0167	DIL - 14 Pol.	5	
Änderungen ① ② ③ ④ ⑤				

DISPLAY 1.228.814

CONTENTS

DESCRIPTION	SCHEMATIC NO.		SECTION/PAGE
GENERAL			6
STUDER ELECTRONIC CARDS			6/3
PRESENTATION OF GROUPS			6/5
REMOTE MODE CONTROL		GR 22 EL 22	6/6
CUTTER CONTROL ASSEMBLY		GR 19 EL 21	6/7
POWER SUPPLY UNIT	1.080.320/322	GR 1/2	6/8
STABILIZER (TAPE TRANSPORT)	1.080.370-81	GR 20 EL 2	6/11
STABILIZER 2 CHANNEL (AUDIO)	1.080.988		6/15
STABILIZER 4 CHANNEL (AUDIO) A80 RTQ	1.080.964-81		6/17
COMMAND SWITCH BOARD	1.080.275	GR 17	6/19
SPEED CONVERTER BOARD	1.080.979-81		6/21
BASIS BOARD/COUNTER	1.228.812	GR 18	6/23
COUNTER DECODER	1.228.811	GR 18	6/27
COUNTER	1.228.813	GR 18	6/31
DISPLAY	1.228.814	GR 18	6/31
TAPE TRANSPORT CONTROL			7
TAPE TRANSPORT CONTROL/BLOCK DIAGRM A80 R			7/3
PRESSURE ROLLER ASSEMBLY	1.080.124	GR 15 EL 1	7/4
TAPE TENSION CONTROL ASSEMBLY L/R	1.080.142/146	GR 11/12 EL 1	7/5
OPTICAL TAPE END SENSOR		GR 30 EL 1	7/6
TAPE MOVE AND DIRECTION SENSOR UNIT	1.080.181	GR 14 EL 1/2	7/7
CONTACTOR	1.080.381	GR 20 EL 4	7/11
SPOOLING MOTOR CONTROL 1/4" + 1/2" (7,5 - 15 ips)	1.080.383	GR 20 EL 5	7/15
SPOOLING MOTOR CONTROL 1/4" + 1/2" (15 - 30 ips)	1.080.385-81	GR 20 EL 5	7/19
CAPSTAN SERVO WITH VARIABLE SPEED CONTROL	1.080.372/374/377	GR 20 EL 6	7/23
IC DECODER AND DRIVERS	1.080.391	GR 20 EL 8	7/27
IC MEMORY AND COUNTER	1.080.393	GR 20 EL 9	7/31
ATTENUATOR AND PREAMPLIFIER	1.080.396	GR 20 EL 10	7/35
ZERO LOCATOR	1.080.395	GR 20 EL 11	7/39
AUDIO			8
AUDIO BLOCK DIAGRAM WITH STANDARD CONNECTOR PANEL			8/3
AUDIO BLOCK DIAGRAM WITH MONO/STEREO CONNECTOR PANEL			8/4
AUDIO BLOCK DIAGRAM WITH VU-METER PANEL			8/5
AUDIO BASIS BOARD / 2 CHANNEL	1.080.980		8/7
AUDIO BASIS BOARD / 4 CHANNEL A80 RTQ	1.080.962		8/8
WIRING DIAGRAMS HEADBLOCK ASSEMBLIES			8/9
REPRODUCE AMPLIFIER	1.080.986		8/11
RECORD AMPLIFIER	1.080.982		8/15
OSCILLATOR STEREO	1.080.984		8/19
OSCILLATOR 2 TRACK	1.080.987		8/23
OSCILLATOR 4 CHANNEL A80 RTQ	1.080.965		8/27
PILOT TONE AMPLIFIER MK II	1.080.932		8/29
CONNECTION PANEL (STANDARD) USA/EURO	1.080.989/997		8/33
CONNECTION PANEL (MONO/STEREO) USA/EURO	1.080.994/998		8/37
CONNECTION PANEL (VU-METER PANEL) USA/EURO	1.080.993/991		8/41
VU-METER PANEL	1.080.950		8/43
EARLIER SCHEMATICS			9

TAPE TRANSPORT CONTROL/BLOCK DIAGRAM A80R

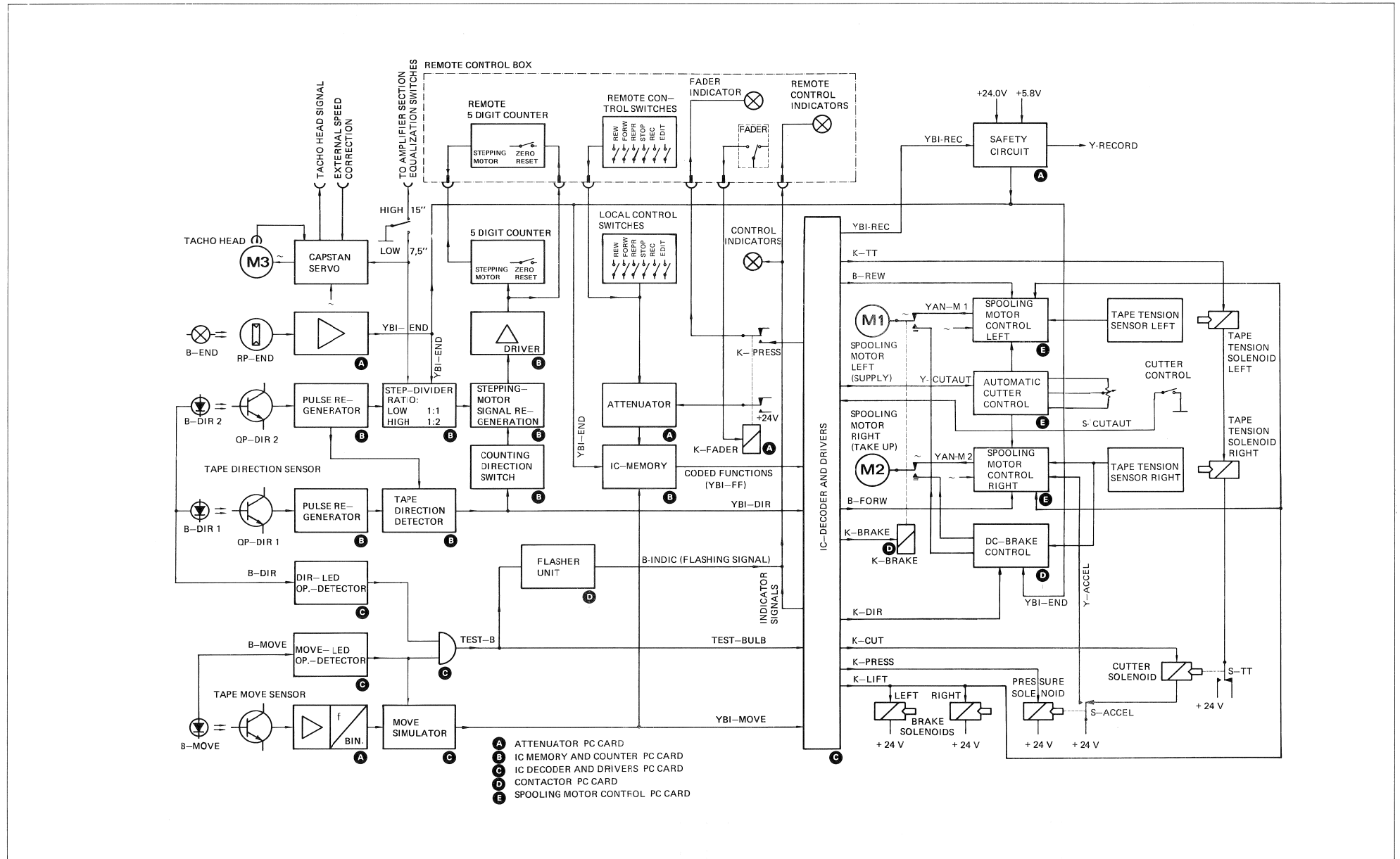

PRESSURE ROLLER ASSEMBLY 1.080.124 GR 15 EL 1

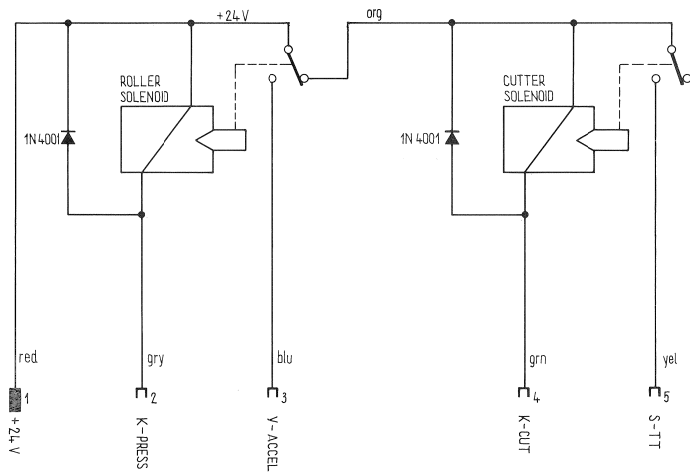

7.5/15 ips

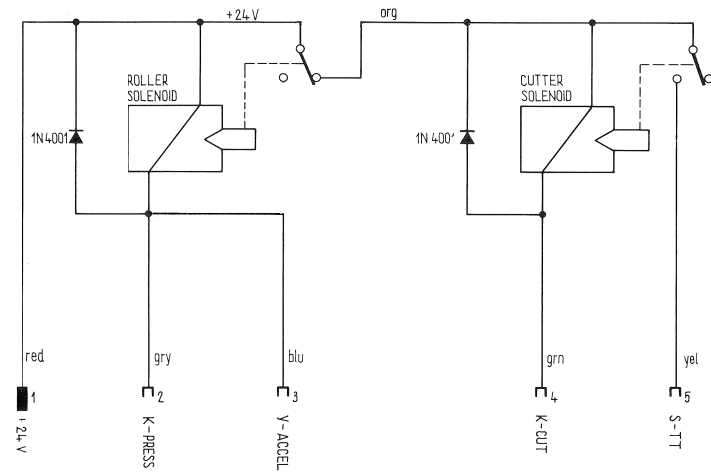

15/30 ips

TAPE TENSION CONTROL ASSEMBLY LEFT 1.080.142 GR 11 EL 1 / RIGHT 1.080.146 GR 12 EL 1

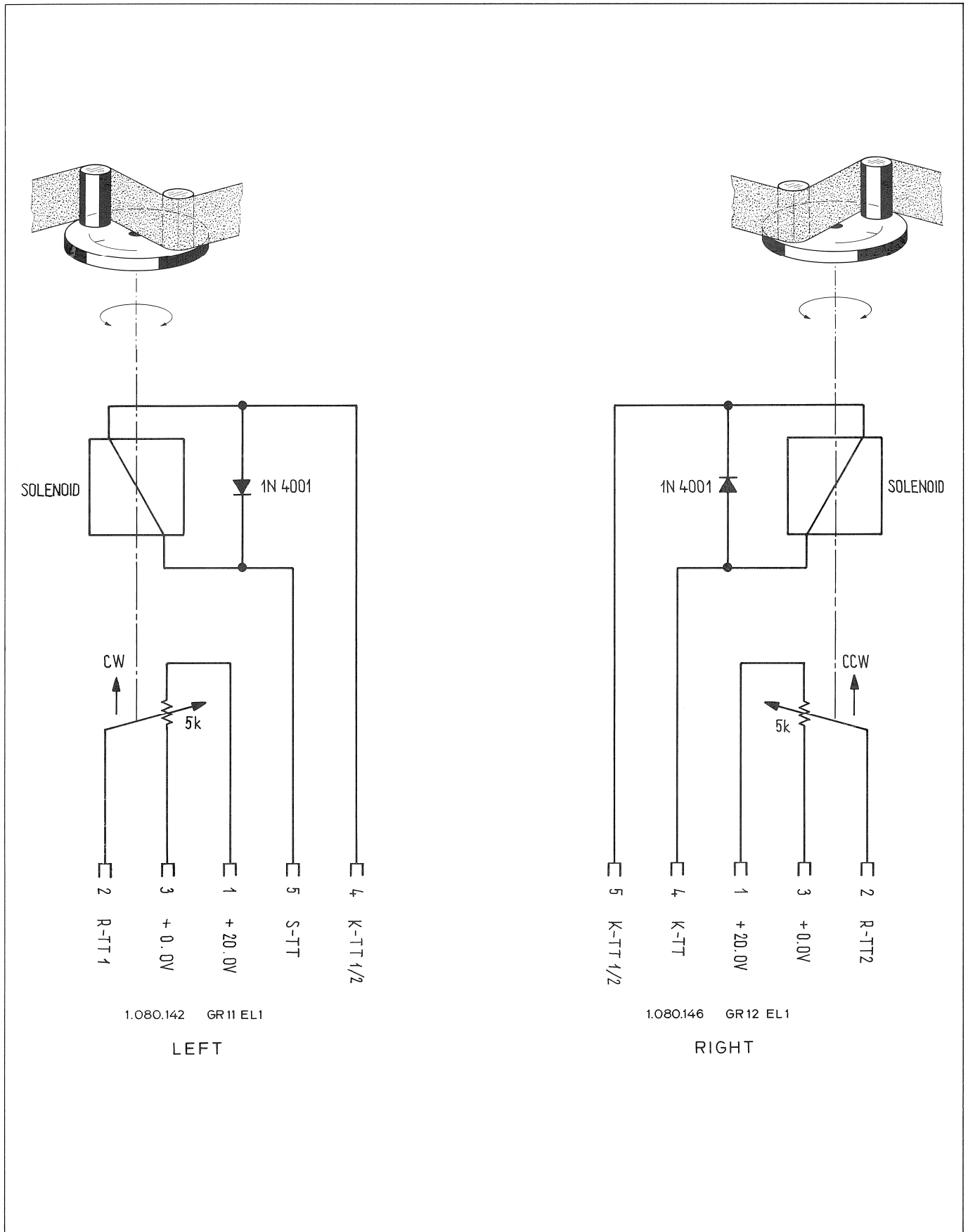

OPTICAL TAPE END SENSOR GR13 EL1

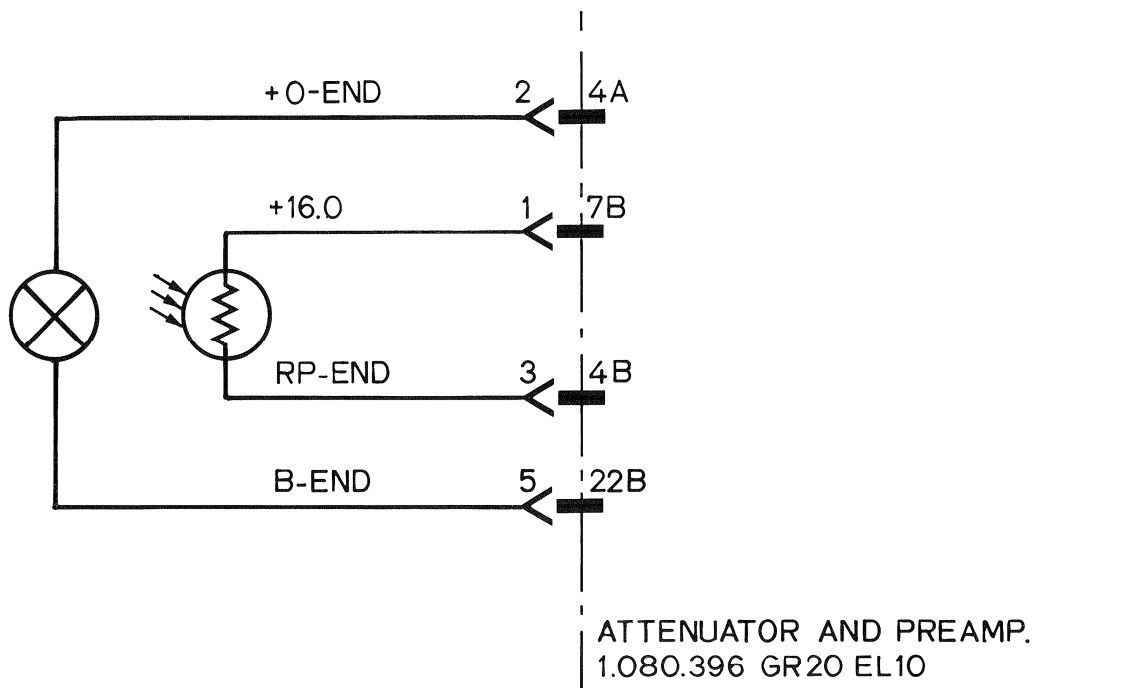

TAPE MOVE AND DIRECTION SENSOR UNIT 1.080.181

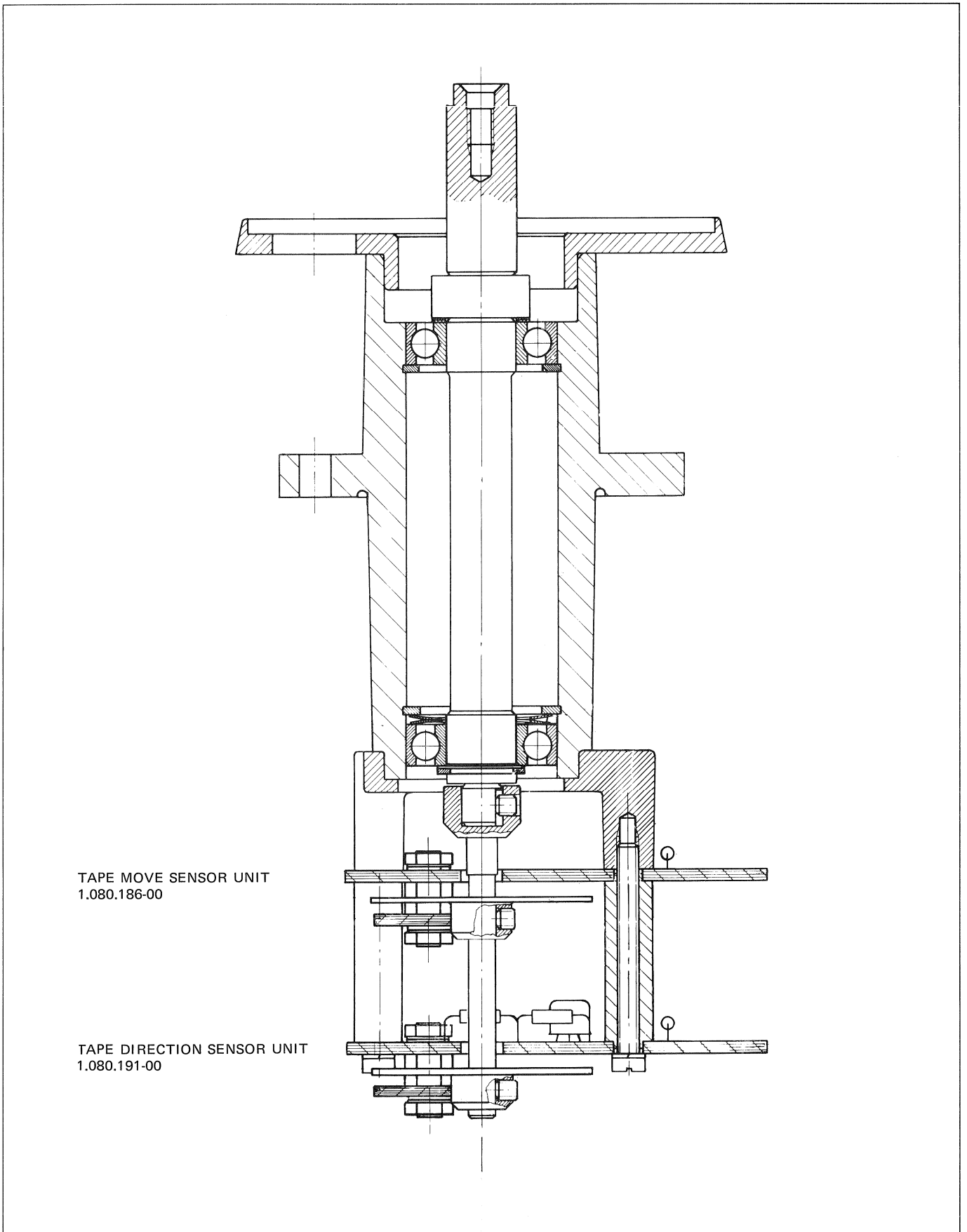

TAPE MOVE SENSOR UNIT
1.080.186-00

TAPE DIRECTION SENSOR UNIT
1.080.191-00

TAPE MOVE AND DIRECTION SENSOR UNIT 1.080.181

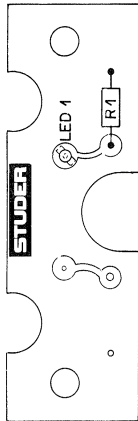

TAPE SENSOR 1.080.188

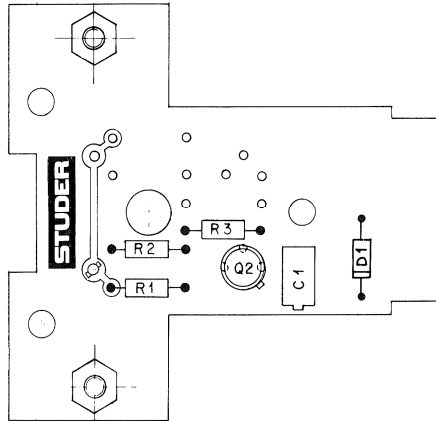

TAPE MOVE SENSOR 1.080.186

TAPE MOVE SENSOR UNIT 1.080.186-00 GR14 EL1

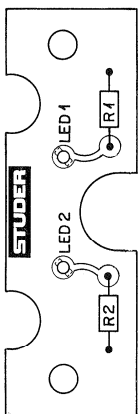

TAPE SENSOR 1.080.187

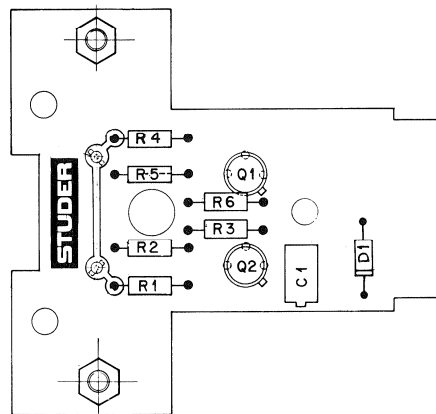

TAPE DIRECTION SENSOR 1.080.191

TAPE DIRECTION SENSOR UNIT 1.080.191-00 GR14 EL2

TAPE MOVE AND DIRECTION SENSOR UNIT 1.080.181

TAPE MOVE AND DIRECTION SENSOR UNIT 1.080.181 CONSISTING OF:

- TAPE MOVE SENSOR UNIT 1.080.186-00 GR 14 EL 1
- TAPE DIRECTION SENSOR UNIT 1.080.191-00 GR 14 EL 2

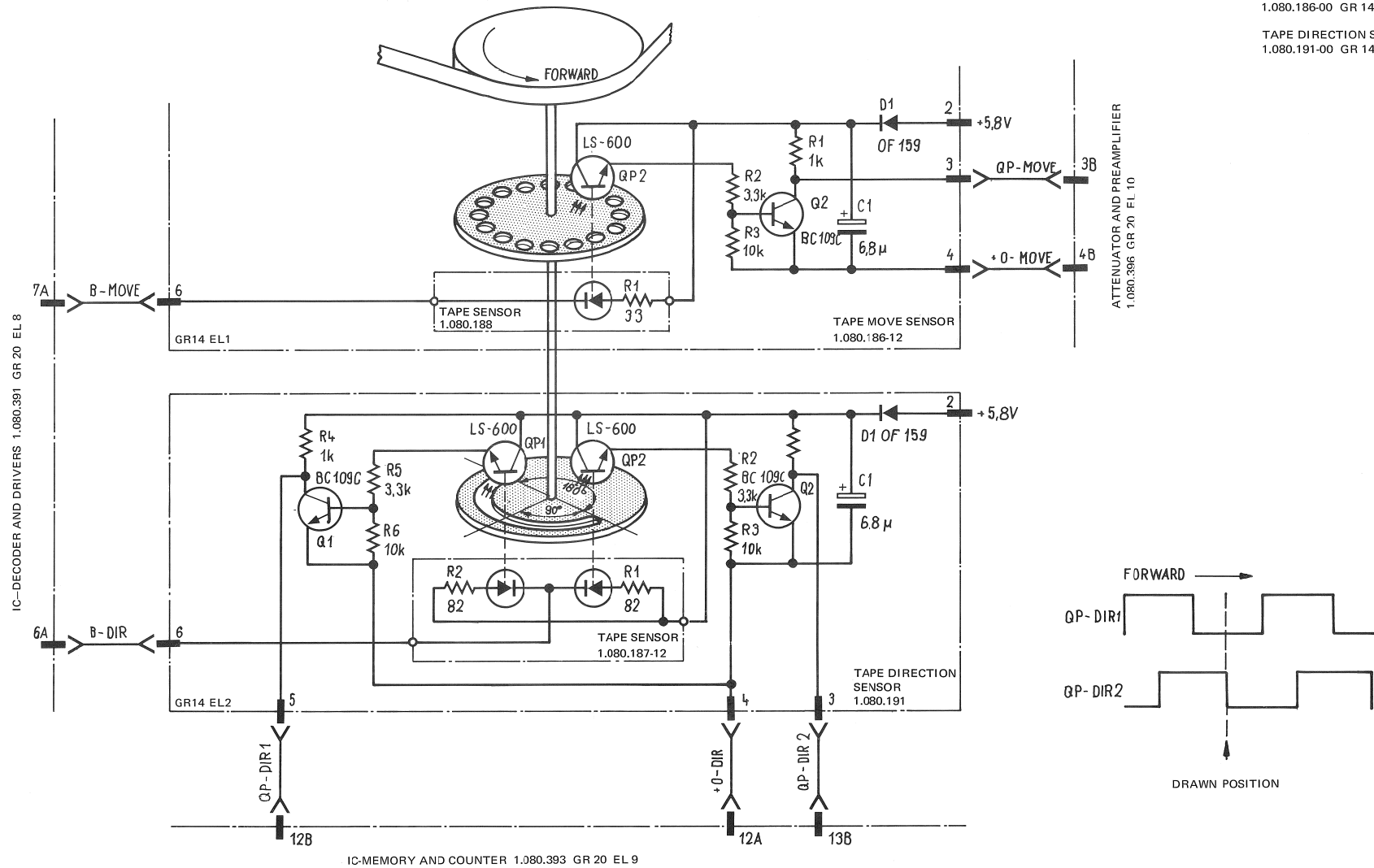

TAPE MOVE AND DIRECTION SENSOR UNIT 1.080.181

Pos.	Bauteil No.	Bezeichnung	Stk.	Bemerkung																									
① L2D 01	50.04.2103	LR-Diode, Infrarot T11.23	1																										
R 01	57.41.4330	R 33, 5%, .25 W, CSCH	1																										
<table border="1"> <tr> <td>Aenderungen</td> <td>① 18.12.72</td> <td>②</td> <td>④</td> <td>⑤</td> </tr> <tr> <td>STUDER</td> <td>Positionsliste</td> <td></td> <td>Erstellt: 18.9.72</td> <td>Bz</td> </tr> <tr> <td>REGENSDORF</td> <td>Bandabtaeter-Print</td> <td></td> <td>Gepfueh: <i>JK</i></td> <td></td> </tr> <tr> <td>ZURICH</td> <td></td> <td></td> <td>Blatt: 1</td> <td>Blätter: 1</td> </tr> <tr> <td>Kopie für:</td> <td>Ersetzt für:</td> <td></td> <td>Ersetzt durch:</td> <td>1.080.188.00</td> </tr> </table>					Aenderungen	① 18.12.72	②	④	⑤	STUDER	Positionsliste		Erstellt: 18.9.72	Bz	REGENSDORF	Bandabtaeter-Print		Gepfueh: <i>JK</i>		ZURICH			Blatt: 1	Blätter: 1	Kopie für:	Ersetzt für:		Ersetzt durch:	1.080.188.00
Aenderungen	① 18.12.72	②	④	⑤																									
STUDER	Positionsliste		Erstellt: 18.9.72	Bz																									
REGENSDORF	Bandabtaeter-Print		Gepfueh: <i>JK</i>																										
ZURICH			Blatt: 1	Blätter: 1																									
Kopie für:	Ersetzt für:		Ersetzt durch:	1.080.188.00																									

Pos.	Bauteil No.	Bezeichnung	Stk.	Bemerkung																										
C 01	59.10.5689	C 6,8 µ, 20%, 20 V _W , TA	1																											
D 01	50.04.0125	D 1N 4448	1	SI																										
Q 02	50.03.0407	Q NC 109 C	1	NPN																										
QP 02	50.03.0433	QP IS 600	1	NPNST																										
R 01	57.02.4102	R 1.0 K, 5%, .25 W, CMA	1																											
R 02	57.02.3332	R 3.3 K, 10%, .25 W	1																											
R 03	57.02.4103	R 10 K, 5%, .25 W	1																											
<table border="1"> <tr> <td>Aenderungen</td> <td>①</td> <td>②</td> <td>③</td> <td>④</td> <td>⑤</td> </tr> <tr> <td>STUDER</td> <td>Positionsliste</td> <td></td> <td>Erstellt: 18.9.72</td> <td>Bz</td> </tr> <tr> <td>REGENSDORF</td> <td>Bandbewegungsabtaeter-Print</td> <td></td> <td>Gepfueh: <i>JK</i></td> <td></td> </tr> <tr> <td>ZURICH</td> <td></td> <td></td> <td>Blatt: 1</td> <td>Blätter: 1</td> </tr> <tr> <td>Kopie für:</td> <td>Ersetzt für:</td> <td></td> <td>Ersetzt durch:</td> <td>1.080.186.00</td> </tr> </table>					Aenderungen	①	②	③	④	⑤	STUDER	Positionsliste		Erstellt: 18.9.72	Bz	REGENSDORF	Bandbewegungsabtaeter-Print		Gepfueh: <i>JK</i>		ZURICH			Blatt: 1	Blätter: 1	Kopie für:	Ersetzt für:		Ersetzt durch:	1.080.186.00
Aenderungen	①	②	③	④	⑤																									
STUDER	Positionsliste		Erstellt: 18.9.72	Bz																										
REGENSDORF	Bandbewegungsabtaeter-Print		Gepfueh: <i>JK</i>																											
ZURICH			Blatt: 1	Blätter: 1																										
Kopie für:	Ersetzt für:		Ersetzt durch:	1.080.186.00																										

Pos.	Bauteil No.	Bezeichnung	Stk.	Bemerkung																									
① L2D 01	50.04.2103	LR-Diode, Infrarot T11.23	1																										
L2D 02	50.04.2103	LR-Diode, Infrarot T11.23	1																										
R 01	57.41.4920	R B2, 5%, .25 W, CSCH	1																										
R 02	57.41.4920	R B2, 5%, .25 W, CSCH	1																										
<table border="1"> <tr> <td>Aenderungen</td> <td>① 18.12.72</td> <td>②</td> <td>④</td> <td>⑤</td> </tr> <tr> <td>STUDER</td> <td>Positionsliste</td> <td></td> <td>Erstellt: 18.9.72</td> <td>Bz</td> </tr> <tr> <td>REGENSDORF</td> <td>Bandabtaeter-Print</td> <td></td> <td>Gepfueh: <i>JK</i></td> <td></td> </tr> <tr> <td>ZURICH</td> <td></td> <td></td> <td>Blatt: 1</td> <td>Blätter: 1</td> </tr> <tr> <td>Kopie für:</td> <td>Ersetzt für:</td> <td></td> <td>Ersetzt durch:</td> <td>1.080.187.00</td> </tr> </table>					Aenderungen	① 18.12.72	②	④	⑤	STUDER	Positionsliste		Erstellt: 18.9.72	Bz	REGENSDORF	Bandabtaeter-Print		Gepfueh: <i>JK</i>		ZURICH			Blatt: 1	Blätter: 1	Kopie für:	Ersetzt für:		Ersetzt durch:	1.080.187.00
Aenderungen	① 18.12.72	②	④	⑤																									
STUDER	Positionsliste		Erstellt: 18.9.72	Bz																									
REGENSDORF	Bandabtaeter-Print		Gepfueh: <i>JK</i>																										
ZURICH			Blatt: 1	Blätter: 1																									
Kopie für:	Ersetzt für:		Ersetzt durch:	1.080.187.00																									

Pos.	Bauteil No.	Bezeichnung	Stk.	Bemerkung																										
C 01	59.10.5689	C 6,8 µ, 20%, 20 V _W , TA	1																											
D 01	50.04.0125	D 1N 4448	1	SI																										
Q 01	50.03.0407	Q NC 109 C	1	NPN																										
Q 02	50.03.0407	Q NC 109 C	1	NPN																										
QP 01	50.03.0433	QP IS 600	1	NPNST																										
QP 02	50.03.0433	QP IS 600	1	NPNST																										
R 01	57.02.4102	R 1.0 K, 5%, .25 W, CMA	1																											
R 02	57.02.3332	R 3.3 K, 10%, .25 W	1																											
R 03	57.02.4103	R 10 K, 5%, .25 W	1																											
R 04	57.02.4102	R 1.0 K, 5%, .25 W	1																											
R 05	57.02.3332	R 3.3 K, 10%, .25 W	1																											
R 06	57.02.4103	R 10 K, 5%, .25 W	1																											
<table border="1"> <tr> <td>Aenderungen</td> <td>①</td> <td>②</td> <td>③</td> <td>④</td> <td>⑤</td> </tr> <tr> <td>STUDER</td> <td>Positionsliste</td> <td></td> <td>Erstellt: 18.9.72</td> <td>Bz</td> </tr> <tr> <td>REGENSDORF</td> <td>Bandrichtungsabtaeter-Print</td> <td></td> <td>Gepfueh: <i>JK</i></td> <td></td> </tr> <tr> <td>ZURICH</td> <td></td> <td></td> <td>Blatt: 1</td> <td>Blätter: 1</td> </tr> <tr> <td>Kopie für:</td> <td>Ersetzt für:</td> <td></td> <td>Ersetzt durch:</td> <td>1.080.191.00</td> </tr> </table>					Aenderungen	①	②	③	④	⑤	STUDER	Positionsliste		Erstellt: 18.9.72	Bz	REGENSDORF	Bandrichtungsabtaeter-Print		Gepfueh: <i>JK</i>		ZURICH			Blatt: 1	Blätter: 1	Kopie für:	Ersetzt für:		Ersetzt durch:	1.080.191.00
Aenderungen	①	②	③	④	⑤																									
STUDER	Positionsliste		Erstellt: 18.9.72	Bz																										
REGENSDORF	Bandrichtungsabtaeter-Print		Gepfueh: <i>JK</i>																											
ZURICH			Blatt: 1	Blätter: 1																										
Kopie für:	Ersetzt für:		Ersetzt durch:	1.080.191.00																										

CONTACTOR 1.080.381 GR 20 EL 4

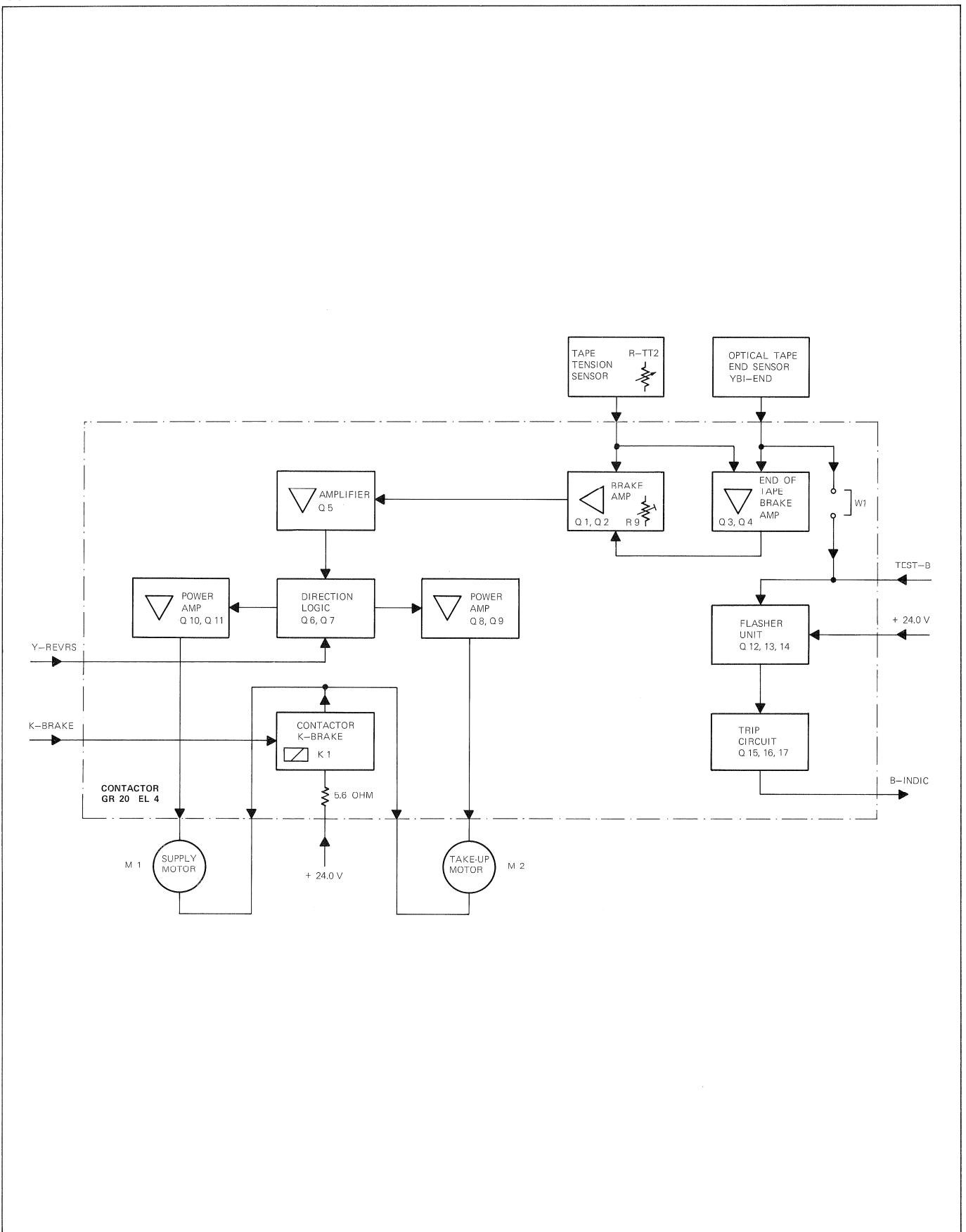

CONTACTOR 1.080.381 GR 20 EL 4

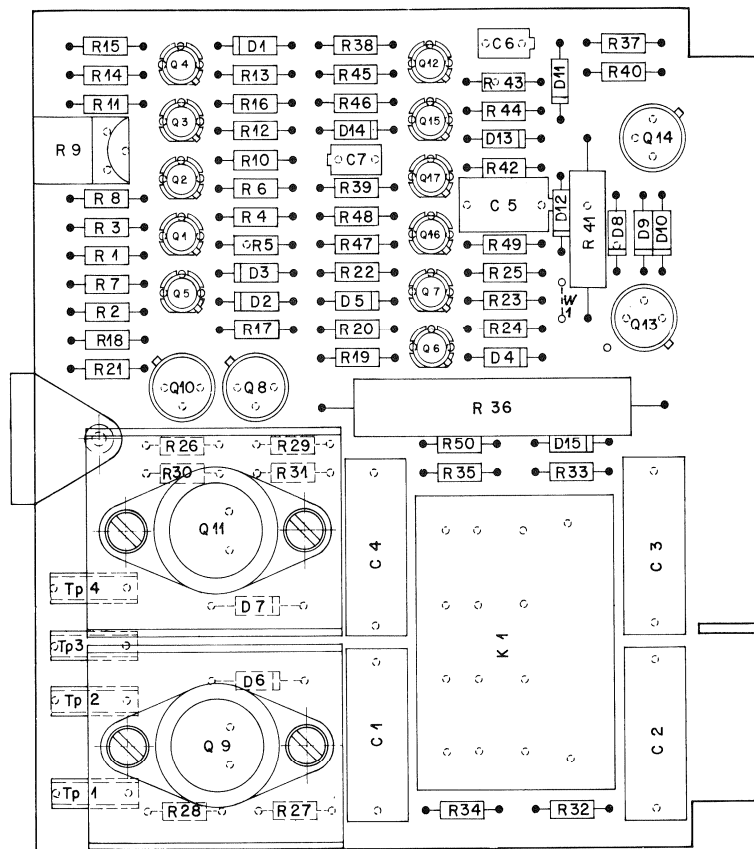

CONTACTOR 1.080.381 GR 20 EL 4

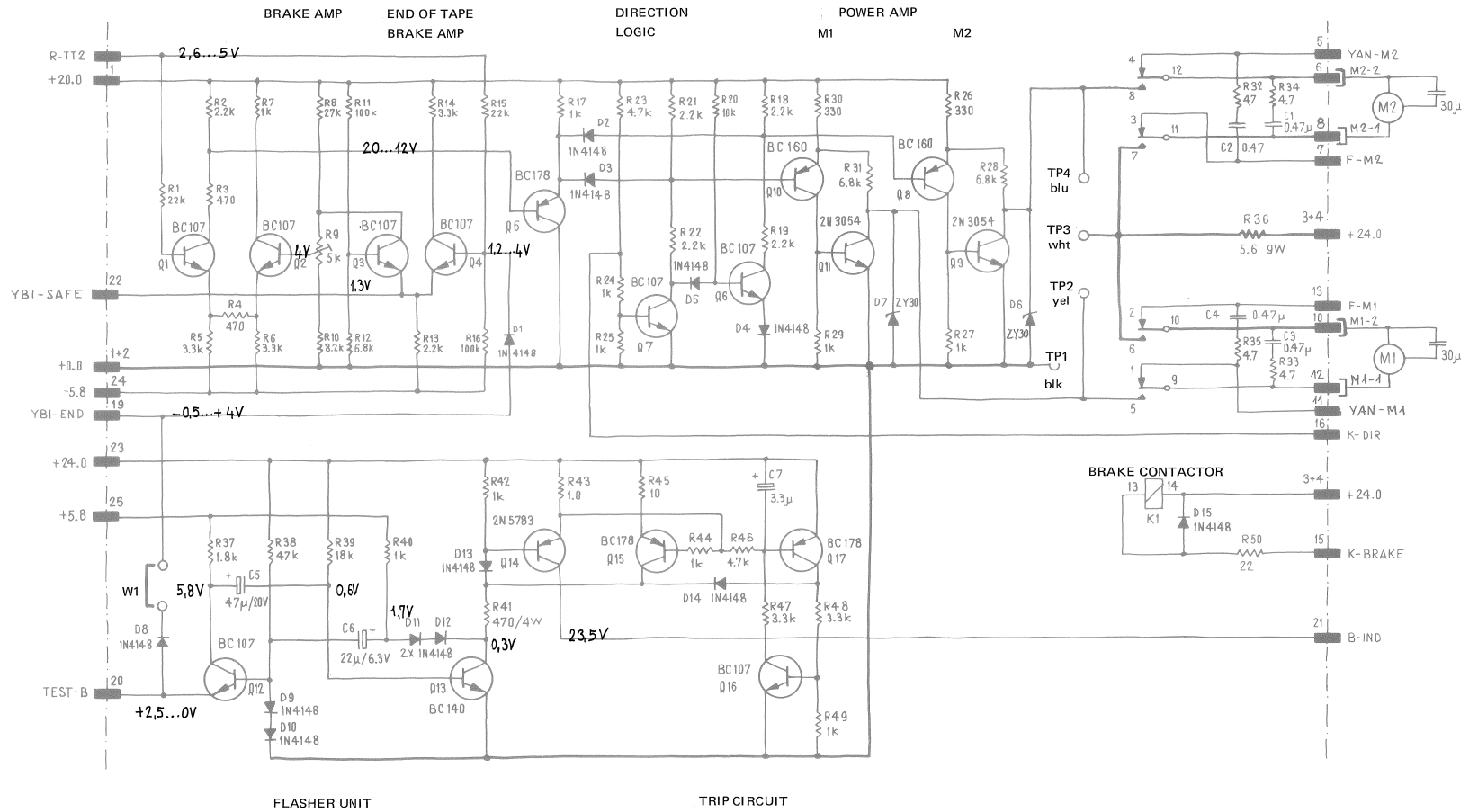

TP1 = 0.0 V
 TP2 } SEE BRAKE DIAGRAM BACKSIDE
 TP3 }
 TP4 }
 R9 = TT-BRAKE (max.)

TTL-SIGNALS SEE TABLE "LOGICAL OUTPUT SIGNALS"
 SECTION 4, CHAPTER 4.3.6

W1 = OFFEN : ANZEIGELAMPEN BLINKEN A) BEI UNTERBRUCH DER BANDBEWEGUNGS LED (TOTAL 3 STÜCK)
 B) BEI FEHLENDER -5,8 V SPEISUNG
 ZU : ANZEIGELAMPEN BLINKEN ZUSÄTZLICH, WENN DIE BAND-END-LICHTSCHRANKE ANSPRICHT (BAND AUSGEFÄDELT)

W1 = OPEN : INDICATION LAMPES FLASH A) WHEN THE TAPE MOVE SENSORS ARE INTERRUPTED (3 PIECES)
 B) WHEN -5.8 V SUPPLY IS MISSING.
 CLOSED : INDICATION LAMPES FLASH ADDITIONALLY WHEN THE TAPE END SENSOR RESPONSES (TAPE SLIPPED OUT)

CONTACTOR 1.080.381 GR 20 EL 4

Pos	Bauteil No.	Bezeichnung	Stk.	Bemerkung
C 01	59.99.0450	C .47 µF 150 V	MP	1
C 02	59.99.0450			1
C 03	59.99.0450			1
C 04	59.99.0450			1
C 05	59.10.5470	C 47 µF 20 V	TA	1
C 06	59.10.2220	C 22 µF 6.3 V	TA	1
C 07	59.10.5339	C 3.3 µF 20 V	TA	1
D 01	50.04.0102	D 1 N 914, 1 N 4143	SI	1
D 02	50.04.0102			1
D 03	50.04.0102			1
D 04	50.04.0102			1
D 05	50.04.0102			1
D 06	50.04.1506	D 30 V, 1.3 W,	Z	1
D 07	50.04.1506			1
D 08	50.04.0102	D 1 N 914, 1 N 4143	SI	1
D 09	50.04.0102			1
D 10	50.04.0102			1
D 11	50.04.0102			1
D 12	50.04.0102			1
D 13	50.04.0102			1
D 14	50.04.0102			1
D 15	50.04.0102			1
K 01	56.02.0108	K 24 V, 10 A, 4 U,		1
Q 01	50.03.0428	Q BC 107 A,	NFN	1
Q 02	50.03.0428			1
Q 03	50.03.0428			1
Q 04	50.03.0428			1
Q 05	50.03.0306	Q BC 178 B,	PNP	1
Q 06	50.03.0428	Q BC 107 A,	NFN	1
Q 07	50.03.0428	Q BC 107 A,	NFN	1
Q 08	50.03.0315	Q BC 160 - 16,	Siemens	1
Q 09	50.03.0480	Q 2 N 3054,	NFN	1 auf Kühlblech
Q 10	50.03.0315	Q BC 160 - 16,	Siemens	1
Q 11	50.03.0480	Q 2 N 3054,	NFN	1 auf Kühlblech
Q 12	50.03.0428	Q BC 107 A,	NFN	1
Q 13	50.03.0316	Q BC 160 - 16,	Siemens	1
Q 14	50.03.0306	Q 2 N 5783,	BSF 18	1
Q 15	50.03.0306	Q BC 178 B,	PNP	1
Q 16	50.03.0428	Q BC 107 A,	NFN	1
Q 17	50.03.0306	Q BC 178 B,	PNP	1
R 01	57.41.4223	R 22 K, 5%, .12 W, CSCH		1
R 02	57.41.4222	R 2.2 K,		1
R 03	57.41.4471	R 470		1
R 04	57.41.4471			1
R 05	57.41.4332	R 3.3 K,		1
R 06	57.41.4332	R 3.3 K,		1
R 07	57.41.4102	R 1 K,		1
R 08	57.41.4277	R 27 K, 5%, .12 W CSCH		1
R 09	58.01.3502	R 5 K, LTN, .5 W	P	1
R 10	57.41.4822	R 8.2 K, 5%, .12 W, CSCH		1
R 11	57.41.4104	R 100 K,		1
R 12	57.41.4682	R 6.8 K,		1
R 13	57.41.4222	R 2.2 K,		1
R 14	57.41.4332	R 3.3 K,		1
R 15	57.41.4223	R 22 K,		1
R 16	57.41.4104	R 100 K,		1
R 17	57.41.4102	R 1 K,		1
R 18	57.41.4222	R 2.2 K, 5%, .12 W, CSCH		1
R 19	57.41.4222			1
R 20	57.41.4103	R 10 K,		1
R 21	57.41.4222	R 2.2 K,		1
R 22	57.41.4222			1
R 23	57.41.4472	R 4.7 K,		1
R 24	57.41.4102	R 1 K,		1

Pos.	Bauteil No.	Bezeichnung	Stk.	Bemerkung
R 25	57.41.4102	R 1 K, 5%, .12 W, CSCH		1
R 26	57.02.5331	R 330,		1
R 27	57.02.5102	R 1 K, 10%, .25 W, CMA		1
R 28	57.02.5682	R 6.8 K,		1
R 29	57.02.5102	R 1 K,		1
R 30	57.02.5331	R 330,		1
R 31	57.02.5682	R 6.8 K,		1
R 32	57.02.5479	R 4.7,		1
R 33	57.02.5479			1
R 34	57.02.5479			1
R 35	57.02.5479			1
R 36	57.99.0194	R 5.6, 10%, 10 W, BR		1 erhöht montieren
R 37	57.41.4182	R 1.8 K, 5%, .12 W, CSCH		1
R 38	57.41.4473	R 47 K,		1
R 39	57.41.4183	R 18 K,		1
R 40	57.41.4102	R 1 K, .12 W,		1
R 41	57.36.4471	R 470, 5%, 4.2 W, BR		1
R 42	57.41.4102	R 1 K, .12 W, CSCH		1
R 43	57.41.4109	R 1,		1
R 44	57.41.4102	R 1 K,		1
R 45	57.41.4100	R 10,		1
R 46	57.41.4472	R 4.7 K,		1
R 47	57.41.4332	R 3.3 K,		1
R 48	57.41.4332			1
R 49	57.41.4102	R 1.0 K,		1
R 50	57.02.5329	R 22, 10%, .25 W, CMA		1
TP 01	54.01.0010	Buchse 2 mm,	sw	1
TP 02	54.01.0014	Buchse 2 mm,	sb	1
TP 03	54.01.0019	Buchse 2 mm,	sw	1
TP 04	54.01.0016	Buchse 2 mm,	bl	1

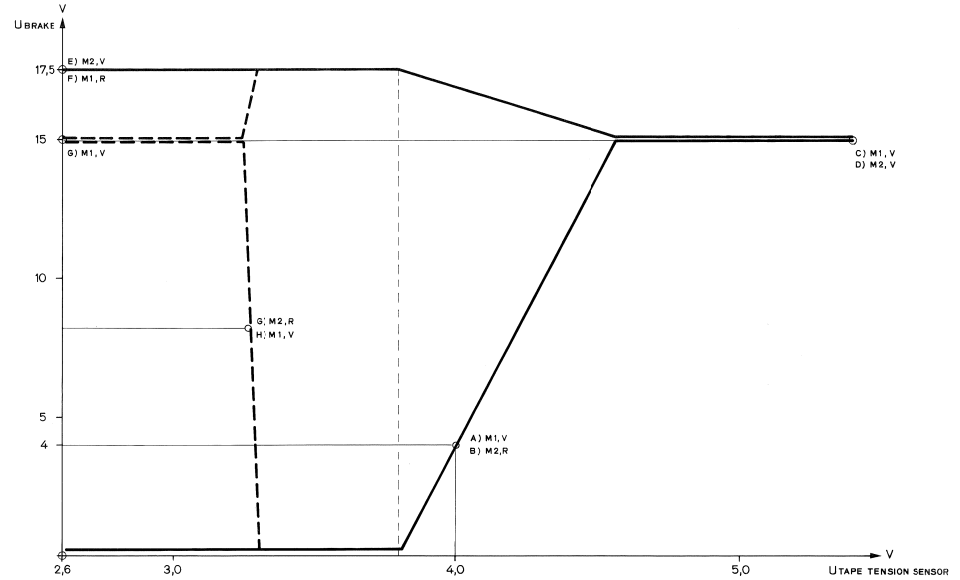

SPANNUNGSVERLAUF DER GLEICHSTROMBREMSE IN FUNKTION DER RECHTEN BANDZUGWAAGE:

- ROT : SPANNUNGSVERLAUF DES AUFWICKELNDEN MOTORS:
 - BEI BREMSUNG AUS DEM VORWÄRTSLAUF : SPANNUNG ZWISCHEN TP3 und TP2.
 - BEI BREMSUNG AUS DEM RÜCKWÄRTSLAUF : SPANNUNG ZWISCHEN TP3 und TP4.

- SCHWARZ : SPANNUNGSVERLAUF DES ABWICKELNDEN MOTORS:
 - BEI BREMSUNG AUS DEM VORWÄRTSLAUF : SPANNUNG ZWISCHEN TP3 und TP4.
 - BEI BREMSUNG AUS DEM RÜCKWÄRTSLAUF : SPANNUNG ZWISCHEN TP3 und TP2.

DIE ROT UND SCHWARZ GESTRICHELTEN KENNLINIEN ZEIGEN DEN VERLAUF DER BREMS-SPANNUNG BEI AUSFÄDELNDEM BAND.

VOLTAGE CURVE OF THE DIRECT-CURRENT BRAKE AS A FUNCTION OF THE RIGHT HAND TAPE TENSION SENSOR :

- RED : VOLTAGE CURVE OF THE WINDING UP MOTOR :
 - BRAKING AFTER FORWARD RUN : VOLTAGE BETWEEN TP3 and TP2.
 - BRAKING AFTER REVERSE RUN : VOLTAGE BETWEEN TP3 and TP4.

- BLACK : VOLTAGE CURVE OF THE WINDING OFF MOTOR :
 - BRAKING AFTER FORWARD RUN : VOLTAGE BETWEEN TP3 and TP4.
 - BRAKING AFTER REVERSE RUN : VOLTAGE BETWEEN TP3 and TP2.

RED AND BLACK CHARACTERISTICS (DASHED LINES) SHOW THE CURVATURE OF THE BRAKING VOLTAGE AFTER THE TAPE SLIPPED OUT.

SPOOLING MOTOR CONTROL 1/4" + 1/2" (7 1/2 - 15 ips) 1.080.383 GR20 EL5

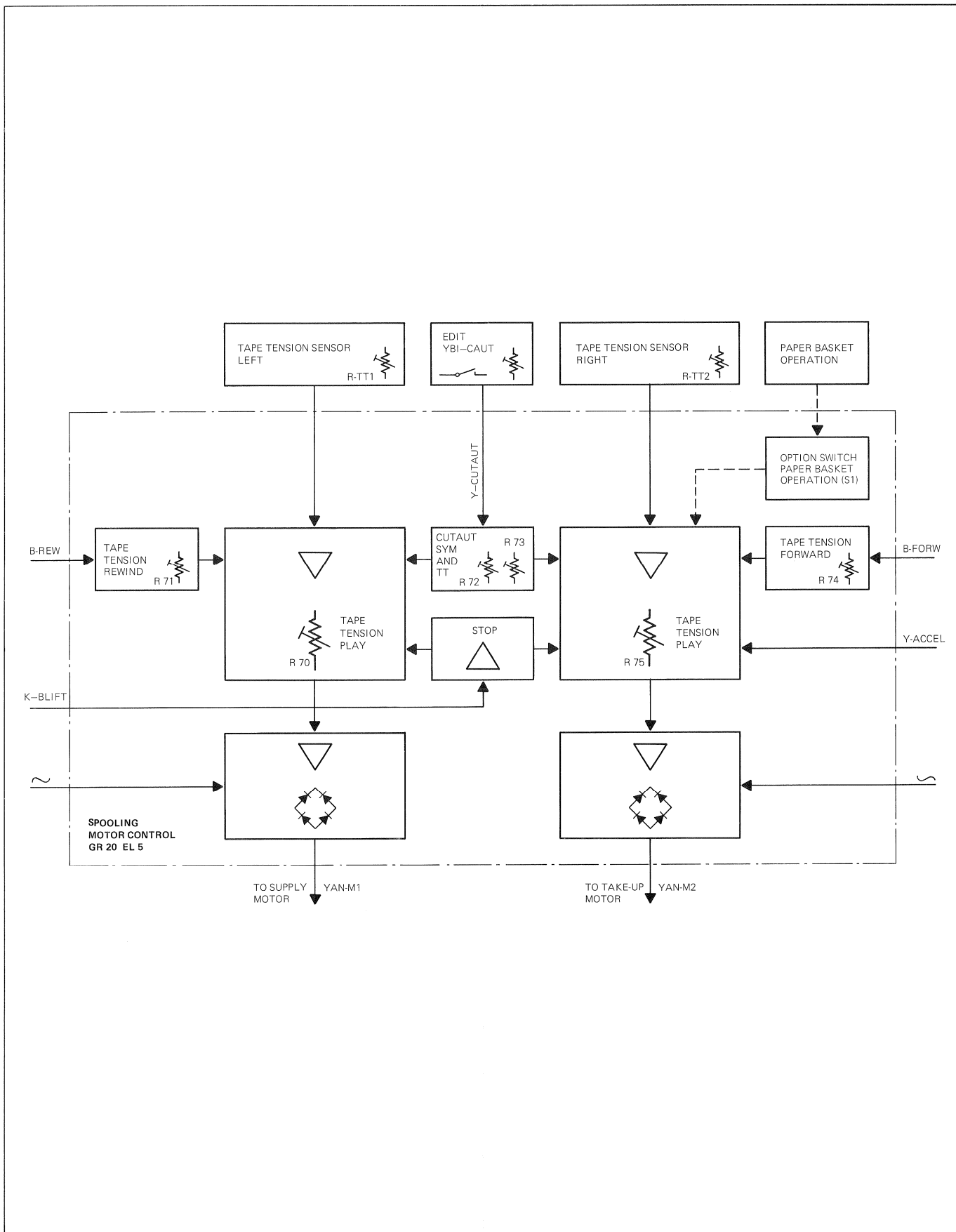

SPOOLING MOTOR CONTROL 1/4" + 1/2" (7 1/2 - 15 ips) 1.080.383 GR20 EL5

PLAY
SUPPLY MOTOR

REW

CUT
(EDIT)

CUT
(EDIT)

FORW

PLAY
TAKE-UP MOTOR

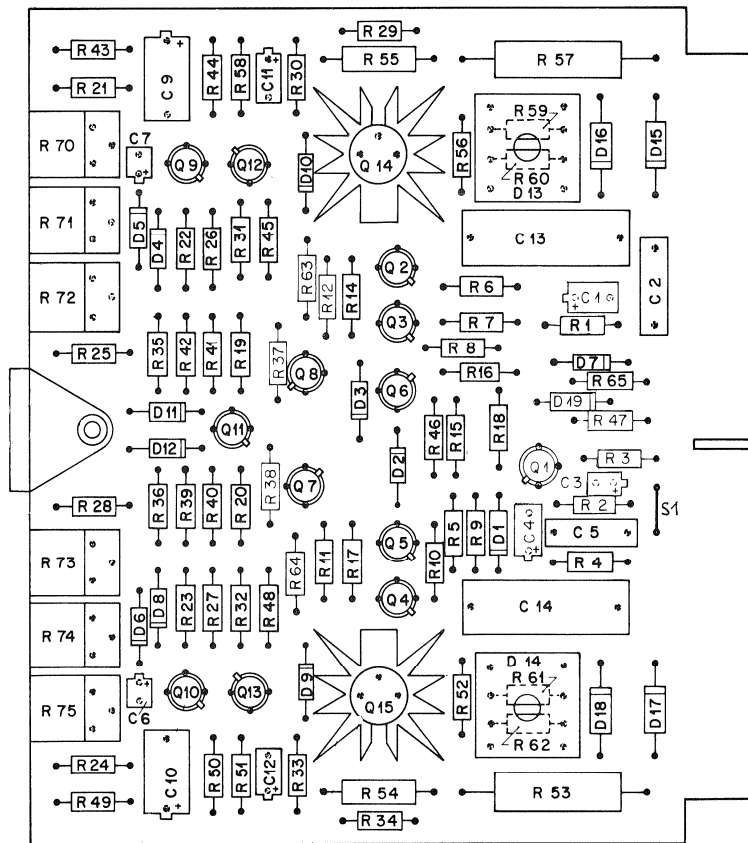

OPTION SWITCH S1: PAPER BASKET OPERATION

SPOOLING MOTOR CONTROL 1/4" + 1/2" (7 1/2 - 15 ips) 1.080.383 GR20 EL5

VALID FOR PC BOARD 1.080.383-13

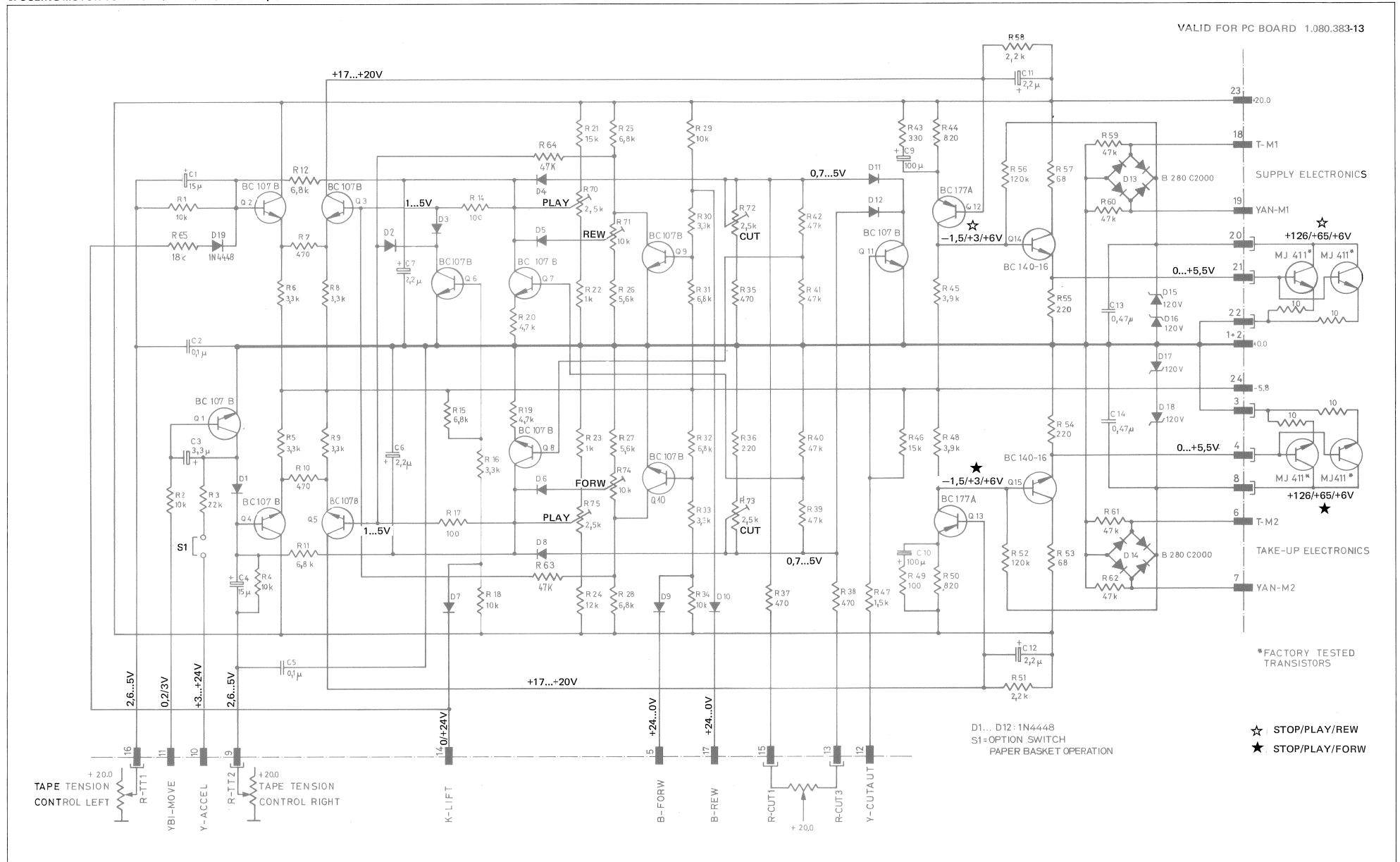

SPOOLING MOTOR CONTROL 1/4" + 1/2" (7 1/2 - 15 ips) 1.080.383 GR20 EL5

Pos.	Bauftel No.	Bezeichnung	Stk.	Bemerkung
C 1	59.10.5150	C 15 U, 20%, 10 V, TA	1	
C 2	59.05.2104	C 3.1 U, 10%, 100 V, PC	1	
C 3	59.10.4339	C 3.3 U, 20%, 16 V, PA	1	
C 4	59.10.5150	C 15 U, 20%, 10 V, PA	1	
C 5	59.05.2104	C 3.1 U, 10%, 100 V, PC	1	
C 6	59.10.5229	C 2.2 U, 20%, 20 V, PA	1	
C 7	59.10.5229	C 2.2 U, 20%, 20 V, PA	1	
C 9	59.10.3101	C 100 U, 20%, 10 V, TA	1	
C 10	59.10.3101	C 100 U, 20%, 10 V, TA	1	
C 11	59.10.7229	C 2.2 U, 20%, 35 V, PA	1	
C 12	59.10.7229	C 2.2 U, 20%, 35 V, PA	1	
C 13	59.99.0450	C 0.47 U, 10%, 150 V, MP	1	
C 14	59.99.0450	C 0.47 U, 10%, 150 V, MP	1	
D 19	50.04.0125	D 1W 4448	BT	1
D 21	50.04.0125	D	BT	1
D 22	50.04.0125	D	BT	1
D 23	50.04.0125	D	BT	1
D 24	50.04.0125	D	BT	1
D 25	50.04.0125	D	BT	1
D 26	50.04.0125	D	BT	1
D 27	50.04.0125	D	BT	1
D 28	50.04.0125	D	BT	1
D 29	50.04.0125	D	BT	1
D 30	50.04.0125	D	BT	1
D 31	50.04.0125	D	BT	1
D 32	50.04.0125	D	BT	1
D 33	70.01.0226	Gleichrichter 2A, 280V		1
D 34	70.01.0226	Gleichrichter 2A, 280V		1
D 15	50.04.1505	D 120 V, 5%, 1.3 W Z		1
D 16	50.04.1505	D 120 V, 5%, 1.3 W Z		1
D 17	50.04.1505	D 120 V, 5%, 1.3 W Z		1
D 18	50.04.1505	D 120 V, 5%, 1.3 W Z		1

Änderungen ① 4, 9, 73, 74 ② 10, 12, 73, 74 ③ ④ ⑤

STUDER	Positionliste	Erstellt: 1.12.71	Blz
REGENSDORF	Wickelmotor-Steuerung 1/4 + 1/2 "	Geprüft: 3.42.74	AK
ZÜRICH		Blatt: 1	Blätter: 4

Kopie für: Ersetzt für: Ersetzt durch: 1.080.383

Pos.	Bauftel No.	Bezeichnung	Stk.	Bemerkung
Q 01	50.03.0408	Q BC 107 B	NPN	1
Q 02	50.03.0408	Q BC 107 B	NPN	1
Q 03	50.03.0408	Q BC 107 B	NPN	1
Q 04	50.03.0408	Q BC 107 B	NPN	1
Q 05	50.03.0408	Q BC 107 B	NPN	1
Q 06	50.03.0408	Q BC 107 B	NPN	1
Q 07	50.03.0408	Q BC 107 B	NPN	1
Q 08	50.03.0408	Q BC 107 B	NPN	1
Q 09	50.03.0408	Q BC 107 B	NPN	1
Q 10	50.03.0408	Q BC 107 B	NPN	1
Q 11	50.03.0408	Q BC 107 B	NPN	1
Q 12	50.03.0307	Q BC 177 A	PNP	1
Q 13	50.03.0307	Q BC 177 A	PNP	1
Q 14	50.03.0316	Q BC 140-16	NPN	1
Q 15	50.03.0316	Q BC 140-16	NPN	1
R 01	57.41.4103	R 10 K, 5%, .12 W, CSCH	1	
R 02	57.41.4103	R 10 K, 5%, .12 W, CSCH	1	
R 03	57.41.4473	R 47 K, 5%, .12 W, CSCH	1	
R 04	57.41.4103	R 10 K, 5%, .12 W, CSCH	1	
R 05	57.41.4332	R 3.3 K, 5%, .12 W, CSCH	1	
R 06	57.41.4332	R 3.3 K, 5%, .12 W, CSCH	1	
R 07	57.41.4473	R 47 K, 5%, .12 W, CSCH	1	
R 08	57.41.4332	R 3.3 K, 5%, .12 W, CSCH	1	
R 09	57.41.4332	R 3.3 K, 5%, .12 W, CSCH	1	
R 10	57.41.4473	R 47 K, 5%, .12 W, CSCH	1	
R 11	57.41.4682	R 6.8 K, 5%, .12 W, CSCH	1	
R 12	57.41.4682	R 6.8 K, 5%, .12 W, CSCH	1	
R 14	57.41.4101	R 10 K, 5%, .12 W, CSCH	1	①
R 15	57.41.4682	R 6.8 K, 5%, .12 W, CSCH	1	
R 16	57.41.4332	R 3.3 K, 5%, .12 W, CSCH	1	
R 17	57.41.4101	R 10 K, 5%, .12 W, CSCH	1	①

Änderungen ① 10, 12, 73, 74 ② ③ ④ ⑤

STUDER	Positionliste	Erstellt: 1.12.71	Blz
REGENSDORF	Wickelmotor-Steuerung 1/4 + 1/2 "	Geprüft: 3.42.74	AK
ZÜRICH		Blatt: 1	Blätter: 4

Kopie für: Ersetzt für: Ersetzt durch: 1.080.383

Pos.	Bauftel No.	Bezeichnung	Stk.	Bemerkung
R 18	57.41.4103	R 10 K, 5%, .12 W, CSCH	1	
R 19	57.41.4472	R 4.7 K, 5%, .12 W, CSCH	1	
R 20	57.41.4472	R 4.7 K, 5%, .12 W, CSCH	1	
R 21	57.41.4153	R 15 K, 5%, .12 W, CSCH	1	
R 22	57.41.4102	R 1.0 K, 5%, .12 W, CSCH	1	
R 23	57.41.4102	R 1.0 K, 5%, .12 W, CSCH	1	
R 24	57.41.4123	R 12 K, 5%, .12 W, CSCH	1	
R 25	57.41.4682	R 6.8 K, 5%, .12 W, CSCH	1	
R 26	57.41.4682	R 6.8 K, 5%, .12 W, CSCH	1	
R 27	57.41.4682	R 6.8 K, 5%, .12 W, CSCH	1	
R 28	57.41.4682	R 6.8 K, 5%, .12 W, CSCH	1	
R 29	57.41.4103	R 10 K, 5%, .12 W, CSCH	1	
R 30	57.41.4332	R 3.3 K, 5%, .12 W, CSCH	1	
R 31	57.41.4682	R 6.8 K, 5%, .12 W, CSCH	1	
R 32	57.41.4682	R 6.8 K, 5%, .12 W, CSCH	1	
R 33	57.41.4332	R 3.3 K, 5%, .12 W, CSCH	1	
R 34	57.41.4103	R 10 K, 5%, .12 W, CSCH	1	
R 35	57.41.4471	R 47 K, 5%, .12 W, CSCH	1	
R 36	57.41.4321	R 22 K, 5%, .12 W, CSCH	1	
R 37	57.41.4473	R 47 K, 5%, .12 W, CSCH	1	
R 38	57.41.4473	R 47 K, 5%, .12 W, CSCH	1	
R 39	57.41.4473	R 47 K, 5%, .12 W, CSCH	1	
R 40	57.41.4473	R 47 K, 5%, .12 W, CSCH	1	
R 41	57.41.4473	R 47 K, 5%, .12 W, CSCH	1	
R 42	57.41.4473	R 47 K, 5%, .12 W, CSCH	1	
R 43	57.41.4131	R 33 K, 5%, .12 W, CSCH	1	
R 44	57.41.4921	R 82 K, 5%, .12 W, CSCH	1	
R 45	57.41.4192	R 3.9 K, 5%, .12 W, CSCH	1	
R 46	57.41.4153	R 15 K, 5%, .12 W, CSCH	1	
R 47	57.41.4152	R 1.5 K, 5%, .12 W, CSCH	1	
R 48	57.41.4192	R 3.9 K, 5%, .12 W, CSCH	1	
R 49	57.41.4101	R 10 K, 5%, .12 W, CSCH	1	
R 50	57.41.4921	R 82 K, 5%, .12 W, CSCH	1	
R 51	57.41.4122	R 2.2 K, 5%, .12 W, CSCH	1	
R 52	57.41.4124	R 120 K, 5%, .12 W, CSCH	1	

Änderungen ① ② ③ ④ ⑤

STUDER	Positionliste	Erstellt: 1.12.71	Blz
REGENSDORF	Wickelmotor-Steuerung 1/4 + 1/2 "	Geprüft: 3.42.74	AK
ZÜRICH		Blatt: 3	Blätter: 4

Kopie für: Ersetzt für: Ersetzt durch: 1.080.383

Pos.	Bauftel No.	Bezeichnung	Stk.	Bemerkung
R 53	57.56.4580	R 68 K, 5%, 4.2 W, DR	1	
R 54	57.42.4221	R 220 K, 5%, 33 W, CSCH	1	
R 55	57.42.4221	R 220 K, 5%, 33 W, CSCH	1	
R 56	57.41.4124	R 120 K, 5%, .12 W, CSCH	1	
R 57	57.56.4580	R 68 K, 5%, 4.2 W, DR	1	
R 58	57.41.4222	R 2.2 K, 5%, .12 W, CSCH	1	
R 59	57.41.4473	R 47 K, 5%, .12 W, CSCH	1	
R 60	57.41.4473	R 47 K, 5%, .12 W, CSCH	1	
R 61	57.41.4473	R 47 K, 5%, .12 W, CSCH	1	
R 62	57.41.4473	R 47 K, 5%, .12 W, CSCH	1	
R 63	57.41.4473	R 47 K, 5%, .12 W, CSCH	1	
R 64	57.41.4473	R 47 K, 5%, .12 W, CSCH	1	
R 65	57.41.4183	R 18 K, 5%, .12 W, CSCH	1	

Änderungen ① 14, 3, 72, 74 ② 4, 9, 73, 74 ③ 10, 12, 73, 74 ④ ⑤

STUDER	Positionliste	Erstellt: 1.12.71	Blz
REGENSDORF	Wickelmotor-Steuerung 1/4 + 1/2 "	Geprüft: 3.42.74	AK
ZÜRICH		Blatt: 4	Blätter: 4

Kopie für: Ersetzt für: Ersetzt durch: 1.080.383

Änderungen ① 14, 3, 72, 74 ② 4, 9, 73, 74 ③ 10, 12, 73, 74 ④ ⑤

STUDER	Positionliste	Erstellt: 1.12.71	Blz
REGENSDORF	Wickelmotor-Steuerung 1/4 + 1/2 "	Geprüft: 3.42.74	AK
ZÜRICH		Blatt: 4	Blätter: 4

Kopie für: Ersetzt für: Ersetzt durch: 1.080.383

SPOOLING MOTOR CONTROL 1/4" + 1/2" (15 - 30 ips) 1.080.385-81 GR20 EL5

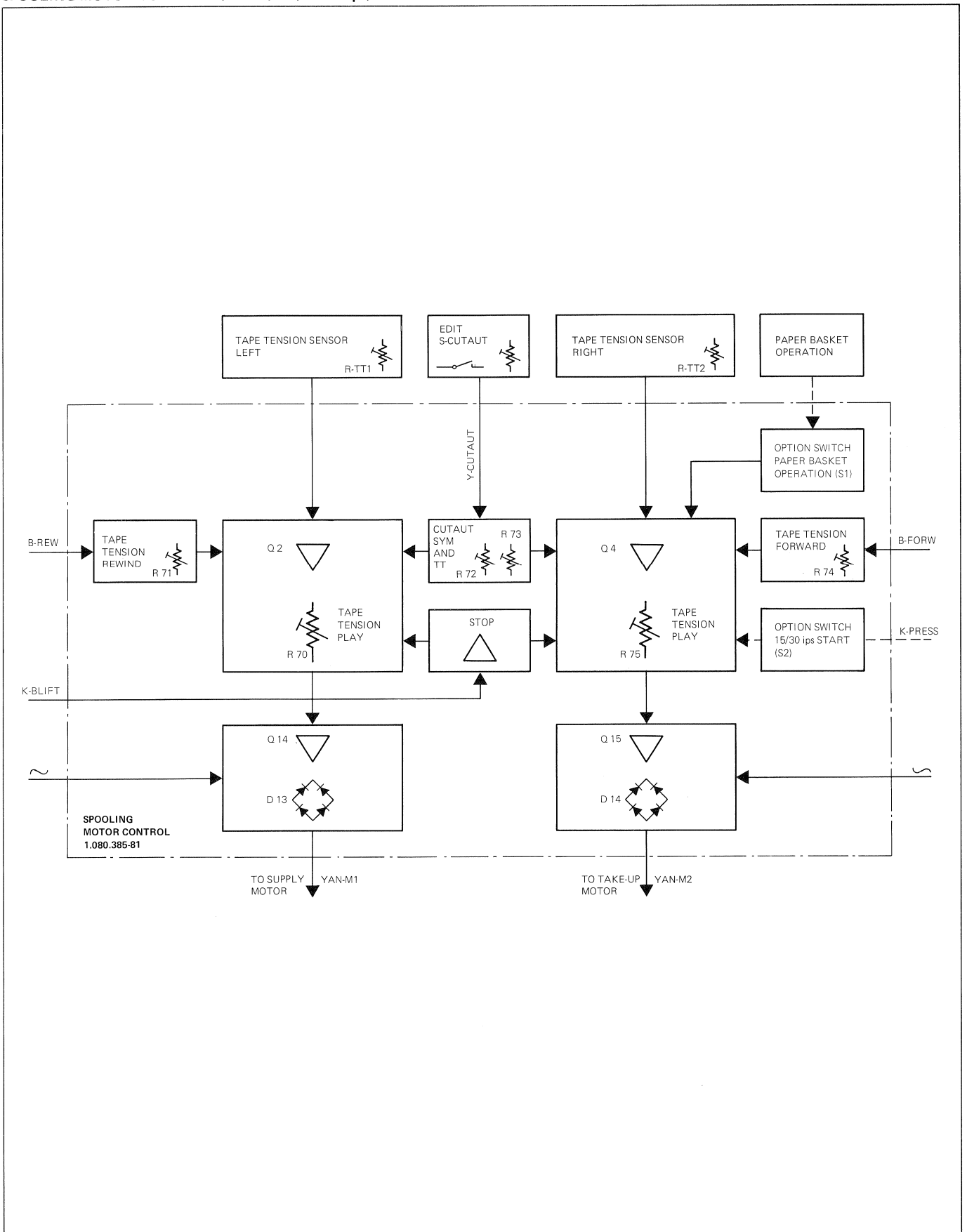

SPOOLING MOTOR CONTROL 1/4" + 1/2" (15 - 30 ips) 1.080.385-81 GR20 EL5

PLAY
SUPPLY MOTOR

REW

CUT
(EDIT)

CUT
(EDIT)

FORW

PLAY
TAKE-UP MOTOR

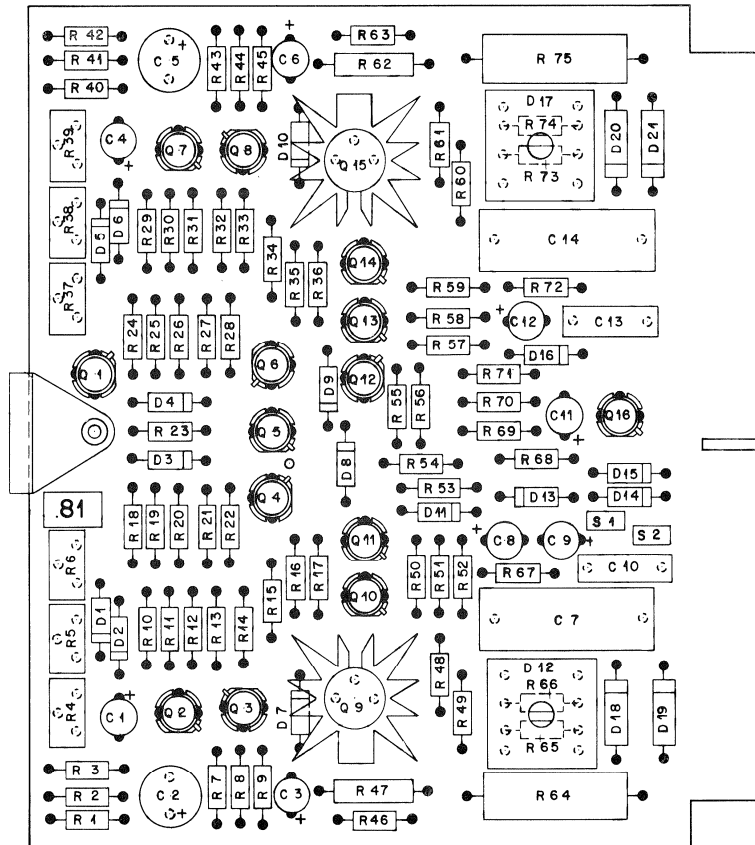

OPTION SWITCH S1: PAPER BASKET OPERATION
OPTION SWITCH S2: 15/30 ips START

SPOOLING MOTOR CONTROL 1/4" + 1/2" (15 - 30 ips) 1.080.385-81 GR20 EL5

VALID FOR PC BOARD 1.080.385-12

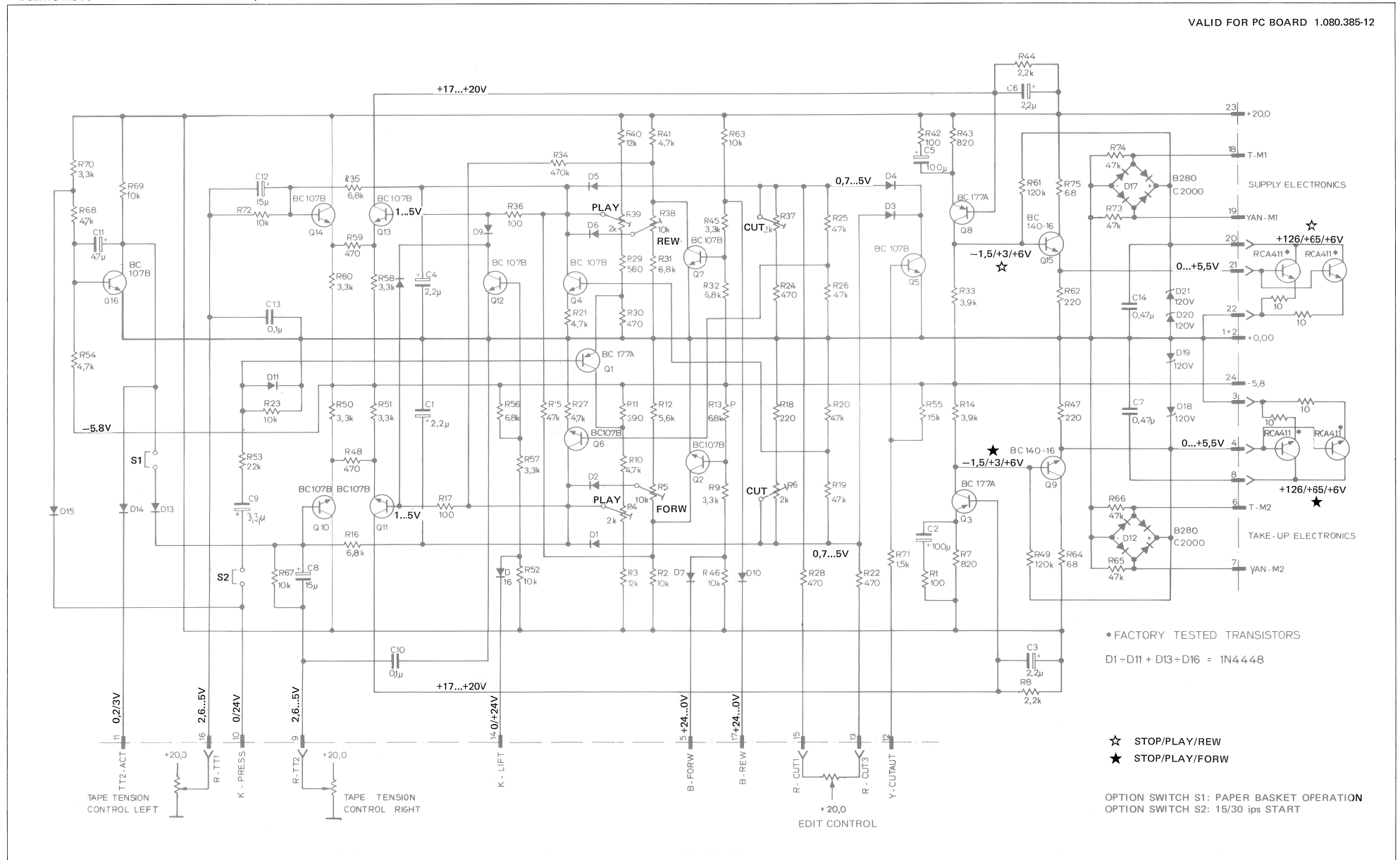

* FACTORY TESTED TRANSISTORS

D1=D11 + D13+D16 = 1N4448

- ☆ STOP/PLAY/REW
- ★ STOP/PLAY/FORW

OPTION SWITCH S1: PAPER BASKET OPERATION
 OPTION SWITCH S2: 15/30 ips START

SPOOLING MOTOR CONTROL 1/4" + 1/2" (15 - 30 ips) 1.080.385-81 GR20 EL5

INDX POS NO	PART NO	VALUE	SPECIFICATIONS/EQUIVALENT	MFR
C 01	58.36.4829	2.2 μ F	25V 20% TH	
C 02	58.36.4829	100 μ F	10V -10% EL	
C 03	58.36.4829	2.2 μ F	25V 20% TH	
C 04	58.36.4829	2.2 μ F		
C 05	58.36.4829	100 μ F	10V -10% EL	
C 06	58.36.4829	2.2 μ F	25V 20% TH	
C 07	58.36.4829	2.2 μ F	150V 10% NP	
C 08	58.30.5450	15 μ F	20V 20% TH	
C 09	58.30.5450	5.8 μ F	35V 20% TH	
C 10	58.05.2404	0.1 μ F	100V 10% MFC	
C 11	58.36.4473	47 μ F	25V 20% TH	
C 12	58.30.5450	15 μ F	20V 20% TH	
C 13	58.05.2404	0.1 μ F	100V 10% MFC	
C 14	58.33.0450	247 μ F	150V 10% NP	
D 01	50.04.0425	1N4448	75V 100mA	
D 02				
D 03				
D 04				
D 05				
D 06				
D 07				
D 08				
D 09				
D 10				
D 11	50.04.0425			
D 12	70.04.0226	2A	280V Rectifier	
D 13	50.04.0425	1N4448	75V 100mA	
D 14	50.04.0425			

INDX	DATE	NAME
①		
②		
③		
④		
⑤		
⑥	16.8.79	Sh

TH = Tantalum
EL = Electrolytic

STUDER	Spooling Motor Control	1.080.385-81	PAGE 1 OF 5
--------	------------------------	--------------	-------------

INDX POS NO	PART NO	VALUE	SPECIFICATIONS/EQUIVALENT	MFR
D 15	50.04.0425	1N4448	75V 100mA	
D 16	50.04.0425	1N4448		
D 17	70.04.0226	2A	280V Rectifier	
D 18	50.04.4505	120V	Z-Diode 5% 1.3W	
D 19				
D 20				
D 21	50.04.1605			
Q 01	50.03.0307	8C177A	PNP	
Q 02	50.03.0408	8C107B	NPN	
Q 03	50.03.0307	8C177A	PNP	
Q 04	50.03.0408	8C107B	NPN	
Q 05				
Q 06				
Q 07	50.03.0408			
Q 08	50.03.0307	8C177A	PNP	
Q 09	50.03.0316	8C107A	NPN	
Q 10	50.03.0408	8C107B	NPN	
Q 11				
Q 12				
Q 13				
Q 14	50.03.0408			
Q 15	50.03.0316	8C107A	NPN	
Q 16	50.03.0408	8C107B	NPN	
R 01	57.44.4101	100 Ω	5% 0.25W CF	
R 02	57.44.4103	10 k		
R 03	57.44.4123	12 k		

INDX	DATE	NAME
①		
②		
③		
④		
⑤		
⑥	16.8.79	Sh

CF = Carbon Film

STUDER	Spooling Motor Control	1.080.385-81	PAGE 2 OF 5
--------	------------------------	--------------	-------------

INDX POS NO	PART NO	VALUE	SPECIFICATIONS/EQUIVALENT	MFR
R 04	58.04.7202	2 k	10% 0.5W Lin. C	
R 05	58.04.7403	10 k		
R 06	57.04.7202	2 k		
R 07	57.44.4824	820 Ω	5% 0.25W CF	
R 08	57.44.4227	2.2 k		
R 09	57.44.4332	3.3 k		
R 10	57.44.4123	4.7 k		
R 11	57.44.4123	390 Ω		
R 12	57.44.4562	5.6 k		
R 13	57.44.4682	6.8 k		
R 14	57.44.4332	3.3 k		
R 15	57.44.4473	4.7 k		
R 16	57.44.4682	6.8 k		
R 17	57.44.4101	100 Ω		
R 18	57.44.4224	220 Ω		
R 19	57.44.4473	4.7 k		
R 20	57.44.4473	4.7 k		
R 21	57.44.4472	4.7 k		
R 22	57.44.4103	10 k		
R 23	57.44.4103	470 Ω		
R 24	57.44.4471	470 Ω		
R 25	57.44.4473	4.7 k		
R 26	57.44.4473	4.7 k		
R 27	57.44.4472	4.7 k		
R 28	57.44.4471	470 Ω		
R 29	57.44.4561	560 Ω		
R 30	57.44.4471	470 Ω		
R 31	57.44.4682	6.8 k		
R 32	57.44.4682	6.8 k		
R 33	57.44.4332	3.3 k		

INDX	DATE	NAME
①		
②		
③		
④		
⑤		
⑥	16.8.79	Sh

C = Carbon
CF = Carbon Film

STUDER	Spooling Motor Control	1.080.385-81	PAGE 3 OF 5
--------	------------------------	--------------	-------------

INDX POS NO	PART NO	VALUE	SPECIFICATIONS/EQUIVALENT	MFR
R 34	57.44.4474	470 k		
R 35	57.44.4682	6.8 k		
R 36	57.44.4101	100 Ω		
R 37	58.04.7202	2 k	10% 0.5W Lin. C	
R 38	58.04.7403	10 k		
R 39	58.04.7202	2 k		
R 40	57.44.4123	10 k	5% 0.25W CF	
R 41	57.44.4472	4.7 k		
R 42	57.44.4101	100 Ω		
R 43	57.44.4824	820 Ω		
R 44	57.44.4222	2.2 k		
R 45	57.44.4332	3.3 k		
R 46	57.44.4103	10 k		
R 47	57.42.4221	220 Ω	5% 0.25W CF	
R 48	57.44.4471	470 Ω	5% 0.25W CF	
R 49	57.44.4424	120 k		
R 50	57.44.4332	3.3 k		
R 51	57.44.4332	3.3 k		
R 52	57.44.4103	10 k		
R 53	57.44.4223	2.2 k		
R 54	57.44.4472	4.7 k		
R 55	57.44.4153	15 k		
R 56	57.44.4682	6.8 k		
R 57	57.44.4332	3.3 k		
R 58	57.44.4332	3.3 k		
R 59	57.44.4471	470 Ω		
R 60	57.44.4332	3.3 k		
R 61	57.44.4124	120 k		
R 62	57.42.4221	220 Ω	5% 0.25W CF	
R 63	57.44.4103	10 k	5% 0.25W CF	

INDX	DATE	NAME
①		
②		
③		
④		
⑤		
⑥	16.8.79	Sh

C = Carbon
CF = Carbon Film

STUDER	Spooling Motor Control	1.080.385-81	PAGE 4 OF 5
--------	------------------------	--------------	-------------

INDX POS NO	PART NO	VALUE	SPECIFICATIONS/EQUIVALENT	MFR
R 64	57.56.4680	68 Ω	5% 4W WW	
R 65	57.44.4473	4.7 k	5% 0.25W CF	
R 66	57.44.4473	4.7 k		
R 67	57.44.4473	4.7 k		
R 68	57.44.4472	4.7 k		
R 69	57.44.4473	4.7 k		
R 70	57.44.4332	3.3 k		
R 71	57.44.4152	15 k		
R 72	57.44.4473	4.7 k		
R 73	57.44.4473	4.7 k		
R 74	57.44.4473	4.7 k		
R 75	57.56.4680	68 Ω	5% 4W WW	

INDX	DATE	NAME
①		
②		
③		
④		
⑤		
⑥	16.8.79	Sh

WW = Wirewound
CF = Carbon Film

STUDER	Spooling Motor Control	1.080.385-81	PAGE 5 OF 5
--------	------------------------	--------------	-------------

CAPSTAN SERVO WITH VARIABLE SPEED CONTROL 1.080.372/374/377 GR 20 EL 6

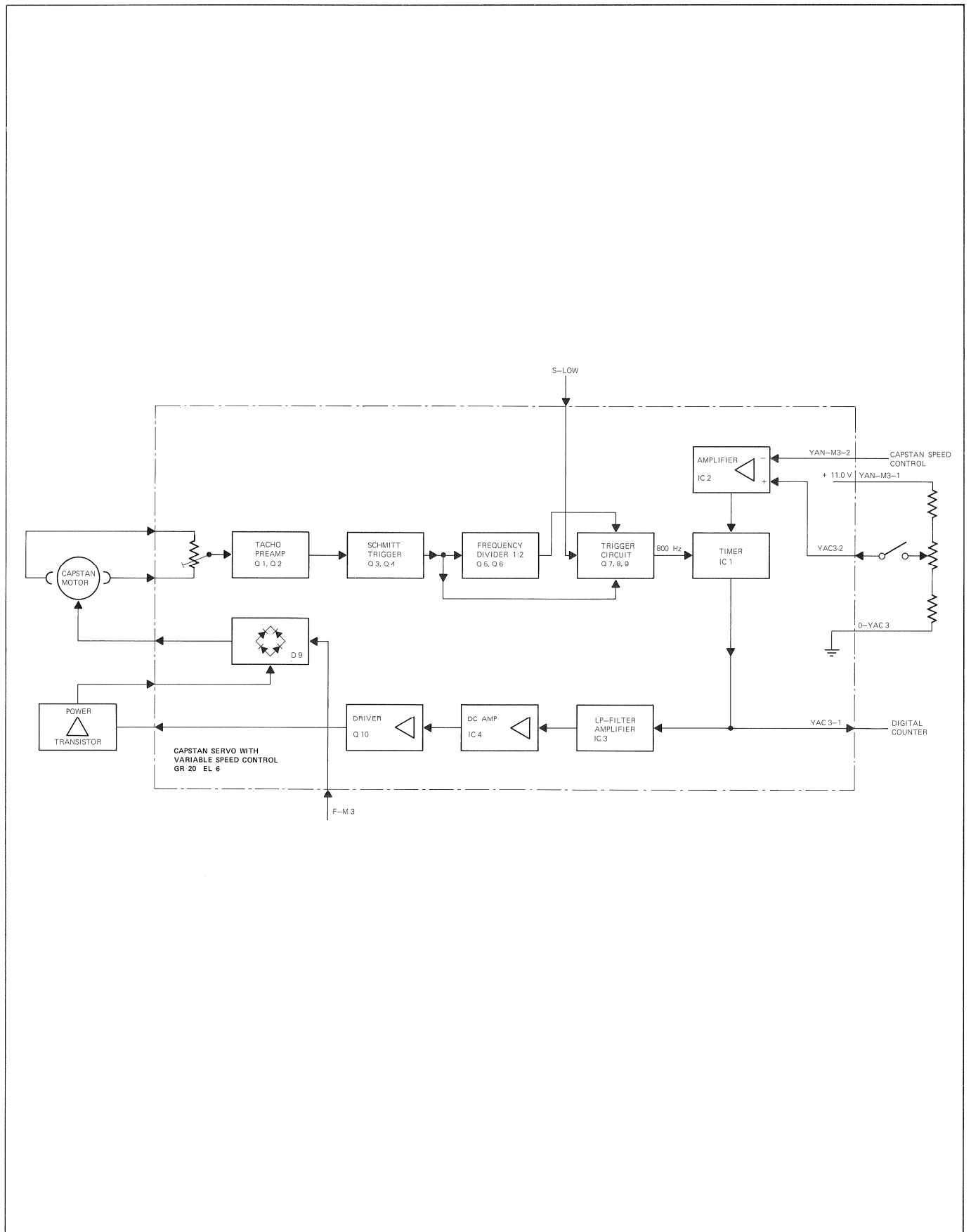

CAPSTAN SERVO WITH VARIABLE SPEED CONTROL 1.080.372/374/377 GR 20 EL 6

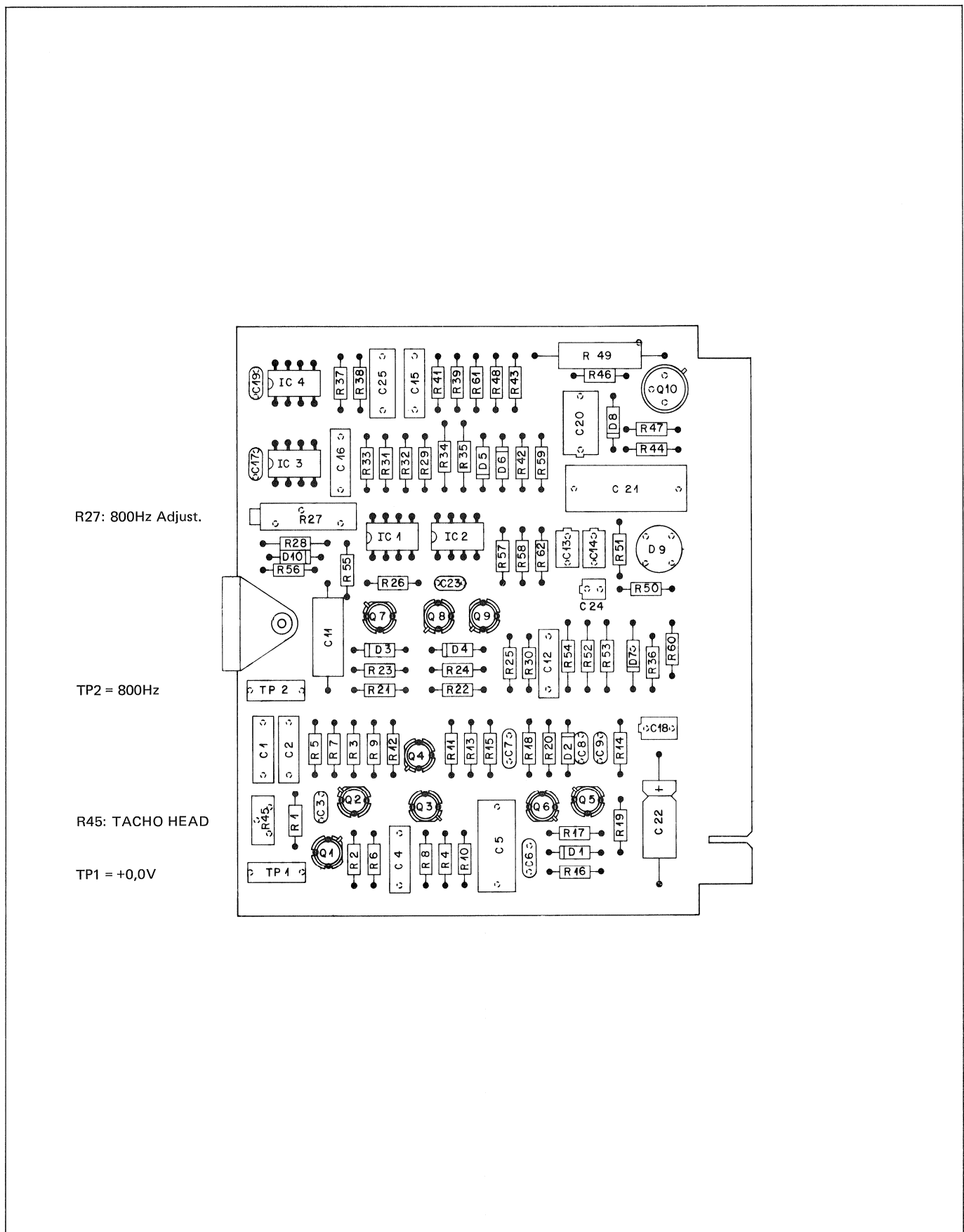

CAPSTAN SERVO WITH VARIABLE SPEED CONTROL 1.080.372/374/377 GR 20 EL 6

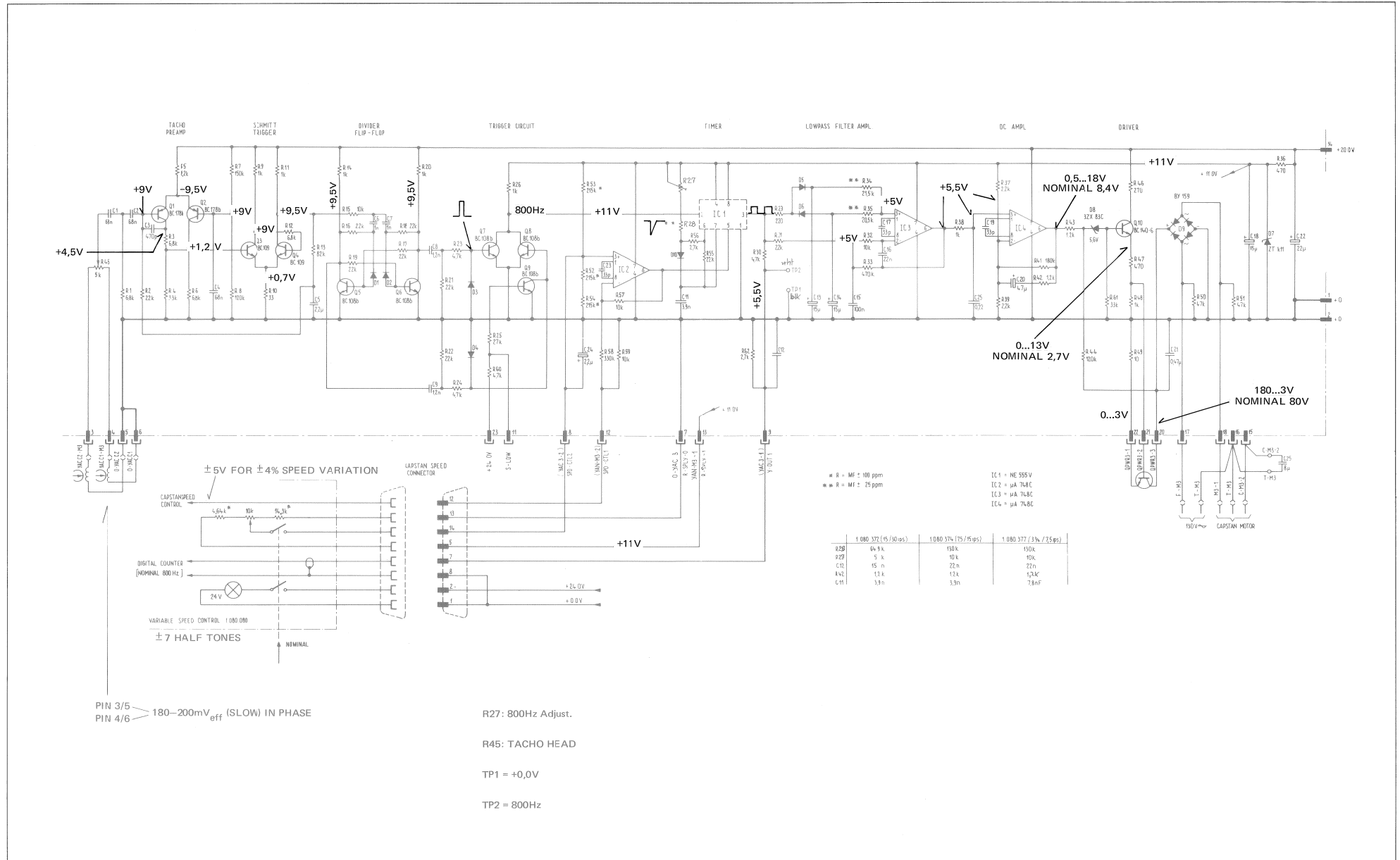

CAPSTAN SERVO WITH VARIABLE SPEED CONTROL 1.080.372/374/377 GR 20 EL 6

Pos	Bauteil No.	Bezeichnung	Stk.	Bemerkung
C 01	59.31.6683	68 N, $\pm 10\%$, 100V, PFTF	1	
C 01	59.31.6683			
C 03	59.32.1471	473 P, $\pm 10\%$, 500V, KER	1	
C 04	59.31.6683	68 N, $\pm 10\%$, 100V, PFTF	1	
C 05	59.05.1225	2,2 U, $\pm 10\%$, 63V, MFC	1	
C 06	59.32.1102	1 N, $\pm 10\%$, 500V, KER	1	
C 07	59.32.1102			
C 08	59.32.1122	1,2 N, 10%, 500V, KBR	1	
C 09	59.32.1122			
(3) C 10	59.29.0140	2,15 N, $\pm 1\%$, 300V, G1ammer	1	
(3) C 11	59.12.7192	3,3 N, 1%, 63V, PS	1	
(3) C 12	59.31.6223	23 N, 10%, 100V, PFTF	1	
C 13	59.10.5150	15 U, 20%, 20V, TA	1	
C 14	59.10.5150			
C 15	59.31.9104	0,1 U, 10%, 160V, MPFPTF	1	
C 16	59.31.6223	22 N, 10%, 100V, MPFPTF	1	
C 17	59.32.1330	33 P, 10%, 500V, KER	1	
C 18	59.10.5150	15 U, 20%, 20V, TA	1	
C 19	59.32.1330	33 P, 10%, 500V, KER	1	
C 20	59.10.5470	47 U, 20%, 20V, TA	1	
C 21	59.99.0450	0,47 U, 10%, 150V, MP	1	
C 22	59.25.5220	22 U, 10%, 40V, BL	1	
C 23	59.32.1330	33 P, 10%, 500V, KER	1	
C 24	59.10.5229	2,2 U, 20%, 20V, TA	1	
C 25	59.31.6224	0,22U, 10%, 100V, MPFPTF	1	
(3) C 26	59.32.5492	4,2 N, $\pm 10\%$, 50V, KER	1	
D 01	50.04.0125	D 1N 4448	SI	1
D 02	50.04.0125			
D 03	50.04.0125			
D 04	50.04.0125			
D 05	50.04.0125			
D 06	50.04.0125			
D 07	50.04.0107	1 x 942,	Z	1
D 08	50.04.1108	5,5 V, 5%, 0,4W, Z		1
D 09	70.01.0223	BY 159 / 400	SI	1

Aenderungen: 16.8.75(12) 8.3.76(7) 6.1.77(4) 12.9.77(5)		Erstellt: 14.1.1975	cp
STUDER Positionenliste		Erstellt: 14.1.1975	cp
REGENSDORF ZÜRICH Capstan-Print bestückt		Geprüft: 14.4.75	AG
Blatt: 1		Blätter: 4	
Kopie für: Ersetzt durch:		1.080.374	

Pos	Bauteil No.	Bezeichnung	Stk.	Bemerkung
(3) D 12	50.04.0125	D 1N 4448	SI	1
IC 01	50.05.0156	MC 1455 P.1,	TIMER	1
IC 02	50.05.0144	uA 748 TC	LIN	1
IC 03	50.05.0144			1
IC 04	50.05.0144			1
Q 01	50.03.0306	BC 178 B,		1
Q 02	50.03.0306	BC 178 B,		1
Q 03	50.03.0407	BC 109 C,		1
Q 04	50.03.0407			1
Q 05	50.03.0409	BC 108 B,		1
Q 06	50.03.0409			1
Q 07	50.03.0409			1
Q 08	50.03.0409			1
Q 09	50.03.0409			1
Q 10	50.03.0418	BC 140-6		1
R 01	57.41.4682	6,8 K, 5%, 0,25W, CSCH		1
R 02	57.41.4223	22 K,		1
R 03	57.41.4682	6,8 K,		1
R 04	57.41.4332	3,3 K,		1
R 05	57.41.4682	6,8 K,		1
R 06	57.41.4682	6,8 K,		1
R 07	57.41.4154	150 K,		1
R 08	57.41.4124	120 K,		1
R 09	57.41.4102	1 K, 5%, 0,25W, CSCH		1
R 10	57.41.4330	33,		1
R 11	57.41.4102	1 K,		1
R 12	57.41.4682	6,8 K,		1
R 13	57.41.4682	6,8 K,		1
R 14	57.41.4102	1 K,		1
R 15	57.41.4103	10 K,		1
R 16	57.41.4223	22 K,		1
R 17	57.41.4223	22 K,		1

Aenderungen: 16.8.75(12) 8.3.76(7) 6.1.77(4) 12.9.77(5)		Erstellt: 14.1.1975	cp
STUDER Positionenliste		Erstellt: 14.1.1975	cp
REGENSDORF ZÜRICH Capstan-Print bestückt		Geprüft: 14.4.75	AG
Blatt: 2		Blätter: 4	
Kopie für: Ersetzt durch:		1.080.374	

Pos	Bauteil No.	Bezeichnung	Stk.	Bemerkung
R 18	57.41.4223	22 K, 5%, 0,25W, CSCH		1
R 19	57.41.4223	22 K,		1
R 20	57.41.4102	1 K,		1
R 21	57.41.4223	22 K,		1
R 22	57.41.4223	22 K,		1
R 23	57.41.4272	4,7 K,		1
R 24	57.41.4272	4,7 K,		1
R 25	57.41.4273	27 K,		1
R 26	57.41.4102	1 K,		1
(3) R 27	58.11.7103	10 K, 10%, 0,5W, PERSMPT		1
R 28	57.99.0177	130 K, 1%, 25 PFM, MP		1
R 29	57.41.4321	220 5%, 0,25W, CSCH		1
(3) R 30	57.41.4472	4,7 K, 10%, 0,25W, CSCH		1
R 31	57.41.4223	22 K,		1
R 32	57.41.4103	10 K,		1
R 33	57.41.4474	470 K,		1
(4) R 34	57.39.2152	21,5 K, 1%, D 2,5	MP	1
(3) R 35	57.39.2052	20,5 K		1
R 36	57.41.4471	470, 5%, 0,25W, CSCH		1
R 37	57.41.4222	2,2 K,		1
(3) R 38	57.41.4472	4,7 K, 5%		1
R 39	57.41.4222	2,2 K,		1
R 41	57.41.4184	180 K,		1
R 42	57.41.4122	1,2 K,		1
R 43	57.41.4122	1,2 K,		1
R 44	57.41.4124	120 K,		1
(3) R 45	58.01.7502	5 K, 10%, 0,5W, FPG		1
R 46	57.41.4271	270, 5%, 0,25W, CSCH		1
R 47	57.41.4471	470,		1
R 48	57.41.4102	1 K,		1
R 49	57.56.4100	10, 5%, 5,5W	DR	1
R 50	57.41.4473	47 K, 5%, 0,25W	CSCH	1
R 51	57.41.4473	47 K,		1
R 52	57.39.2153	215 K, 1%, D 2,5	MP	1

Aenderungen: 16.8.75(12) 8.3.76(7) 6.1.77(4) 12.9.77(5)		Erstellt: 14.1.1975	cp
STUDER Positionenliste		Erstellt: 14.1.1975	cp
REGENSDORF ZÜRICH Capstan-Print bestückt		Geprüft: 14.4.75	AG
Blatt: 3		Blätter: 4	
Kopie für: Ersetzt durch:		1.080.374	

Pos	Bauteil No.	Bezeichnung	Stk.	Bemerkung
R 53	57.39.2153	215 K, 1%, D 2,5, MP		1
R 54	57.39.2153	215 K,		1
(3) R 55	57.41.4223	22 K, 5%, 0,25W, CSCH		1
(3) R 56	57.41.4272	2,7 K,		1
R 57	57.41.4103	10 K, 5%, 0,25W, CSCH		1
R 58	57.41.4136	330 K,		1
R 59	57.41.4103	10 K,		1
R 60	57.41.4472	4,7 K,		1
(3) R 61	57.41.4333	33 K,		1
R 62	57.41.4272	2,7 K,		1
TP 01	54.01.0610	Twatbuchse 2mm sw		1
TP 02	54.01.0619	sw		1

Aenderungen: 16.8.75(12) 8.3.76(7) 6.1.77(4) 12.9.77(5)		Erstellt: 14.1.1975	cp
STUDER Positionenliste		Erstellt: 14.1.1975	cp
REGENSDORF ZÜRICH Capstan-Print bestückt		Geprüft: 14.4.75	AG
Blatt: 4		Blätter: 4	
Kopie für: Ersetzt durch:		1.080.374	

IC DECODER AND DRIVERS 1.080.391 GR 20 EL 8

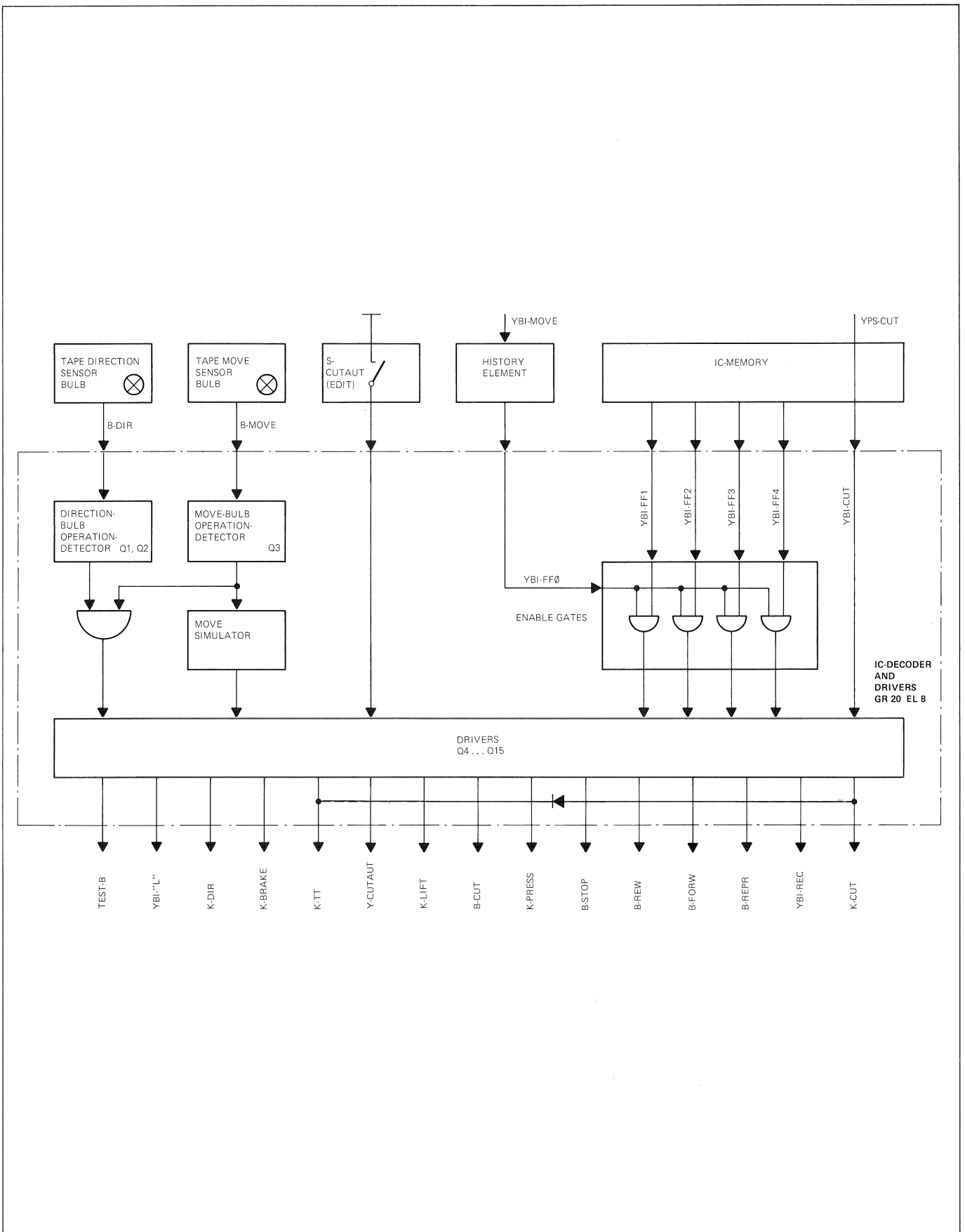

IC DECODER AND DRIVERS 1.080.391 GR 20 EL 8

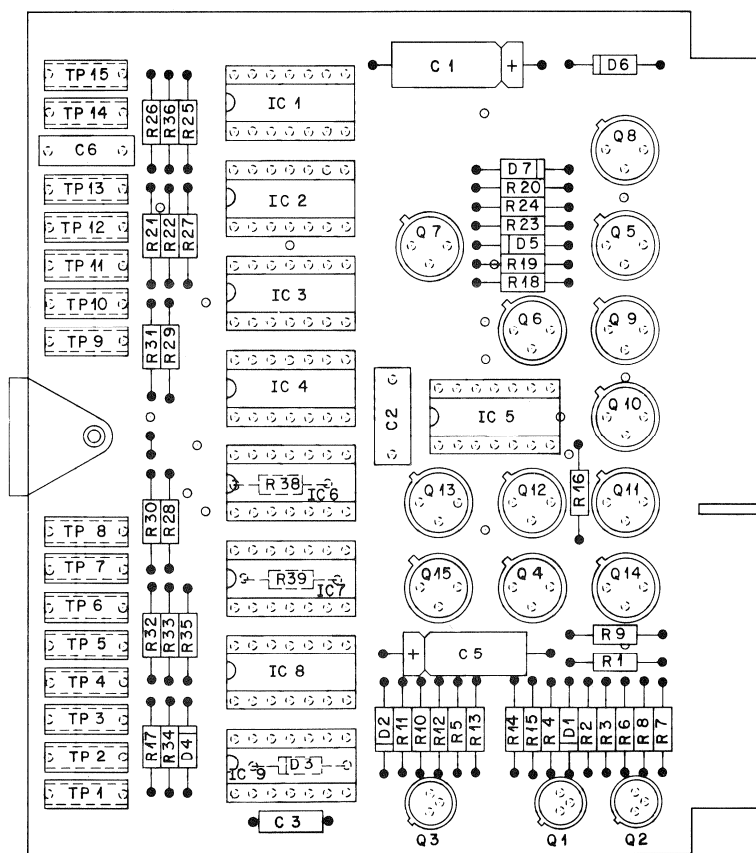

IC DECODER AND DRIVERS 1.080.391 GR 20 EL 8

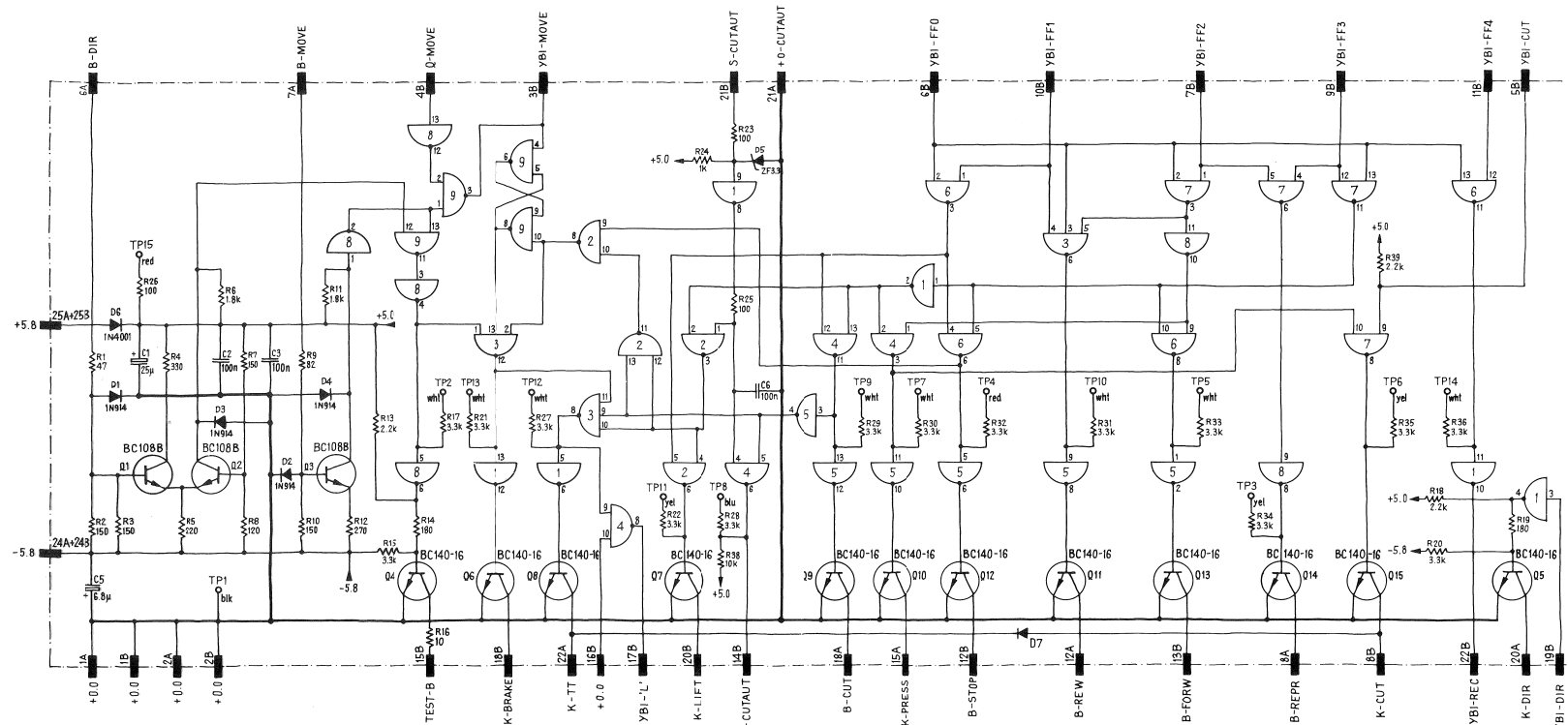

- TP1 = + 0.0
- TP2 = TEST-B
- TP3 = B-REPR (TTL)
- TP4 = B-STOP (TTL)
- TP5 = B-FORW (TTL)
- TP6 = K-CUT (TTL)
- TP7 = K-PRESS (TTL)
- TP8 = Y-CUTAUT (TTL)
- TP9 = B-CUT (TTL)
- TP10 = B-REW (TTL)
- TP11 = K-LIFT (TTL)
- TP12 = K-TT (TTL)
- TP13 = K-BRAKE (TTL)
- TP14 = YBI-REC (TTL)
- TP15 = + 5.0 V

TTL-SIGNALS SEE TABLE "LOGICAL OUTPUT SIGNALS"
SECTION 4, CHAPTER 4.3.6

IC DECODER AND DRIVERS 1.080.391 GR 20 EL 8

Pos.	Bauteil No.	Bezeichnung	Stk.	Bemerkung
C 1	59.25.5270	21 u., +50 %, 40 V=	EL	1
C 2	59.05.2104	100 n., 10 %, 100 V,	MPC	1
C 3	59.99.0997	100 n., +80 %, 25 V,	KBR	1
C 5	59.25.5220	22 u., +50 %, 40 V=	EL	1
C 5	59.05.2104	100 n., 10 %, 100 V,	MPC	1
D 1	50.04.0125	D 1 N 4448	SI	1
D 2	50.04.0125			1
D 3	50.04.0125			1
D 4	50.04.0125			1
D 5	50.04.1107	3.1 V, 5 %, .4 W,	Z	1
D 4	50.04.0122	1 N 4001		1
D 7	50.04.0122	1 N 4001		1
Q 1	50.03.0409	IK 108 B,		1
Q 2	50.03.0409	IK 108 B,		1
Q 3	50.03.0409	IK 108 B,		1
Q 4	50.03.0316	IK 140 / 16		1
Q 5	50.03.0316	IK 140 / 16		1
Q 6	50.03.0316	IK 140 / 16		1
Q 7	50.03.0316	IK 140 / 16		1
Q 8	50.03.0316	IK 140 / 16		1
Q 9	50.03.0316	IK 140 / 16		1
Q 10	50.03.0316	IK 140 / 16		1
Q 11	50.03.0316	IK 140 / 16		1
Q 12	50.03.0316	IK 140 / 16		1
Q 13	50.03.0316	IK 140 / 16		1
Q 14	50.03.0316	IK 140 / 16		1
Q 15	50.03.0316	IK 140 / 16		1

Aenderungen		(1) 1.2.7.73	(2) 10.7.74	(3)	(4)	(5)
STUDER	Positionsliste	Erstellt: 4.5.73 wa		Gepf: 7.5.73 RJK		
REGENSDORF	IC DECODER-PRINT	RESTUCKT	Blatt 1 Blätter 3			
ZÜRICH	Kopie für		Ersetzt durch: 1.080.391.00			

Pos.	Bauteil No.	Bezeichnung	Stk.	Bemerkung
R 1	57.31.3470	47 , 2 %, .25 W,	MP	1
R 2	57.31.3151	150 ,		
R 3	57.31.3151	150 ,		
R 4	57.02.5331	3.3 , 10 %, .25 W,	CMA	1 AB
R 5	57.02.5221	2.2 ,		1 AB
R 6	57.02.5182	1.3 k,		1 AB
R 7	57.31.3151	150 , 2 %, .25 W,	MP	1
R 8	57.31.3121	120 ,		1
R 9	57.02.5820	82 , 10 %, .25 W,	CMA	1 AB
R 10	57.02.5151	150 ,		1 AB
R 11	57.02.5182	1.3 k,		1 AB
R 12	57.02.5271	270 ,		1 AB
R 13	57.02.5242	2.5 k,		1 AB
R 14	57.02.5181	180 ,		1 AB
R 15	57.02.5332	3.3 k,		1 AB
R 16	57.02.5100	100 ,		1 AB
R 17	57.02.5332	3.3 k,		1 AB
R 18	57.02.5222	2.2 k,		1 AB
R 19	57.02.5181	180 ,		1 AB
R 20	57.02.5332	3.3 k,		1 AB
R 21	57.02.5332	3.3 k,		1 AB
R 22	57.02.5332	3.3 k,		1 AB
R 23	57.02.5101	100 ,		1 AB
R 24	57.02.5102	1.0 k,		1 AB
R 25	57.02.5101	100 ,		1 AB
R 26	57.02.5101	100 ,		1 AB
R 27	57.02.5332	3.3 k,		1 AB
R 28	57.02.5332	3.3 k,		1 AB
R 29	57.02.5332	3.3 k,		1 AB
R 30	57.02.5332	3.3 k,		1 AB
R 31	57.02.5332	3.3 k,		1 AB
R 32	57.02.5332	3.3 k,		1 AB
R 33	57.02.5332	3.3 k,		1 AB
R 34	57.02.5332	3.3 k,		1 AB
R 35	57.02.5332	3.3 k,		1 AB

Aenderungen		(1)	(2)	(3)	(4)	(5)
STUDER	Positionsliste	Erstellt: 4.5.73 wa		Gepf: 7.5.73 RJK		
REGENSDORF	IC- Decoder Print	bestückt	Blatt 2 Blätter 3			
ZÜRICH	Kopie für		Ersetzt durch: 1.080.391.00			

Pos.	Bauteil No.	Bezeichnung	Stk.	Bemerkung
R 36	57.02.5312	3.3 k, 10 %, .25 W,	CMA	1 AB
R 37				
R 38	57.02.5103	10 k,		1
R 39	57.02.5222	2.2 k,		1
TP 1	54.01.0010	Buchse, 2 mm,	sv	1
TP 2	54.01.0019		sv	1
TP 3	54.01.0014		gb	1
TP 4	54.01.0012		rt	1
TP 5	54.01.0019		sv	1
TP 6	54.01.0014		gb	1
TP 7	54.01.0019		sv	1
TP 8	54.01.0016		bl	1
TP 9	54.01.0019		sv	1
TP 10	54.01.0019		sv	1
TP 11	54.01.0014		gb	1
TP 12	54.01.0019		sv	1
TP 13	54.01.0019		sv	1
TP 14	54.01.0019		sv	1
TP 15	54.01.0012		rt	1
IC 1	50.05.0109	SN 7404 N		1
IC 2	50.05.0108	SN 7400 N		1
IC 3	50.05.0110	SN 7410 N		1
IC 4	50.05.0108	SN 7400 N		1
IC 5	50.05.0109	SN 7404 N		1
IC 6	50.05.0108	SN 7400 N		1
IC 7	50.05.0108	SN 7400 N		1
IC 8	50.05.0109	SN 7404 N		1
IC 9	50.05.0108	SN 7400 N		1

Aenderungen		(1)	(2)	(3)	(4)	(5)
STUDER	Positionsliste	Erstellt: 7.5.73 wa		Gepf: 7.5.73 RJK		
REGENSDORF	IC DECODER-PRINT	RESTUCKT	Blatt 3 Blätter 3			
ZÜRICH	Kopie für		Ersetzt durch: 1.080.391.00			

IC MEMORY AND COUNTER 1.080.393 GR 20 EL 9

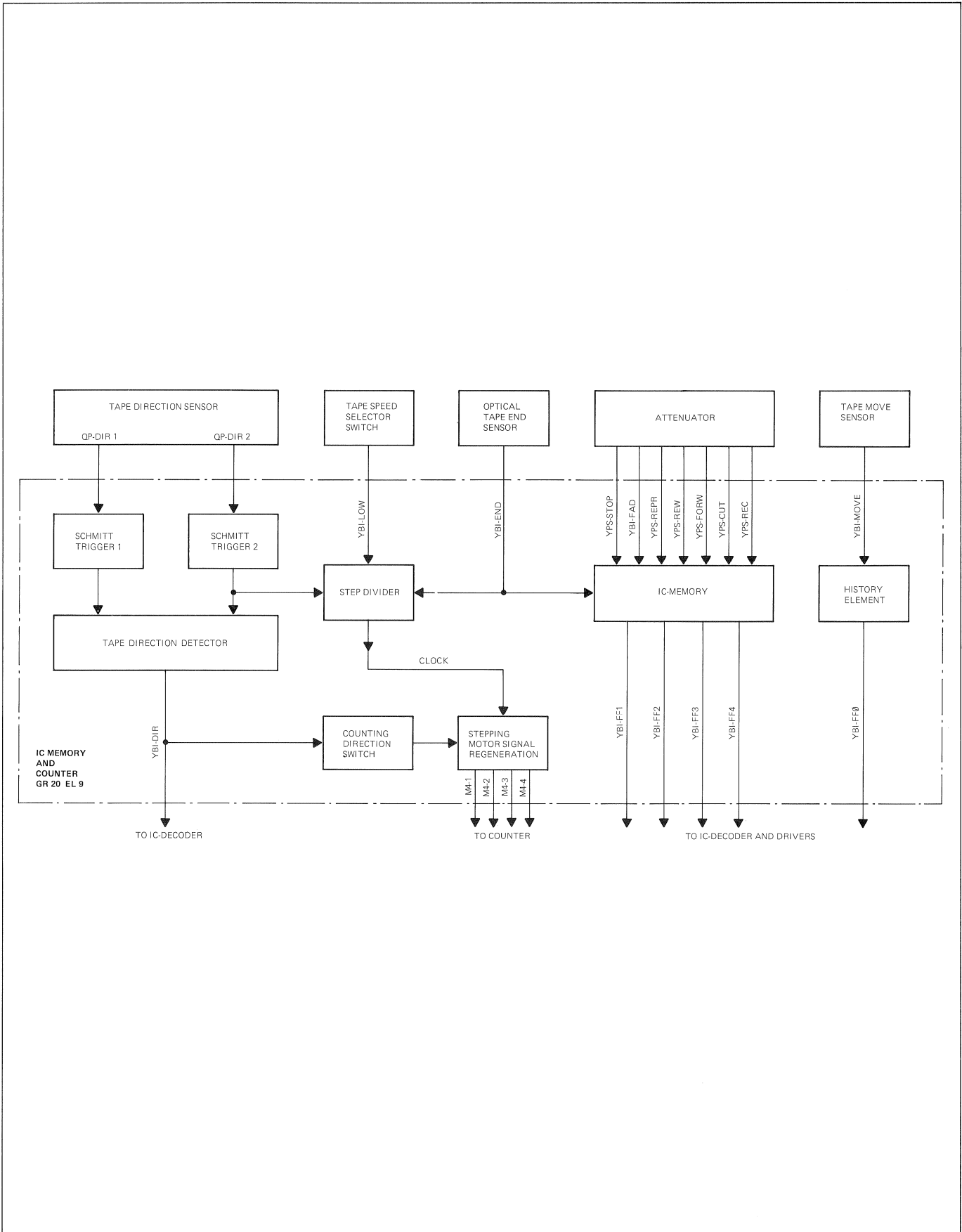

IC MEMORY AND COUNTER 1.080.393 GR 20 EL 9

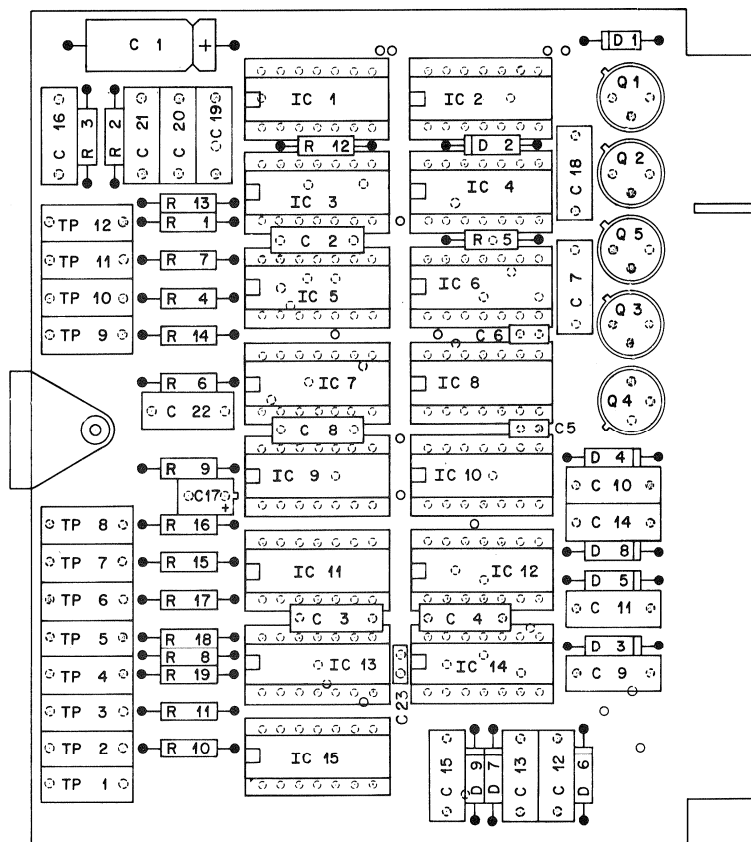

IC MEMORY AND COUNTER 1.080.393 GR 20 EL 9

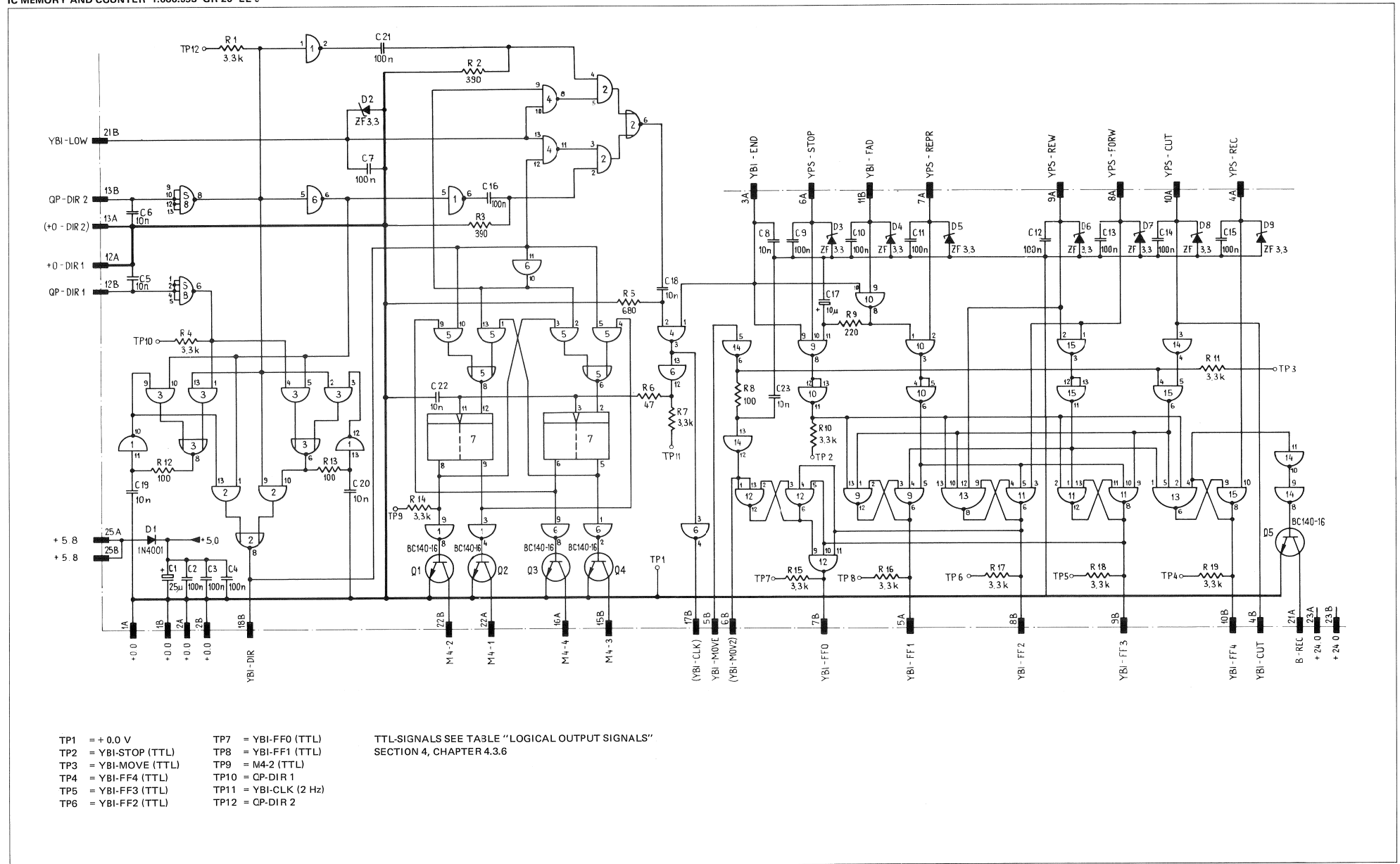

- | | |
|----------------------|-----------------------|
| TP1 = + 0.0 V | TP7 = YBI-FF0 (TTL) |
| TP2 = YBI-STOP (TTL) | TP8 = YBI-FF1 (TTL) |
| TP3 = YBI-MOVE (TTL) | TP9 = M4-2 (TTL) |
| TP4 = YBI-FF4 (TTL) | TP10 = QP-DIR 1 |
| TP5 = YBI-FF3 (TTL) | TP11 = YBI-CLK (2 Hz) |
| TP6 = YBI-FF2 (TTL) | TP12 = QP-DIR 2 |

TTL-SIGNALS SEE TABLE "LOGICAL OUTPUT SIGNALS" SECTION 4, CHAPTER 4.3.6

IC MEMORY AND COUNTER 1.080.393 GR 20 EL 9

Pos.	Bauteil No.	Bezeichnung	Stk.	Bemerkung
C 01	59.25.5220	22 u, +80 %, 40 V, RL	1	
C 02	59.99.0197	100 n, +80 %, KBR	1	
C 03	59.99.0197	100 n, +80 %	1	
C 04	59.99.0197	100 n, +80 %	1	
C 05	59.99.0181	10 n, +80 %, 50 V, 1	1	
C 06	59.99.0181	10 n, +80 %	1	
C 07	59.05.2104	100 n, 10 %, 100 V, MPC	1	
C 08	59.99.0197	100 n, +80 %, 25 W, KER	1	
C 09	59.05.2104	100 n, 10 %, 100 V, MPC	1	
C 10	59.05.2104	100 n, 10 %, 100 V, MPC	1	
C 11	59.05.2104	100 n, 10 %, 100 V, MPC	1	
C 12	59.05.2104	100 n, 10 %, 100 V, MPC	1	
C 13	59.05.2104	100 n, 10 %, 100 V, MPC	1	
C 14	59.05.2104	100 n, 10 %, 100 V, MPC	1	
C 15	59.05.2104	100 n, 10 %, 100 V, MPC	1	
C 16	59.05.2104	100 n, 10 %, 100 V, MPC	1	
C 17	59.10.4100	10 u, 20 %, 16 V, TA	1	
C 18	59.05.4103	10 n, 10 %, 250 V, MPC	1	
C 19	59.05.4103	10 n, 10 %, 250 V, MPC	1	
C 20	59.05.4103	10 n, 10 %, 250 V, MPC	1	
C 21	59.05.2104	100 n, 10 %, 100 V, MPC	1	
C 22	59.05.4103	10 n, 10 %, 250 V, MPC	1	
C 23	59.12.3103	10 n, +80 %, 40 V, KER	1	
D 01	50.04.0122	N 4001	1	
D 02	50.04.1107	3.3 V, 5 %, .4 W, Z	1	
D 03	50.04.1107	3.3 V, 5 %, .4 W, Z	1	
D 04	50.04.1107	3.3 V, 5 %, .4 W, Z	1	
D 05	50.04.1107	3.3 V, 5 %, .4 W, Z	1	
D 06	50.04.1107	3.3 V, 5 %, .4 W, Z	1	
D 07	50.04.1107	3.3 V, 5 %, .4 W, Z	1	
Änderungen ① 1.9.71 ② 16.11.72 ③ 13.7.75 ④ 27.2.74 ⑤ K. P. 75 J.F.				
STUDER Positionsliste Erteilt: 23.8.71 Bz				
REGENSDORF IC Memory-Print bestückt Geprüft: FJD				
ZÜRICH Blatt: 1 Blätter: 3				
Kopie für:		Ersatz für:	1.080.393.00	
Ersatz durch:		Ersatz durch:		

Pos.	Bauteil No.	Bezeichnung	Stk.	Bemerkung
D 08	50.04.1107	3.3 V, 5 %, .4 W, Z	1	
D 09	50.04.1107	3.3 V, 5 %, .4 W, Z	1	
IC 01	50.05.0200	SN 7404 N, 1	1	
IC 02	50.05.0112	SN 7451 N, 1	1	
IC 03	50.05.0112	SN 7451 N, 1	1	
IC 04	50.05.0108	SN 7400 N, 1	1	
IC 05	50.05.0112	SN 7451 N, 1	1	
IC 06	50.05.0200	SN 7404 N, 1	1	
IC 07	50.05.0113	SN 7474 N, 1	1	
IC 08	50.05.0121	SN 7413 N, 1	1	
IC 09	50.05.0110	SN 7410 N, 1	1	
IC 10	50.05.0108	SN 7400 N, 1	1	
IC 11	50.05.0110	SN 7410 N, 1	1	
IC 12	50.05.0110	SN 7410 N, 1	1	
IC 13	50.05.0111	SN 7420 N, 1	1	
IC 14	50.05.0200	SN 7404 N, 1	1	
IC 15	50.05.0108	SN 7400 N, 1	1	
Q 01	50.03.0316	RC 140 / 16, 1	1	
Q 02	50.03.0316	RC 140 / 16, 1	1	
Q 03	50.03.0316	RC 140 / 16, 1	1	
Q 04	50.03.0316	RC 140 / 16, 1	1	
Q 05	50.03.0316	RC 140 / 16, 1	1	
Änderungen ① 1.9.71 ② 12.8.74 J.F. ③				
STUDER Positionsliste Erteilt: 23.8.71 Bz				
REGENSDORF IC Memory-Print bestückt Geprüft: H				
ZÜRICH Blatt: 2 Blätter: 3				
Kopie für:		Ersatz für:	1.080.393.00	
Ersatz durch:		Ersatz durch:		

Pos.	Bauteil No.	Bezeichnung	Stk.	Bemerkung
R 01	57.02.5332	3.3 k, 10 %, .25 W, CMA	1	
R 02	57.02.5332	3.3 k, 10 %, .25 W, CMA	1	
R 03	57.02.5332	3.3 k, 10 %, .25 W, CMA	1	
R 04	57.02.5332	3.3 k, 10 %, .25 W, CMA	1	
R 05	57.02.5681	680, 10 %, .25 W, CMA	1	
R 06	57.02.5410	47, 10 %, .25 W, CMA	1	
R 07	57.02.5332	3.3 k, 10 %, .25 W, CMA	1	
R 08	57.02.5101	100, 10 %, .25 W, CMA	1	
R 09	57.02.5221	220, 10 %, .25 W, CMA	1	
R 10	57.02.5332	3.3 k, 10 %, .25 W, CMA	1	
R 11	57.02.5332	3.3 k, 10 %, .25 W, CMA	1	
R 12	57.02.5101	100, 10 %, .25 W, CMA	1	
R 13	57.02.5101	100, 10 %, .25 W, CMA	1	
R 14	57.02.5332	3.3 k, 10 %, .25 W, CMA	1	
R 15	57.02.5332	3.3 k, 10 %, .25 W, CMA	1	
R 16	57.02.5332	3.3 k, 10 %, .25 W, CMA	1	
R 17	57.02.5332	3.3 k, 10 %, .25 W, CMA	1	
R 18	57.02.5332	3.3 k, 10 %, .25 W, CMA	1	
R 19	57.02.5332	3.3 k, 10 %, .25 W, CMA	1	
FP 01	54.01.0010	Buchse, 2 mm, sv, 1	1	
FP 02	54.01.0012	Buchse, 2 mm, rt, 1	1	
FP 03	54.01.0019	Buchse, 2 mm, ws, 1	1	
FP 04	54.01.0014	Buchse, 2 mm, gb, 1	1	
FP 05	54.01.0014	Buchse, 2 mm, gb, 1	1	
FP 06	54.01.0014	Buchse, 2 mm, gb, 1	1	
FP 07	54.01.0016	Buchse, 2 mm, bl, 1	1	
FP 08	54.01.0014	Buchse, 2 mm, gb, 1	1	
FP 09	54.01.0019	Buchse, 2 mm, ws, 1	1	
FP 10	54.01.0019	Buchse, 2 mm, ws, 1	1	
FP 11	54.01.0019	Buchse, 2 mm, ws, 1	1	
FP 12	54.01.0019	Buchse, 2 mm, ws, 1	1	
Änderungen ① 1.9.71 ② 15.10.71 J.F. ③				
STUDER Positionsliste Erteilt: 23.8.71 Bz				
REGENSDORF IC Memory-Print bestückt Geprüft: H				
ZÜRICH Blatt: 3 Blätter: 3				
Kopie für:		Ersatz für:	1.080.393.00	
Ersatz durch:		Ersatz durch:		

ATTENUATOR AND PREAMPLIFIER 1.080.396 GR 20 EL 10

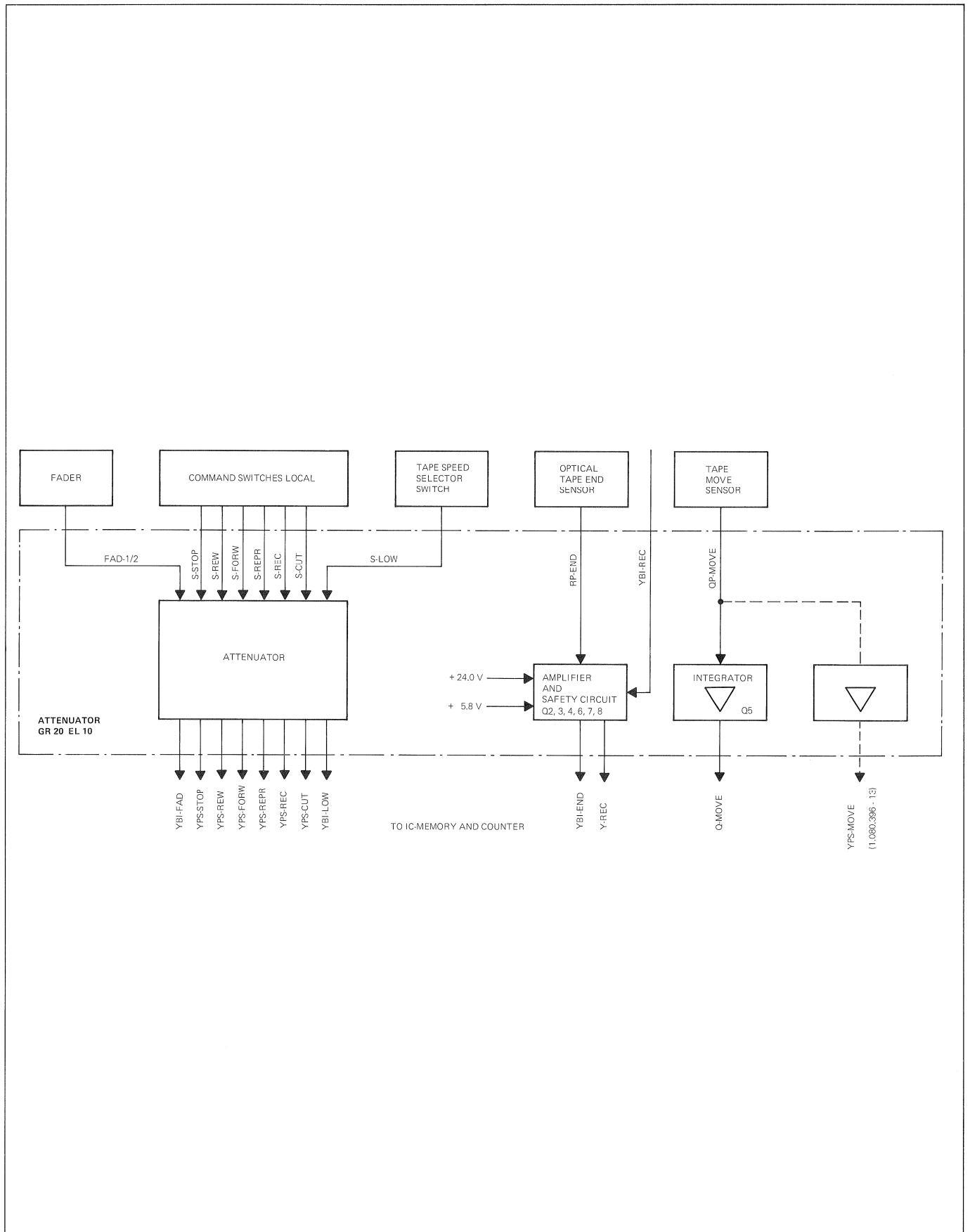

ATTENUATOR AND PREAMPLIFIER 1.080.396 GR 20 EL 10

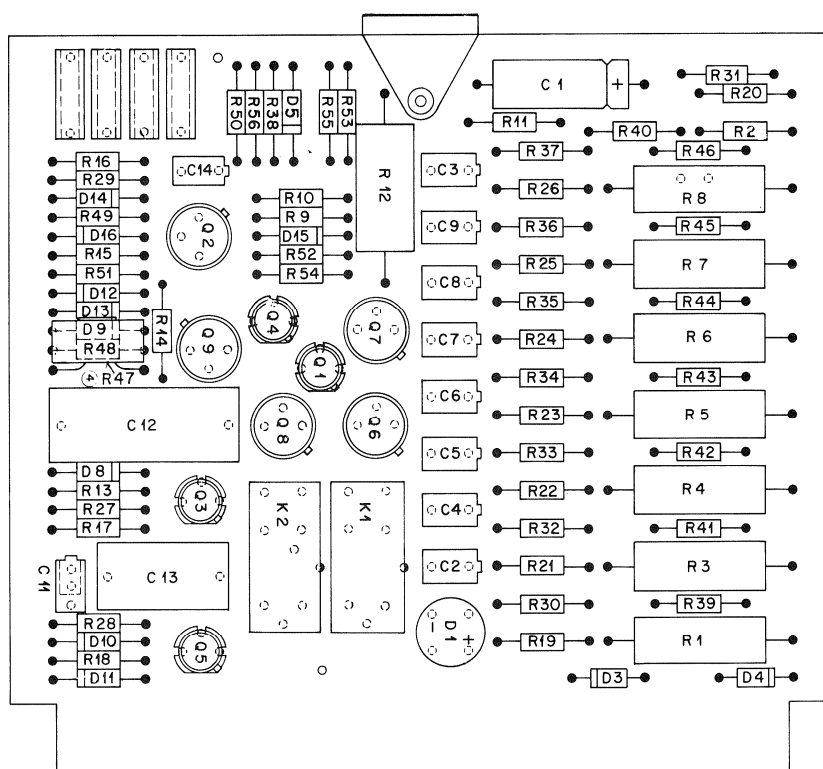

ATTENUATOR AND PREAMPLIFIER 1.080.396 GR 20 EL 10

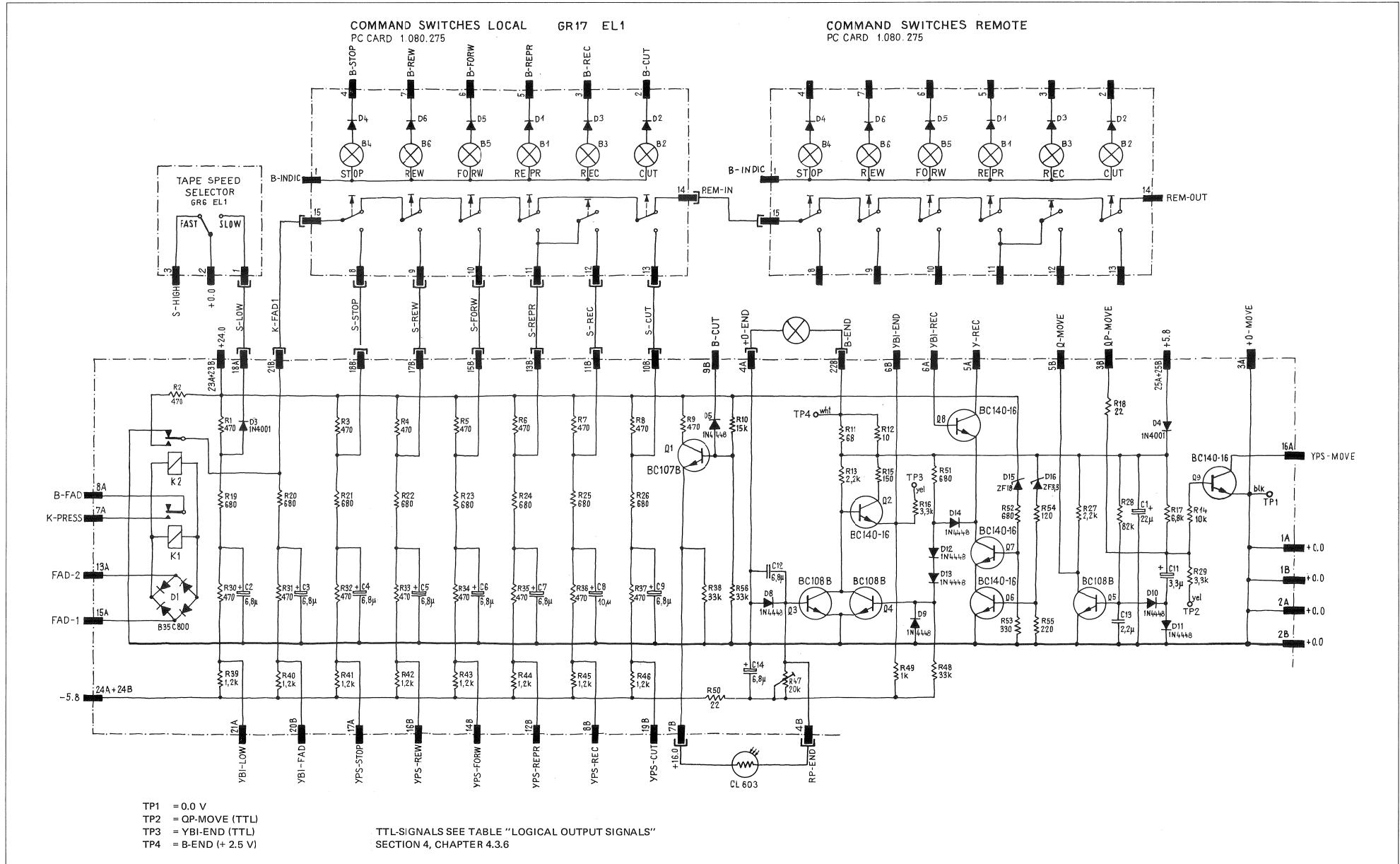

ATTENUATOR AND PREAMPLIFIER 1.080.396 GR 20 EL 10

Pos	Bauteil No.	Bezeichnung	Stk	Bemerkung
①	C 1	59.25.5220 22 p, +50 %, 40 7 ^u , EE	1	
	C 2	59.10.7689 6.8 p, 20 %, 35 7 ^u , TA	1	
	C 3	59.10.7689 6.8 p, 20 %, 35 7 ^u , TA	1	
	C 4	59.10.7689 6.8 p, 20 %, 35 7 ^u , TA	1	
	C 5	59.10.7689 6.8 p, 20 %, 35 7 ^u , TA	1	
	C 6	59.10.7689 6.8 p, 20 %, 35 7 ^u , TA	1	
	C 7	59.10.7689 6.8 p, 20 %, 35 7 ^u , TA	1	
	C 8	59.16.5100 10 p, 20 %, 35 7 ^u , TA	1	
	C 9	59.10.7689 6.8 p, 20 %, 35 7 ^u , TA	1	
	C 11	59.10.5339 3.3 p, 20 %, 20 7 ^u , TA	1	
	C 12	59.05.1685 6.8 p, 10 %, 63 7 ^u , MPC	1	
	C 13	59.05.1225 2.2 p, 10 %, 63 7 ^u , MPC	1	
	C 14	59.10.5689 6.8 p, 20 %, 20 7 ^u , TA	1	

Pos	Bauteil No.	Bezeichnung	Stk	Bemerkung
①	D 1	70.01.0222 B 35 C 800,	SI	1
	D 3	50.04.0122 1 N 4001,		1
	D 4	50.04.0122 1 N 4001,		1
	D 5	50.04.0125 1 N 4448	SI	1
	D 8	50.04.0125 1 N 4448	SI	1
	D 9	50.04.0125		1 nicht gesticht
	D 10	50.04.0125		1
	D 11	50.04.0125		1
	D 12	50.04.0125		1 nicht gesticht
	D 13	50.04.0125		1 nicht gesticht
	D 14	50.04.0125		1
	D 15	50.04.1122 18 V, 5 %, 4 M	Z	1

Anderungen ① 5, 5, 7, 14, 27, 2, 74, 21, 3, 12, 11, 12, 13, 14, 20, 2, 79, 31, 32, 33, 34, 35, 36, 37, 38, 39, 40, 41, 42, 43, 44, 45, 46, 47, 48, 49, 50, 51, 52, 53, 54, 55, 56, 57, 58, 59, 60, 61, 62, 63, 64, 65, 66, 67, 68, 69, 70, 71, 72, 73, 74, 75, 76, 77, 78, 79, 80, 81, 82, 83, 84, 85, 86, 87, 88, 89, 90, 91, 92, 93, 94, 95, 96, 97, 98, 99, 100

STUDER Positionenliste
 REGENSDORF ZÜRICH VORVERSTÄRKER-UND SPANNUNGSTEILER PRINTZ BEBET.
 Blatt 1 Blätter 4
 Kopie für: Ersatz für: Ersatz durch: 1.080.396.00

Pos	Bauteil No.	Bezeichnung	Stk	Bemerkung
①	D 16	50.04.1107 3.3 V, 5 %, 4 M	Z	1
	E 1	56.02.1001 24 V _h , 1 A, 1 U,		1
	E 2	56.02.1001 24 V _h , 1 A 1 U,		1
	C 1	50.03.0408 BC 107 h		1
	C 2	50.03.0316 BC 140 / 16		1
	C 3	50.03.0409 BC 108 h		1
	C 4	50.03.0409 BC 108 h		1
	C 5	50.03.0409 BC 108 h		1
	C 6	50.03.0316 BC 140 / 16		1
	C 7	50.03.0316 BC 140 / 16		1
	C 8	50.03.0316 BC 140 / 16		1
	C 9	50.03.0316 BC 140 / 16		1

Pos	Bauteil No.	Bezeichnung	Stk	Bemerkung
①	R 1	57.56.4471 470, 5 %, 5.5 W, DR		1
	R 2	57.02.5471 470, 10 %, .25 W, CMA		1
	R 3	57.56.4471 470, 5 %, 5.5 W, DR		1
	R 4	57.56.4471 470, 5 %, 5.5 W, DR		1
	R 5	57.56.4471 470, 5 %, 5.5 W, DR		1
	R 6	57.56.4471 470, 5 %, 5.5 W, DR		1
	R 7	57.56.4471 470, 5 %, 5.5 W, DR		1
	R 8	57.56.4471 470, 5 %, 5.5 W, DR		1
	R 9	57.02.5471 470, 10 %, .25 W, CMA		1
	R 10	57.02.5153 15k, 10 %, .25 W, CMA		1
	R 11	57.02.5680 68, 10 %, .25 W, CMA		1
	R 12	57.56.4100 10, 10 %, 5.5 W, DR		1
	R 13	57.02.5222 2.2 k, 10 %, .25 W, CMA		1
	R 14	57.02.5103 10 k, 10 %, .25 W, CMA		1
	R 15	57.02.5151 150, 10 %, .25 W, CMA		1
	R 16	57.02.5332 3.3 k, 10 %, .25 W, CMA		1
	R 17	57.02.5682 6.8 k, 10 %, .25 W, CMA		1
	R 18	57.02.5220 22, 10 %, .25 W, CMA		1
	R 19	57.02.5681 680, 10 %, .25 W, CMA		1
	R 20	57.02.5681 680, 10 %, .25 W, CMA		1

Anderungen ① 5, 5, 7, 14, 27, 2, 74, 21, 3, 12, 11, 12, 13, 14, 20, 2, 79, 31, 32, 33, 34, 35, 36, 37, 38, 39, 40, 41, 42, 43, 44, 45, 46, 47, 48, 49, 50, 51, 52, 53, 54, 55, 56, 57, 58, 59, 60, 61, 62, 63, 64, 65, 66, 67, 68, 69, 70, 71, 72, 73, 74, 75, 76, 77, 78, 79, 80, 81, 82, 83, 84, 85, 86, 87, 88, 89, 90, 91, 92, 93, 94, 95, 96, 97, 98, 99, 100

STUDER Positionenliste
 REGENSDORF ZÜRICH VORVERSTÄRKER-UND SPANNUNGSTEILER PRINTZ BEBET.
 Blatt 2 Blätter 4
 Kopie für: Ersatz für: Ersatz durch: 1.080.396.00

Pos	Bauteil No.	Bezeichnung	Stk	Bemerkung
	R 21	57.02.5681 680, 10 %, .25 W, CMA		1
	R 22	57.02.5681 680, 10 %, .25 W, CMA		1
	R 23	57.02.5681 680, 10 %, .25 W, CMA		1
	R 24	57.02.5681 680, 10 %, .25 W, CMA		1
	R 25	57.02.5681 680, 10 %, .25 W, CMA		1
	R 26	57.02.5681 680, 10 %, .25 W, CMA		1
	R 27	57.02.5222 2.2 k, 10 %, .25 W, CMA		1
	R 28	57.02.5823 82 k, 10 %, .25 W, CMA		1
	R 29	57.02.5332 3.3 k, 10 %, .25 W, CMA		1
	R 30	57.02.5471 470, 10 %, .25 W, CMA		1
	R 31	57.02.5471 470, 10 %, .25 W, CMA		1
	R 32	57.02.5471 470, 10 %, .25 W, CMA		1
	R 33	57.02.5471 470, 10 %, .25 W, CMA		1
	R 34	57.02.5471 470, 10 %, .25 W, CMA		1
	R 35	57.02.5471 470, 10 %, .25 W, CMA		1
	R 36	57.02.5471 470, 10 %, .25 W, CMA		1
	R 37	57.02.5471 470, 10 %, .25 W, CMA		1
	R 38	57.02.5333 3.3 k, 10 %, .25 W, CMA		1
	R 39	57.02.5122 1.2 k, 10 %, .25 W, CMA		1
	R 40	57.02.5122 1.2 k, 10 %, .25 W, CMA		1
	R 41	57.02.5122 1.2 k, 10 %, .25 W, CMA		1
	R 42	57.02.5122 1.2 k, 10 %, .25 W, CMA		1
	R 43	57.02.5122 1.2 k, 10 %, .25 W, CMA		1
	R 44	57.02.5122 1.2 k, 10 %, .25 W, CMA		1
	R 45	57.02.5122 1.2 k, 10 %, .25 W, CMA		1
	R 46	57.02.5122 1.2 k, 10 %, .25 W, CMA		1
	R 47	58.01.5203 20 K, 20 % fin		1 ② ③
	R 48	57.02.5333 33 k, 10 %, .25 W, CMA		1 nicht gesticht
	R 49	57.02.5102 1 k, 10 %, .25 W, CMA		1
	R 50	57.02.5220 22, 10 %, .25 W, CMA		1
	R 51	57.02.5681 680, 10 %, .25 W, CMA		1
	R 52	57.02.5681 680, 10 %, .25 W, CMA		1
	R 53	57.02.5221 330, 10 %, .25 W, CMA		1
	R 54	57.02.5121 120, 10 %, .25 W, CMA		1
	R 55	57.02.5221 220, 10 %, .25 W, CMA		1

Anderungen ① 5, 5, 7, 14, 27, 2, 74, 21, 3, 12, 11, 12, 13, 14, 20, 2, 79, 31, 32, 33, 34, 35, 36, 37, 38, 39, 40, 41, 42, 43, 44, 45, 46, 47, 48, 49, 50, 51, 52, 53, 54, 55, 56, 57, 58, 59, 60, 61, 62, 63, 64, 65, 66, 67, 68, 69, 70, 71, 72, 73, 74, 75, 76, 77, 78, 79, 80, 81, 82, 83, 84, 85, 86, 87, 88, 89, 90, 91, 92, 93, 94, 95, 96, 97, 98, 99, 100

STUDER Positionenliste
 REGENSDORF ZÜRICH VORVERSTÄRKER-UND SPANNUNGSTEILER PRINTZ BEBET.
 Blatt 3 Blätter 4
 Kopie für: Ersatz für: Ersatz durch: 1.080.396.00

Pos	Bauteil No.	Bezeichnung	Stk	Bemerkung
	R 56	57.02.5333 33 k, 10 %, .25 W, CMA		1
	TP 1	54.01.0010 Buchse, 2 mm, sw,		1
	TP 2	54.01.0014 Buchse, 2 mm, gb,		1
	TP 3	54.01.0014 Buchse, 2 mm, gb,		1
	TP 4	54.01.0019 Buchse, 2 mm, wa,		1

Anderungen ① 5, 5, 7, 14, 27, 2, 74, 21, 3, 12, 11, 12, 13, 14, 20, 2, 79, 31, 32, 33, 34, 35, 36, 37, 38, 39, 40, 41, 42, 43, 44, 45, 46, 47, 48, 49, 50, 51, 52, 53, 54, 55, 56, 57, 58, 59, 60, 61, 62, 63, 64, 65, 66, 67, 68, 69, 70, 71, 72, 73, 74, 75, 76, 77, 78, 79, 80, 81, 82, 83, 84, 85, 86, 87, 88, 89, 90, 91, 92, 93, 94, 95, 96, 97, 98, 99, 100

STUDER Positionenliste
 REGENSDORF ZÜRICH VORVERSTÄRKER-UND SPANNUNGSTEILER PRINTZ BEBET.
 Blatt 4 Blätter 4
 Kopie für: Ersatz für: Ersatz durch: 1.080.396.00

ZERO LOCATOR 1.080.395 GR 20 EL 11

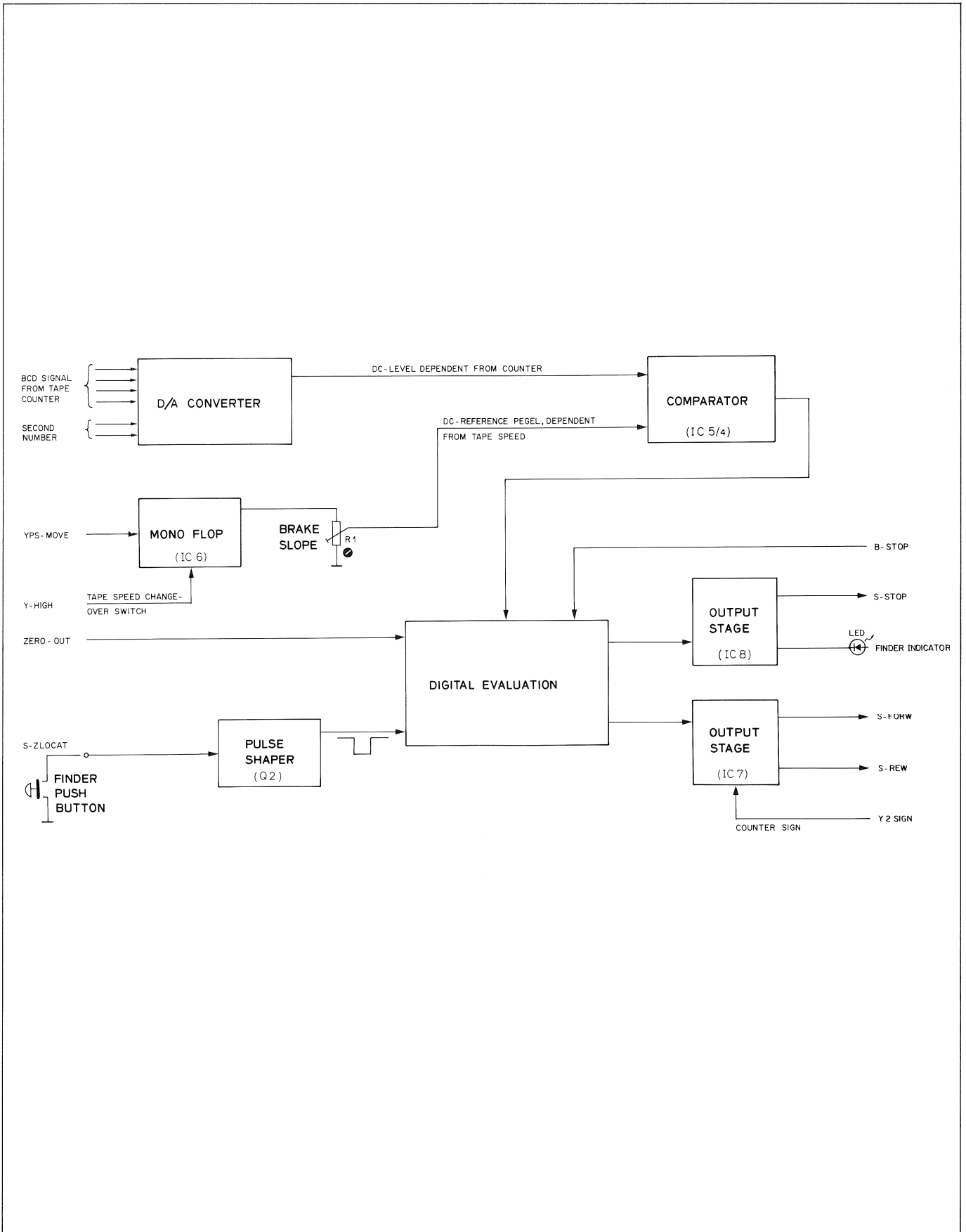

ZERO LOCATOR 1.080.395 GR 20 EL 11

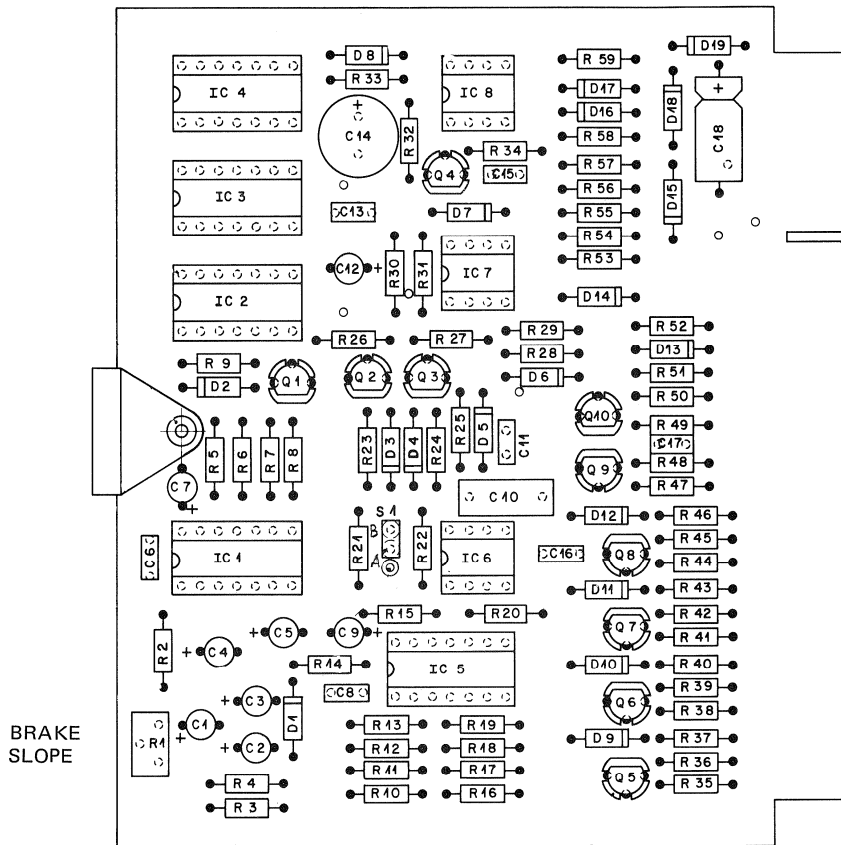

S1 POS A = 7.5/15''
POS B = 15/30''

ZERO LOCATOR 1.080.395 GR 20 EL 11

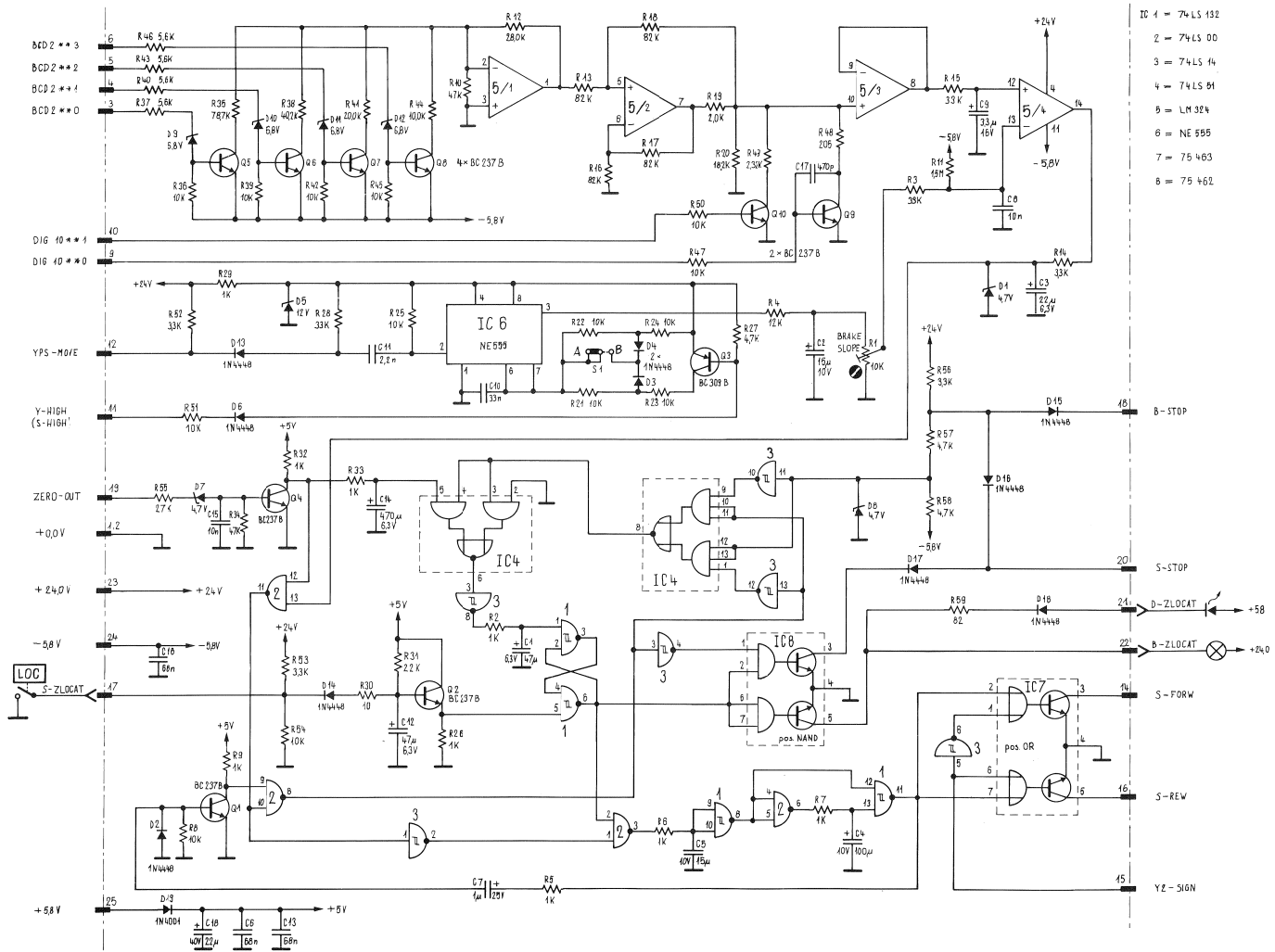

S1 POS A = 7.5/15"
 POS B = 15/30"

ZERO LOCATOR 1.080.395 GR 20 EL 11

POS NO	PART NO	VALUE	SPECIFICATIONS	EQUIVALENT MFR
C 01	59.36.1470	47 pF	6,3 V ± 20% TA	
C 02	59.36.2150	15	10 V	
C 03	59.30.2220	22	6,3 V ±20-50%	
C 04	59.30.3101	100	10 V ±20-50%	
C 05	59.36.2150	15	10 V ± 20%	CFR
C 06	59.99.0205	0,068	50 V	CFR
C 07	59.36.4109	1	25 V ± 20% TA	
C 08	59.32.3103	0,01	40 V ±20-100% CFR	
C 09	59.30.4339	5,3	16 V ±20-50% TA	
C 10	59.99.0314	0,033	250 V ± 2%	
C 11	59.32.2222	2200 pF	40 V ±20-100% CFR	
C 12	59.36.1470	47 pF	6,3 V ± 20%	TA
C 13	59.99.0205	0,068	50 V	CFR
C 14	59.22.2471	470	6,3 V ±10-100% FL	
C 15	59.22.3103	0,03	40 V ±20-100% CFR	
C 16	59.99.0205	0,068	50 V	CFR
C 17	59.32.4471	470 pF	50 V ± 20%	CFR
C 18	59.25.5220	22 pF	60 V ±10-50% FL	
D 03	50.04.1123	4,7 V	5%	
D 02	50.04.0125	1 N 4448	50 V, 100 mA	N 103
D 03	50.04.0125	1 N 4448		
D 04	50.04.0125	1 N 4448		
D 05	50.04.1117	12 V	5%	
D 06	50.04.0125	1 N 4448	50 V, 100 mA	N 103
D 07	50.04.1123	4,7 V	5%	
D 08	50.04.1123	4,7 V		
D 09	50.04.1102	5,8 V		
D 10	50.04.1102	5,8 V		
D 11	50.04.1102	5,8 V		
D 12	50.04.1102	5,8 V		
D 13	50.04.0125	1 N 4448	50 V, 100 mA	N 103
D 14	50.04.0125	1 N 4448		
D 15	50.04.0125	1 N 4448		
D 16	50.04.0125	1 N 4448		
D 17	50.04.0125	1 N 4448		
D 18	50.04.0125	1 N 4448		
D 19	50.04.0122	1 N 4001	50 V, 1 A	
IC 1	50.06.0132	S87418132	4 NANO, Schmitt-Trigger	
IC 2	50.06.0000	S8741300	4 NANO	
IC 3	50.06.0014	S8741814	Hex. Schmitt-Trigger Inv.	
IC 4	50.06.0051	S8741851		

PA -antal				
Chim-Ceramic				
ML -Electrolytic				
1.10.76	Schr/gv/4			
ING DATE	NAME			
STUDER Zero - Locator		1.080.395	PAGE 1 of 3	

POS NO	PART NO	VALUE	SPECIFICATIONS	EQUIVALENT MFR
IC 5	50.05.0199	LM 324	CURD OP-AMP	ONLY, NS
IC 6	50.05.0158	NE 555	TIMER	
IC 7	50.05.0201	S875463	DUAL OR INVERTER	
IC 8	50.05.0227	S875462	DUAL NAND INVERTER	
Q 01	50.03.0436	BC 237 B		BC 307 B
Q 02	50.03.0436	BC 237 B		
Q 03	50.03.0319	BC 253 B		BC 309 B
Q 04	50.03.0436	BC 237 B		BC 107 B
Q 05	50.03.0436	BC 237 B		
Q 06	50.03.0436	BC 237 B		
Q 07	50.03.0436	BC 237 B		
Q 08	50.03.0436	BC 237 B		
Q 09	50.03.0436	BC 237 B		
Q 0	50.03.0436	BC 237 B		
R 01	58.01.7103	10 K	LEN, 10%	5%
R 02	57.41.4102	1 K		5% .25W
R 03	57.41.4131	33 K		
R 04	57.41.4133	12 K		
R 05	57.41.4102	1 K		
R 06	57.41.4102	1 K		
R 07	57.41.4102	1 K		
R 08	57.41.4103	10 K		
R 09	57.41.4102	1 K		
R 10	57.41.4473	47 K		
R 11	57.41.4158	4,7 K		
R 12	57.39.2802	28 K	1% .25W MF	
R 13	57.41.4823	82 K	5% .25W	
R 14	57.41.4332	82 K		
R 15	57.41.4333	33 K		
R 16	57.41.4823	82 K		
R 17	57.41.4823	82 K		
R 18	57.41.4823	82 K		
R 19	57.39.2002	2,0 K	1% .25W MF	
R 20	57.39.2802	18,0 K		
R 21	57.41.4103	10 K	5% .25W	
R 22	57.41.4103	10 K		
R 23	57.41.4103	10 K		
R 24	57.41.4103	10 K		
R 25	57.41.4103	10 K		
R 26	57.41.4109	1 K		
R 27	57.41.4472	4,7 K		
R 28	57.41.4133	33 K		

MP-Metalfilm				
1.10.76	Schr/gv/4			
ING DATE	NAME			
STUDER Zero - Locator		1.080.395	PAGE 1 of 3	

POS NO	PART NO	VALUE	SPECIFICATIONS	EQUIVALENT MFR
R 29	57.41.4102	1 K	5% .25W	
R 30	57.41.4100	10 Ω		
R 31	57.41.4223	22 K		
R 32	57.41.4102	1 K		
R 33	57.41.4102	1 K		
R 34	57.41.4473	47 K		
R 35	57.39.2872	78,7K	1% .25W MF	
R 36	57.41.4103	10 K	5% .25W	
R 37	57.41.4562	5,6 K		
R 38	57.39.4002	40,2K	1% .25W MF	
R 39	57.41.4103	10 K	5% .25W	
R 40	57.41.4562	5,6 K		
R 41	57.39.4002	20,0K	1% .25W MF	
R 42	57.41.4103	10 K	5% .25W	
R 43	57.41.4562	5,6 K		
R 44	57.39.1002	10,0K	1% .25W MF	
R 45	57.41.4103	10 K	5% .25W	
R 46	57.41.4562	5,6 K		
R 47	57.41.4103	10 K		
R 48	57.39.2050	205 Ω	1% .25W MF	
R 49	57.39.2321	2,32K		
R 50	57.41.4103	10 K	5% .25W	
R 51	57.41.4103	10 K		
R 52	57.41.4132	3,3 K		
R 53	57.41.4332	3,3 K		
R 54	57.41.4103	10 K		
R 55	57.41.4273	27 K		
R 56	57.41.4332	3,3 K		
R 57	57.41.4472	4,7 K		
R 58	57.41.4472	4,7 K		
R 59	57.41.4820	82 Ω		

MP-Metalfilm				
1.10.76	Schr/gv/4			
ING DATE	NAME			
STUDER Zero - Locator		1.080.395	PAGE 3 of 3	

CONTENTS

DESCRIPTION	SCHEMATIC NO.	SECTION/PAGE
GENERAL		6
STUDER ELECTRONIC CARDS		6/3
PRESENTATION OF GROUPS		6/5
REMOTE MODE CONTROL		GR 22 EL 22 6/6
CUTTER CONTROL ASSEMBLY		GR 19 EL 21 6/7
POWER SUPPLY UNIT	1.080.320/322	GR 1/2 6/8
STABILIZER (TAPE TRANSPORT)	1.080.370-81	GR 20 EL 2 6/11
STABILIZER 2 CHANNEL (AUDIO)	1.080.988	6/15
STABILIZER 4 CHANNEL (AUDIO) A80 RTQ	1.080.964-81	6/17
COMMAND SWITCH BOARD	1.080.275	GR 17 6/19
SPEED CONVERTER BOARD	1.080.979-81	6/21
BASIS BOARD/COUNTER	1.228.812	GR 18 6/23
COUNTER DECODER	1.228.811	GR 18 6/27
COUNTER	1.228.813	GR 18 6/31
DISPLAY	1.228.814	GR 18 6/31
TAPE TRANSPORT CONTROL		7
TAPE TRANSPORT CONTROL/BLOCK DIAGM A80 R		7/3
PRESSURE ROLLER ASSEMBLY	1.080.124	GR 15 EL 1 7/4
TAPE TENSION CONTROL ASSEMBLY L/R	1.080.142/146	GR 11/12 EL 1 7/5
OPTICAL TAPE END SENSOR		GR 30 EL 1 7/6
TAPE MOVE AND DIRECTION SENSOR UNIT	1.080.181	GR 14 EL 1/2 7/7
CONTACTOR	1.080.381	GR 20 EL 4 7/11
SPOOLING MOTOR CONTROL 1/4" + 1/2" (7,5 - 15 ips)	1.080.383	GR 20 EL 5 7/15
SPOOLING MOTOR CONTROL 1/4" + 1/2" (15 - 30 ips)	1.080.385-81	GR 20 EL 5 7/19
CAPSTAN SERVO WITH VARIABLE SPEED CONTROL	1.080.372/374/377	GR 20 EL 6 7/23
IC DECODER AND DRIVERS	1.080.391	GR 20 EL 8 7/27
IC MEMORY AND COUNTER	1.080.393	GR 20 EL 9 7/31
ATTENUATOR AND PREAMPLIFIER	1.080.396	GR 20 EL 10 7/35
ZERO LOCATOR	1.080.395	GR 20 EL 11 7/39
AUDIO		8
AUDIO BLOCK DIAGRAM WITH STANDARD CONNECTOR PANEL		8/3
AUDIO BLOCK DIAGRAM WITH MONO/STEREO CONNECTOR PANEL		8/4
AUDIO BLOCK DIAGRAM WITH VU-METER PANEL		8/5
AUDIO BASIS BOARD / 2 CHANNEL	1.080.980	8/7
AUDIO BASIS BOARD / 4 CHANNEL A80 RTQ	1.080.962	8/8
WIRING DIAGRAMS HEADBLOCK ASSEMBLIES		8/9
REPRODUCE AMPLIFIER	1.080.986	8/11
RECORD AMPLIFIER	1.080.982	8/15
OSCILLATOR STEREO	1.080.984	8/19
OSCILLATOR 2 TRACK	1.080.987	8/23
OSCILLATOR 4 CHANNEL A80 RTQ	1.080.965	8/27
PILOT TONE AMPLIFIER MK II	1.080.932	8/29
CONNECTION PANEL (STANDARD) USA/EURO	1.080.989/997	8/33
CONNECTION PANEL (MONO/STEREO) USA/EURO	1.080.994/998	8/37
CONNECTION PANEL (VU-METER PANEL) USA/EURO	1.080.993/991	8/41
VU-METER PANEL	1.080.950	8/43
EARLIER SCHEMATICS		9

AUDIO BLOCK DIAGRAM WITH STANDARD CONNECTION PANEL

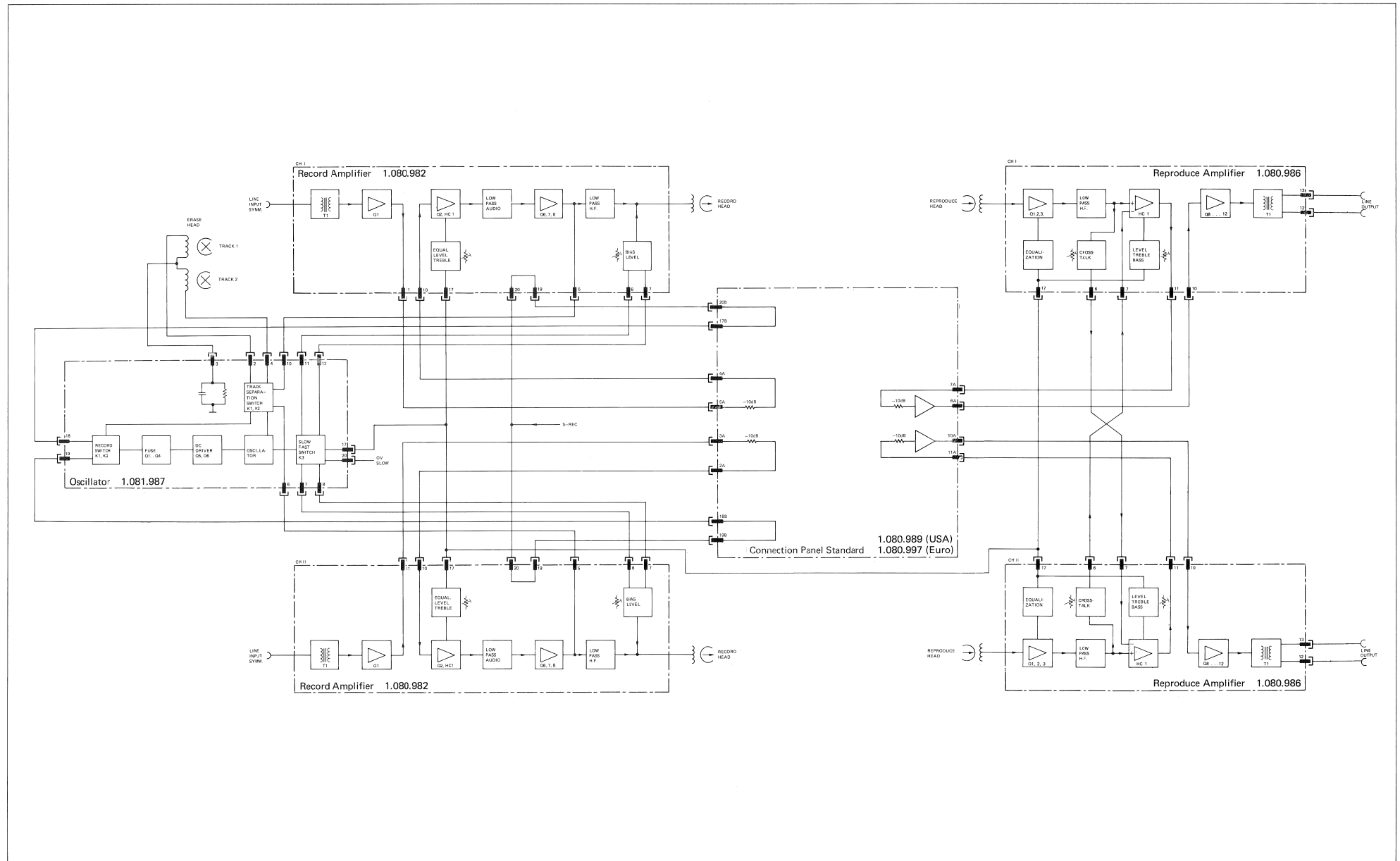

AUDIO BLOCK DIAGRAM WITH MONO/STEREO CONNECTION PANEL

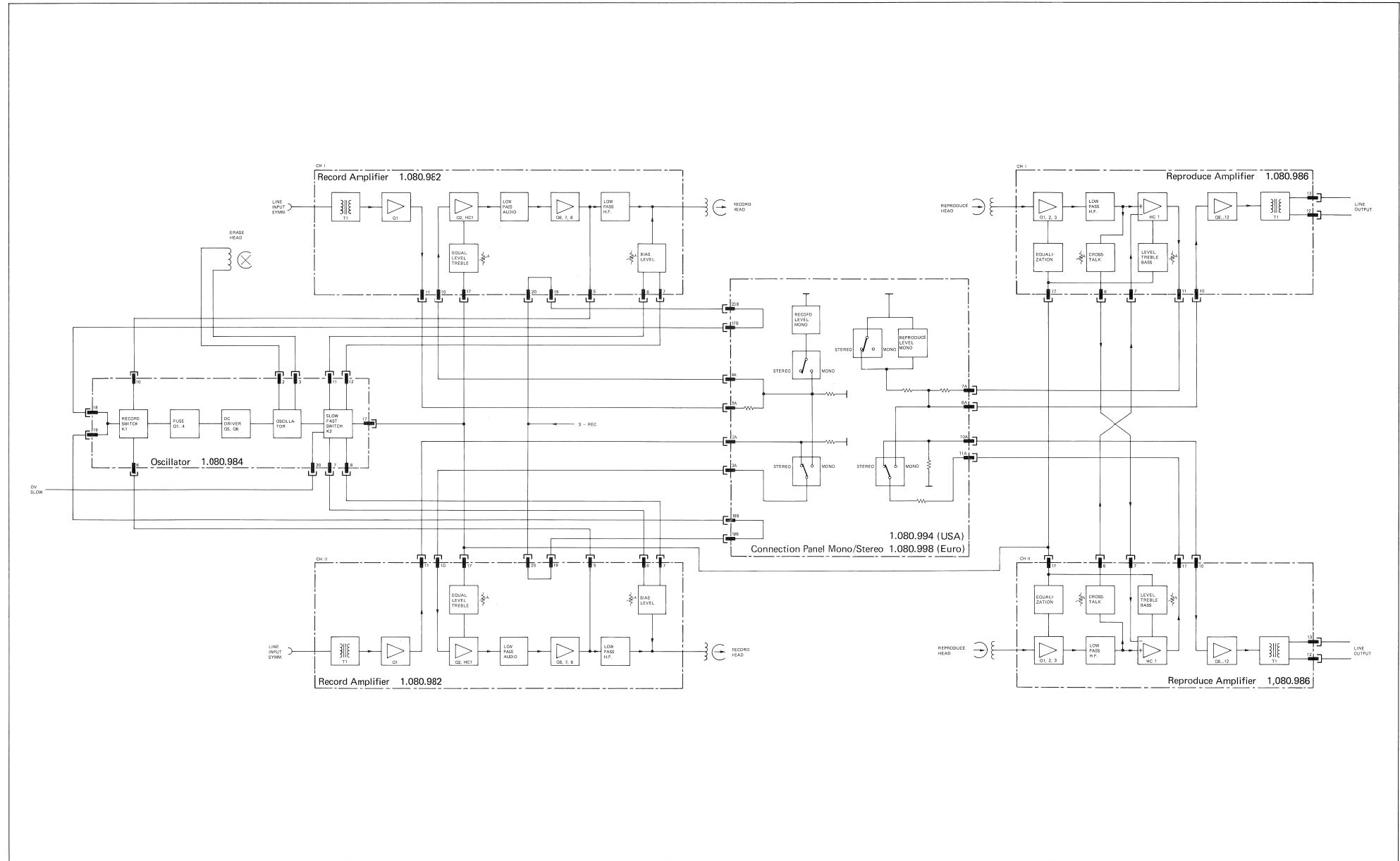

AUDIO BLOCKDIAGRAM WITH VU-METER PANEL

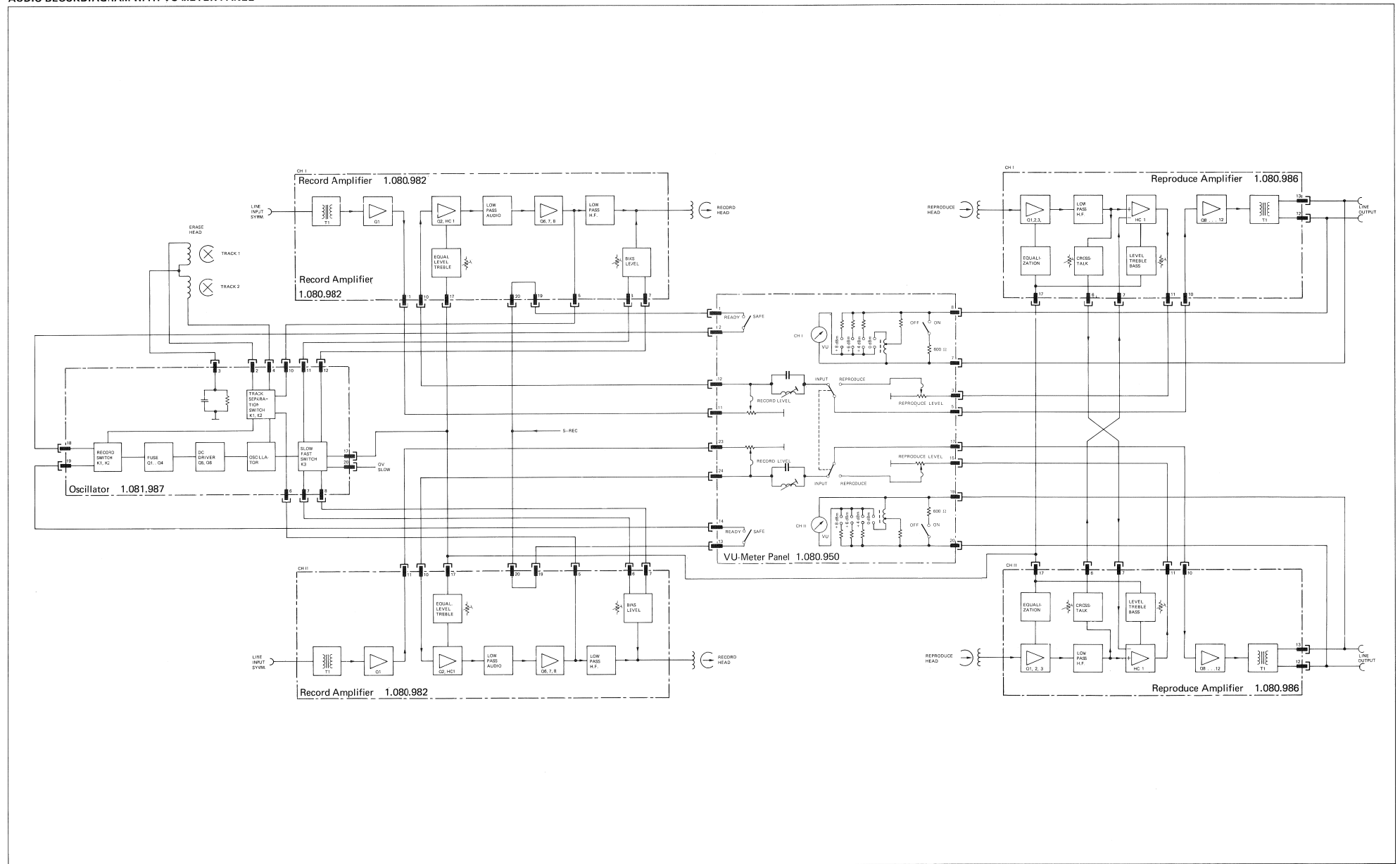

AUDIO BASIS BOARD / 2 CHANNEL 1.080.980

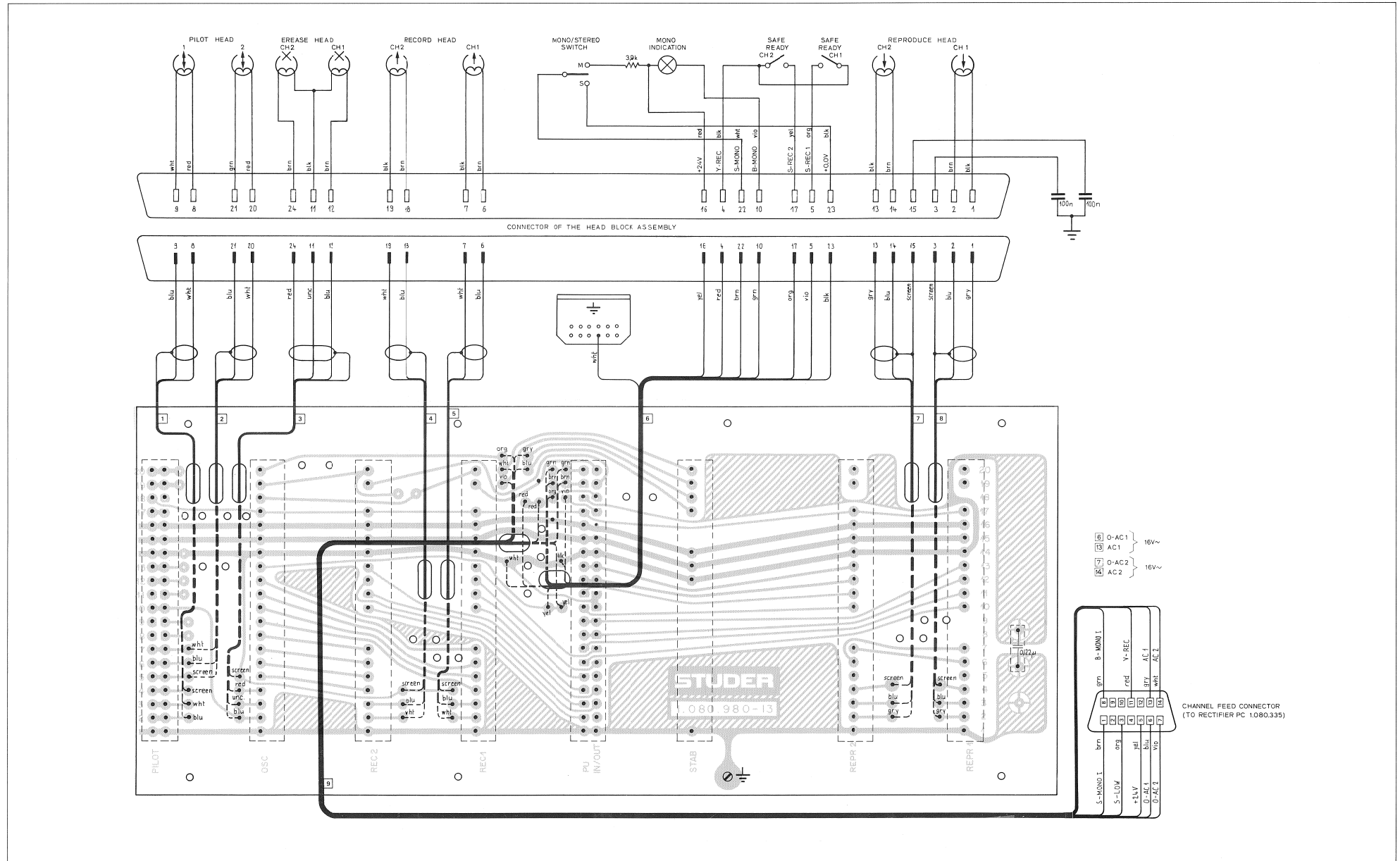

AUDIO BASIS BOARD / 4 CHANNEL 1.080.962

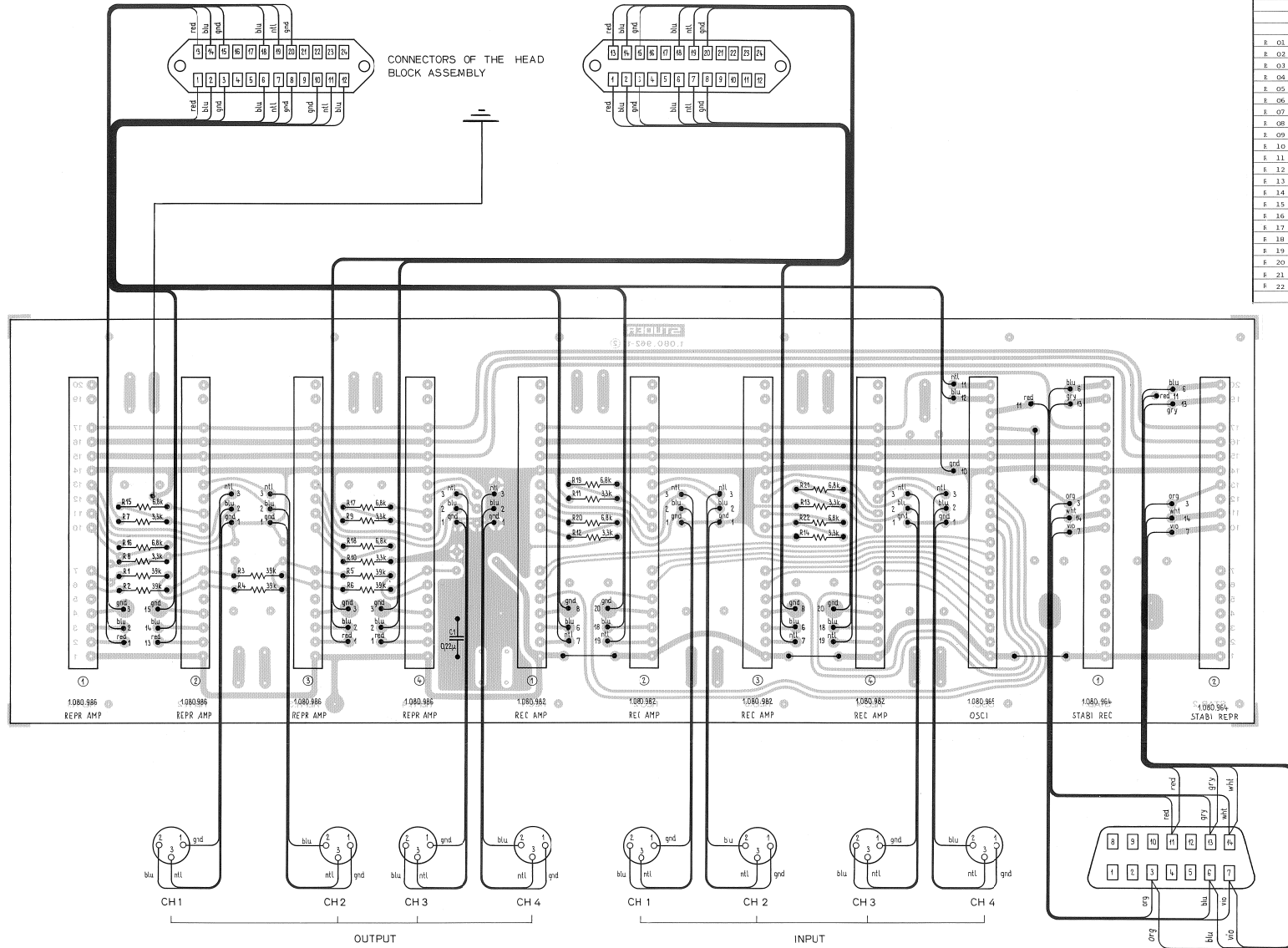

Pos.	Bauteil No.	Bezeichnung	Stk	Bemerkung
c 01	57.31.1224	c 0,22 u, 20%, 100 v, MPBTP	1	
R 01	57.02.5393	R 39 K, 10%, 25 w, CMA	1	
R 02	57.02.5393	R 39 K	1	
R 03	57.02.5393	R 39 K	1	
R 04	57.02.5393	R 39 K	1	
R 05	57.02.5393	R 39 K	1	
R 06	57.02.5393	R 39 K	1	
R 07	57.02.5332	R 3,3 K	1	
R 08	57.02.5332	R 3,3 K	1	
R 09	57.02.5332	R 3,3 K	1	
R 10	57.02.5332	R 3,3 K	1	
R 11	57.02.5332	R 3,3 K	1	
R 12	57.02.5332	R 3,3 K	1	
R 13	57.02.5332	R 3,3 K	1	
R 14	57.02.5332	R 3,3 K	1	
R 15	57.02.5682	R 6,8 K	1	
R 16	57.02.5682	R 6,8 K	1	
R 17	57.02.5682	R 6,8 K	1	
R 18	57.02.5682	R 6,8 K	1	
R 19	57.02.5682	R 6,8 K	1	
R 20	57.02.5682	R 6,8 K	1	
R 21	57.02.5682	R 6,8 K	1	
R 22	57.02.5682	R 6,8 K	1	

CHANNEL FEED CONNECTOR

WIRING DIAGRAMS HEADBLOCK ASSEMBLIES

Vollspur, MONO
full track mono

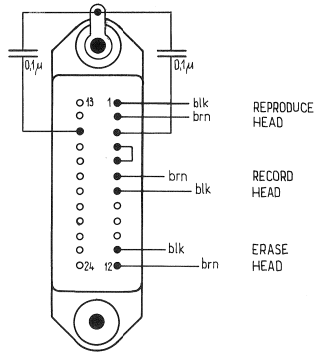

REPRODUCE HEAD

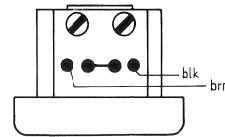

RECORD HEAD

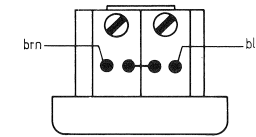

ERASE HEAD

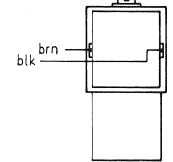

Vollspur, MONO
mit Pilotton
full track mono
with pilottone

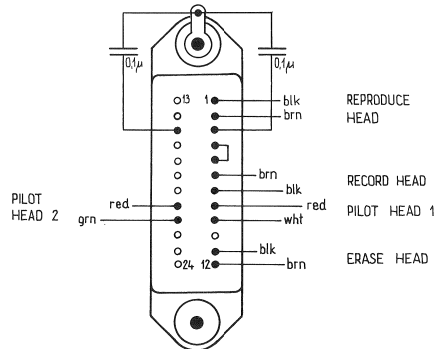

REPRODUCE HEAD

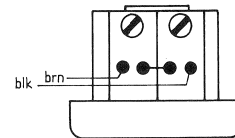

PILOT HEAD

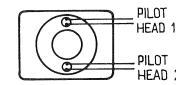

RECORD HEAD

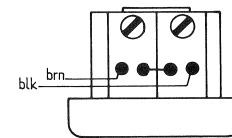

ERASE HEAD

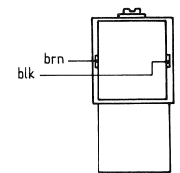

STEREO

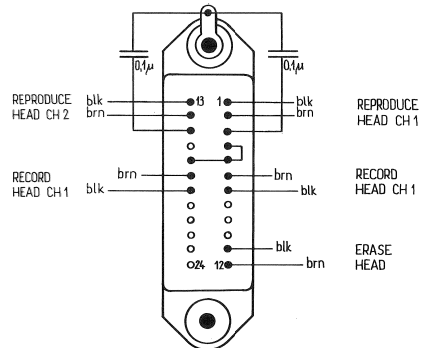

REPRODUCE HEAD

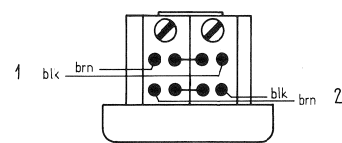

RECORD HEAD

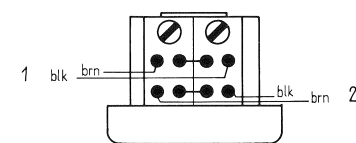

ERASE HEAD

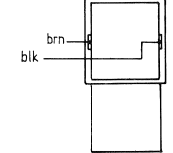

WIRING DIAGRAMS HEADBLOCK ASSEMBLIES

2-Spur mit
Spurwahlschalter

two track with
individual track
selection

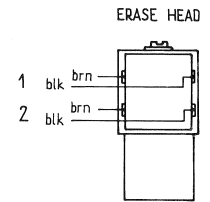
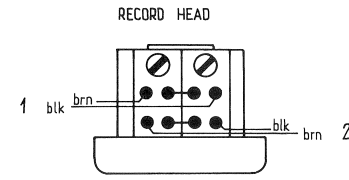
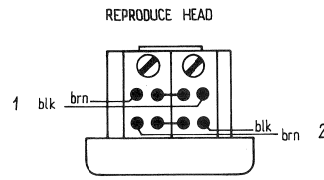
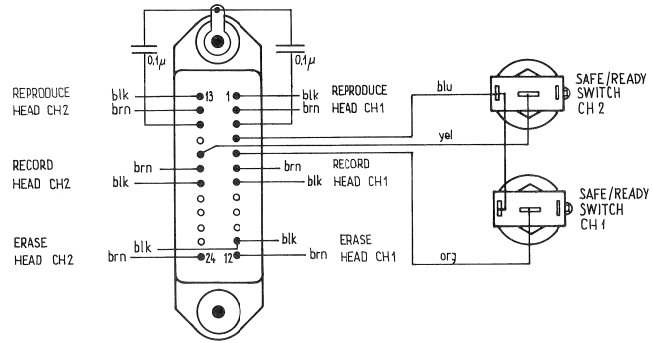

STEREO mit
MONO-STEREO
Schalter

STEREO with
MONO-STEREO
switch

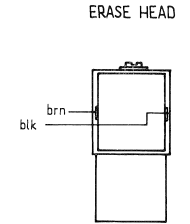
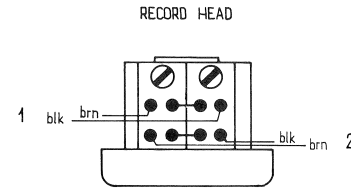
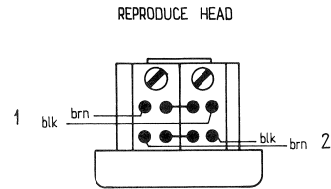
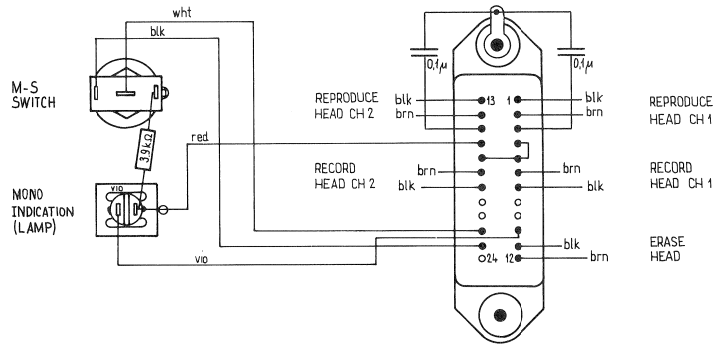

REPRODUCE AMPLIFIER 1.080.986

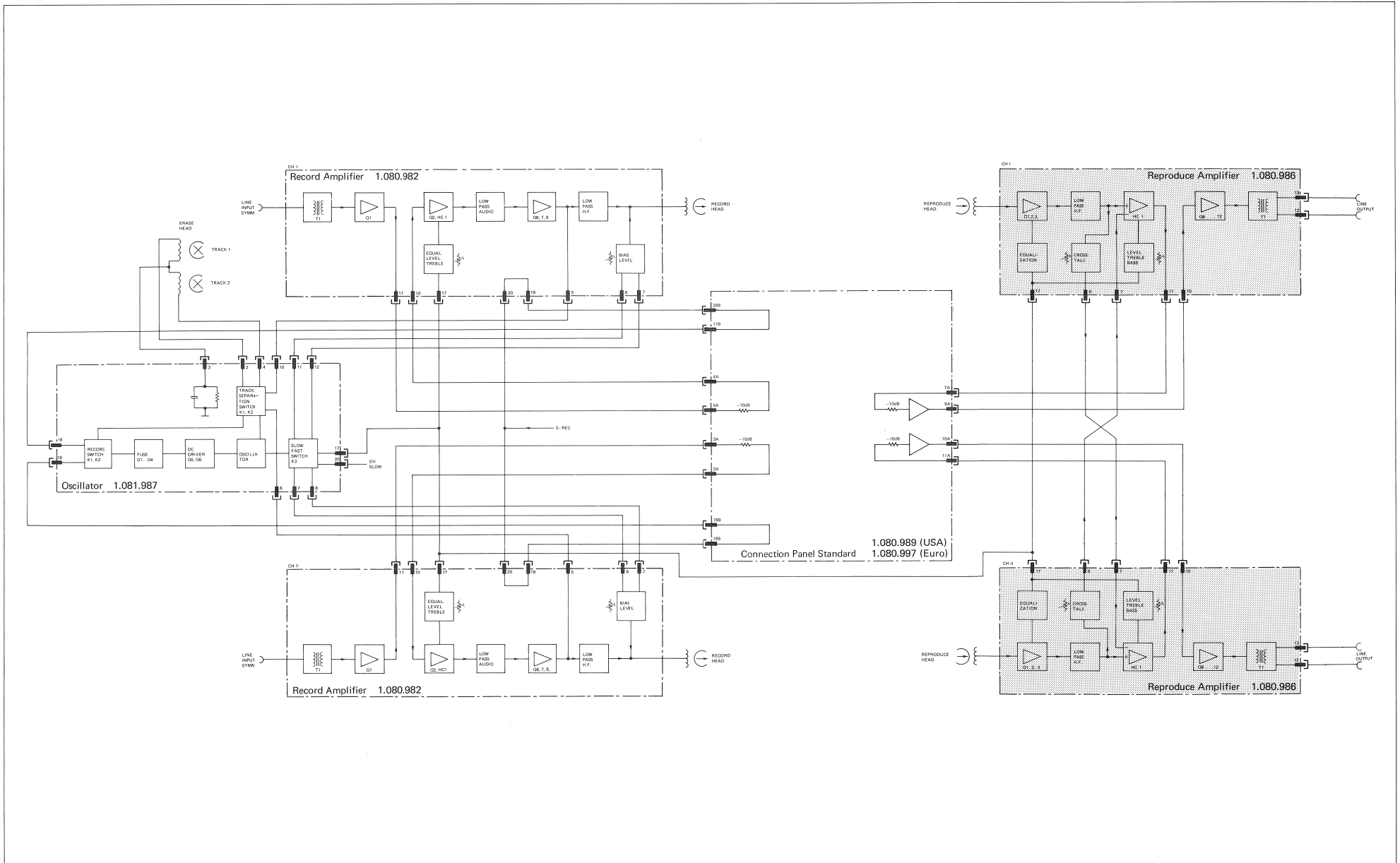

REPRODUCE AMPLIFIER 1.080.986

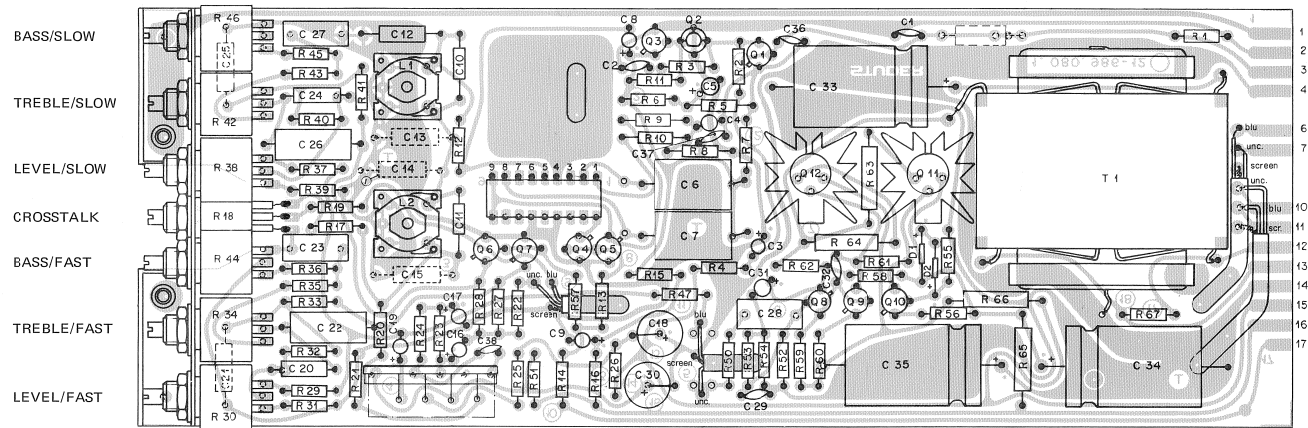

REPRODUCE AMPLIFIER 1.080.986

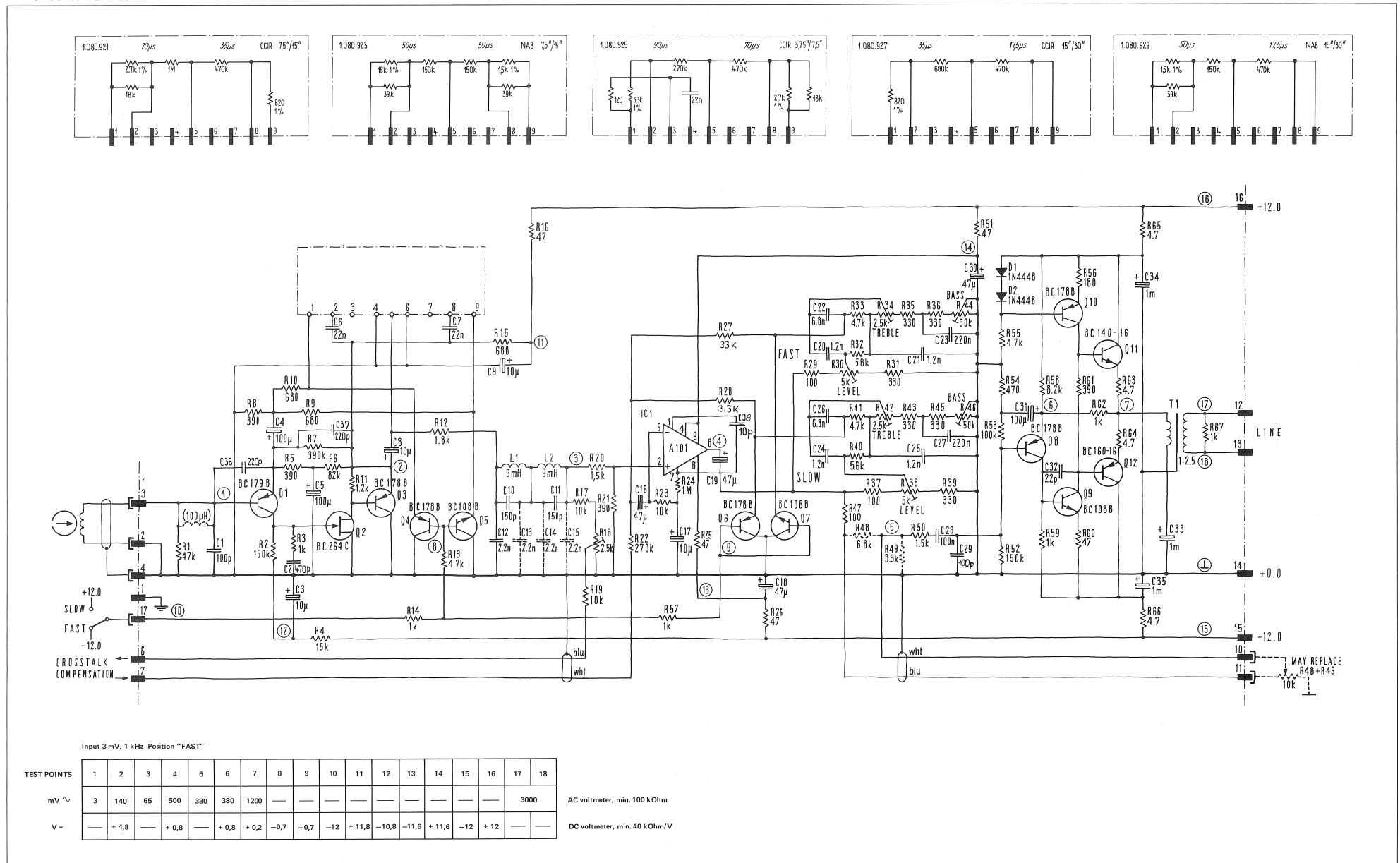

REPRODUCE AMPLIFIER 1.080.986

Pos.	Bauteil No.	Bezeichnung	Stk	Bemerkung
④	C 01	59.32.0101 C 100 F, 20%, 500 V, KBR	1	
	C 02	59.32.1471 C 470 F, 80%, 25 V, KBR	1	
	C 03	59.30.4100 C 10 U, 50%, 16 V, TA	1	
	C 04	59.30.1101 C 100 U, 3 V, 1		
	C 05	59.30.1101 C 100 U, 1		
⑥	C 06	59.08.7223 C 22 N, 1%, 63 V, PS	1	
⑥	C 07	59.08.7223 C 22 N, 1		
	C 08	59.30.4100 C 10 U, 50%, 16 V, TA	1	
	C 09	59.30.4100 C 10 U, 1		
	C 10	59.04.7151 C 150 F, 5%, 63 V, PS	1	
	C 11	59.04.7151 C 150 F, 1		
③	C 12	59.04.7222 C 2.2 N, 25 V, 1		
③	C 13	59.04.7222 C 2.2 N, 1		wird in der Serie nicht bestellbar
③	C 14	59.04.7222 C 2.2 N, 1		
③	C 15	59.04.7222 C 2.2 N, 1		
	C 16	59.30.1470 C 47 U, 50%, 3 V, TA	1	
	C 17	59.30.4100 C 10 U, 16 V, 1		
②	C 18	59.27.4470 C 47 U, 35 V, HL	1	
	C 19	59.30.1470 C 47 U, 3 V, TA	1	
②	C 20	59.04.7122 C 1.2 N, 5%, 25 V, PS	1	
③	C 21	59.04.7122 C 1.2 N, 1		
③	C 22	59.04.7662 C 6.8 N, 5%, 63 V, 1		
③	C 23	59.31.6224 C .22 U, 10%, 100 V, MPFET	1	
③	C 24	59.04.7122 C 1.2 N, 5%, 25 V, PS	1	
③	C 25	59.04.7122 C 1.2 N, 1		
③	C 26	59.04.7662 C 6.8 N, 5%, 63 V, 1		
③	C 27	59.31.6224 C .22 U, 10%, 100 V, MPFET	1	
	C 28	59.31.9104 C 0.1 U, 160 V, 1		
②	C 29	59.32.0101 C 100 F, 20%, 500 V, KBR	1	
②	C 30	59.27.4470 C 47 U, 50%, 35 V, HL	1	
	C 31	59.30.1101 C 100 U, 3 V, TA	1	
	C 32	59.32.0220 C 22 F, 20%, 500 V, KBR	1	
	C 33	59.25.4102 C 1.0 M, 50%, 18 V, BL	1	
	C 34	59.25.4102 C 1.0 M, 1		
⑤	C 35	59.25.4102 C 1.0 M, 1		

Aenderungen	① 5.9.72	② 19.3.73	③ 30.4.75	④ 23.6.75	⑤ 7.4.76
STUDER Positionsliste	① 8.3.76	②	③	④	⑤
REGENSDORF ZÜRICH	Reproduce Amplifier				
Kopie für	Ersatz für	Ersatz durch			1.080.986.00

Pos.	Bauteil No.	Bezeichnung	Stk	Bemerkung
②	C 36	59.32.0221 C 220 P, 20% 500V KBR	1	
②	C 37	59.32.0221 C 220 P, 1		
②	C 38	59.34.0339 C 3,3 P 10% 50V	1	
D 01	50.04.0125 D 1 N 4448,	ST	1	
D 02	50.04.0125 D		1	
HC 01	1.010.101.50 HC A 101, NP 4 DR		1	
I, 01	1.022.128.00 I, 9 M,	SCHKE	1	
I, 02	1.022.128.00 I,		1	
Q 01	50.03.0332 Q BC 179 B, F-Rauscherm, PNP		1	
Q 02	50.03.0442 Q BC 264 C, NPN		1	
Q 03	50.03.0306 Q BC 178 B, PNP		1	
Q 04	50.03.0306 Q		1	
Q 05	50.03.0409 Q BC 108 B, NPN		1	
Q 06	50.03.0306 Q BC 178 B, PNP		1	
Q 07	50.03.0409 Q BC 108 B, NPN		1	
Q 08	50.03.0306 Q BC 178 B, PNP		1	
Q 09	50.03.0409 Q BC 108 B, NPN		1	
Q 10	50.03.0306 Q BC 178 B, PNP		1	
Q 11	50.03.0316 Q BC 140-16, NPN		1	
Q 12	50.03.0315 Q BC 160-16, PNP		1	
R 01	57.41.4473 R 47 K, 5%, .12 W, CSCH		1	
R 02	57.41.4154 R 150 K, 1			
R 03	57.41.4102 R 1 K, 1			

Aenderungen	① 5.9.72	② 23.6.75	③ 10.6.76	④ 7.7.76	⑤ 10.2.77
STUDER Positionsliste	① 4.4.76	②	③	④	⑤
REGENSDORF ZÜRICH	Reproduce Amplifier				
Kopie für	Ersatz für	Ersatz durch			1.080.986.00

Pos.	Bauteil No.	Bezeichnung	Stk	Bemerkung
R 04	57.41.4153 R 15 K, 5%, .12 W, CSCH		1	
R 05	57.39.3900 R 390 , 1%, .33 M, NP		1	
R 06	57.41.4473 R 47 K, 5%, .12 W, CSCH		1	
R 07	57.41.4394 R 390 K, 1			
R 08	57.39.3900 R 390 , 1%, .33 M, NP		1	
R 09	57.39.6800 R 680 , 1			
R 10	57.39.6800 R 680 , 1			
R 11	57.41.4122 R 1.2 K, 5%, .12 W, CSCH		1	
R 12	57.41.4102 R 1.0 K, 1			
R 13	57.41.4472 R 4.7 K, 1			
R 14	57.41.4102 R 1.0 K, 1			
R 15	57.41.4681 R 680 , 1			
R 16	57.41.4470 R 47 , 1			
R 17	57.41.4103 R 10 K, 1			
R 18	58.03.0252 R 2.5 K, 10%, .5 W, PCBCH		1	
R 19	57.41.4103 R 10 K, 5%, .12 W, CSCH		1	
R 20	57.41.4152 R 1.5 K, 1			
R 21	57.41.4391 R 390 , 1			
R 22	57.41.4274 R 270 K, 1			
R 23	57.11.4103 R 10 K, 1			
R 24	57.11.4105 R 1.0 M, 1			
R 25	57.41.4470 R 47 , 1			
R 26	57.41.4470 R 47 , 1			
R 27	57.41.4392 R 3.3 K, 1			
R 28	57.41.4392 R 3.3 K, 1			
R 29	57.41.4101 R 100 , 1			
R 30	58.03.3502 R 5 K, 10%, .5 W, PCMA		1	
R 31	57.41.4331 R 330 , 5%, .12 W, CSCH		1	
R 32	57.41.4562 R 5.6 K, 1			
R 33	57.41.4472 R 4.7 K, 1			
R 34	58.03.0252 R 2.5 K, 10%, .5 W, PCBCH		1	
R 35	57.41.4331 R 330 , 5%, .12 W, CSCH		1	
R 36	57.41.4331 R 330 , 1			
R 37	57.41.4101 R 100 , 1			
R 38	58.03.3502 R 5 K, 10%, .5 W, PCMA		1	

Aenderungen	①	②	③ 10.6.76	④ 7.7.76	⑤ 10.2.77
STUDER Positionsliste	① 4.4.76	②	③	④	⑤
REGENSDORF ZÜRICH	Reproduce Amplifier				
Kopie für	Ersatz für	Ersatz durch			1.080.986.00

Pos.	Bauteil No.	Bezeichnung	Stk	Bemerkung
R 39	57.41.4331 R 330 , 5%, .12 W, CSCH		1	
R 40	57.41.4562 R 5.6 K, 1			
R 41	57.41.4472 R 4.7 K, 1			
R 42	58.03.0252 R 2.5 K, 10%, .5 W, PCBCH		1	
R 43	57.41.4331 R 330 , 5%, .12 W, CSCH		1	
R 44	58.03.3503 R 50 K, 10%, .5 W, PCMA		1	
R 45	57.41.4331 R 330 , 5%, .12 W, CSCH		1	
R 46	58.03.3503 R 50 K, 10%, .5 W, PCMA		1	
R 47	57.41.4101 R 100 , 5%, .12 W, CSCH		1	
R 48				
R 49				
R 50	57.41.4152 R 1.5 K, 1			
R 51	57.41.4470 R 47 , 1			
R 52	57.41.4154 R 150 K, 1			
R 53	57.41.4104 R 100 K, 1			
R 54	57.41.4471 R 470 , 1			
R 55	57.41.4472 R 4.7 K, 1			
R 56	57.41.4181 R 180 , 1			
R 57	57.41.4102 R 1.0 K, 1			
R 58	57.41.4022 R 0.2 K, 1			
R 59	57.41.4102 R 1.0 K, 1			
R 60	57.41.4470 R 47 , 1			
R 61	57.41.4391 R 390 , 1			
R 62	57.41.4102 R 1.0 K, 1			
R 63	57.12.4479 R 4.7 , .33 M, 1			
R 64	57.12.4479 R 4.7 , 1			
R 65	57.12.4479 R 4.7 , 1			
R 66	57.12.4479 R 4.7 , 1			
R 67	57.41.4102 R 1.0 K, .12 W, 1			

Aenderungen	①	②	③ 10.6.76	④ 7.7.76	⑤ 10.2.77
STUDER Positionsliste	① 4.4.76	②	③	④	⑤
REGENSDORF ZÜRICH	Reproduce Amplifier				
Kopie für	Ersatz für	Ersatz durch			1.080.986.00

RECORD AMPLIFIER 1.080.982

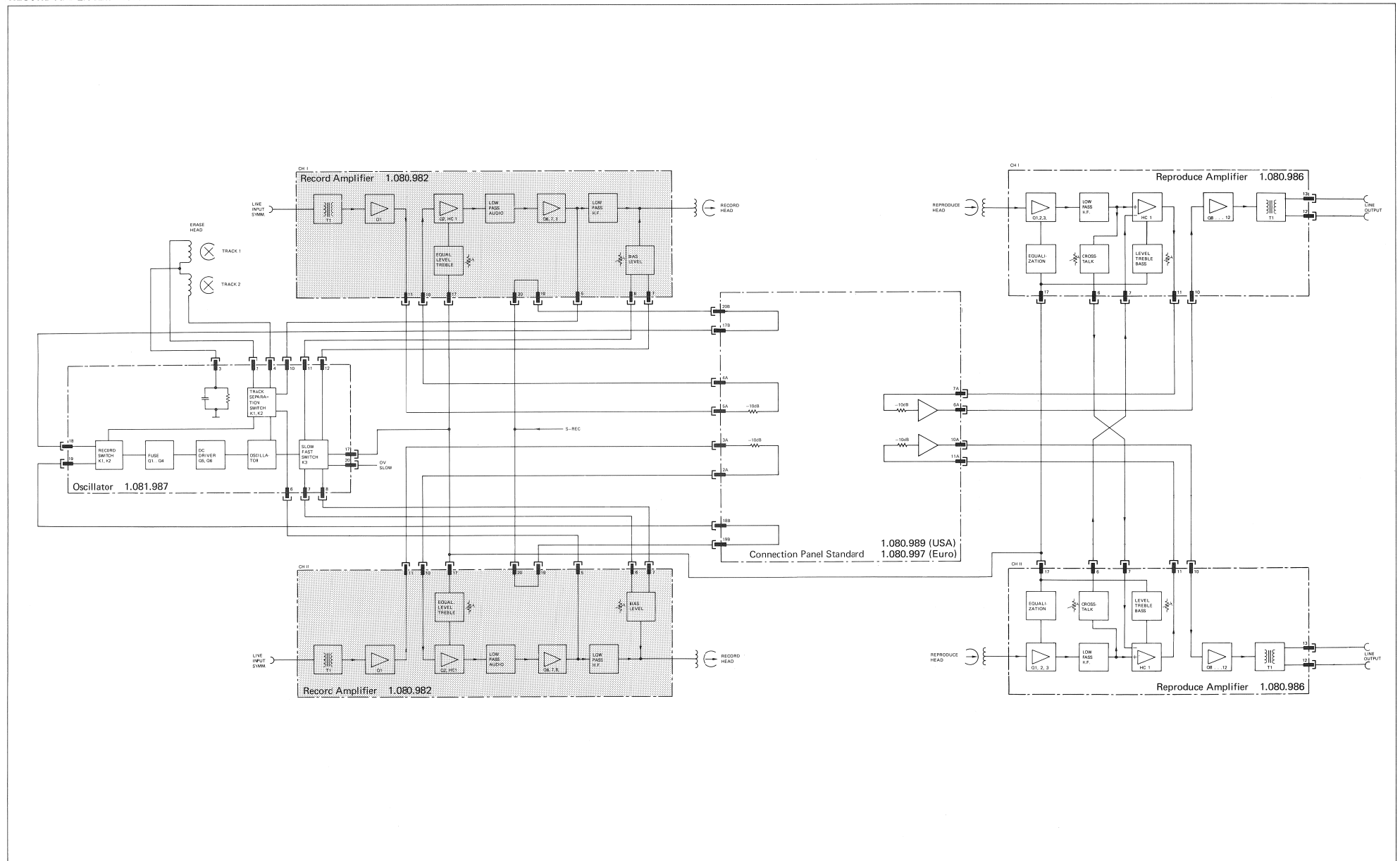

RECORD AMPLIFIER 1.080.982

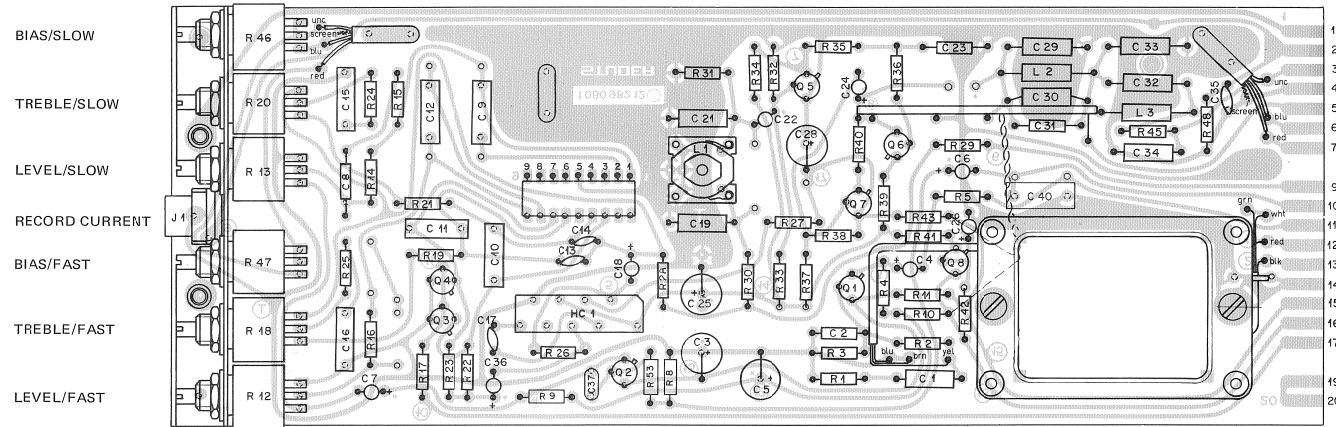

RECORD AMPLIFIER 1.080.982

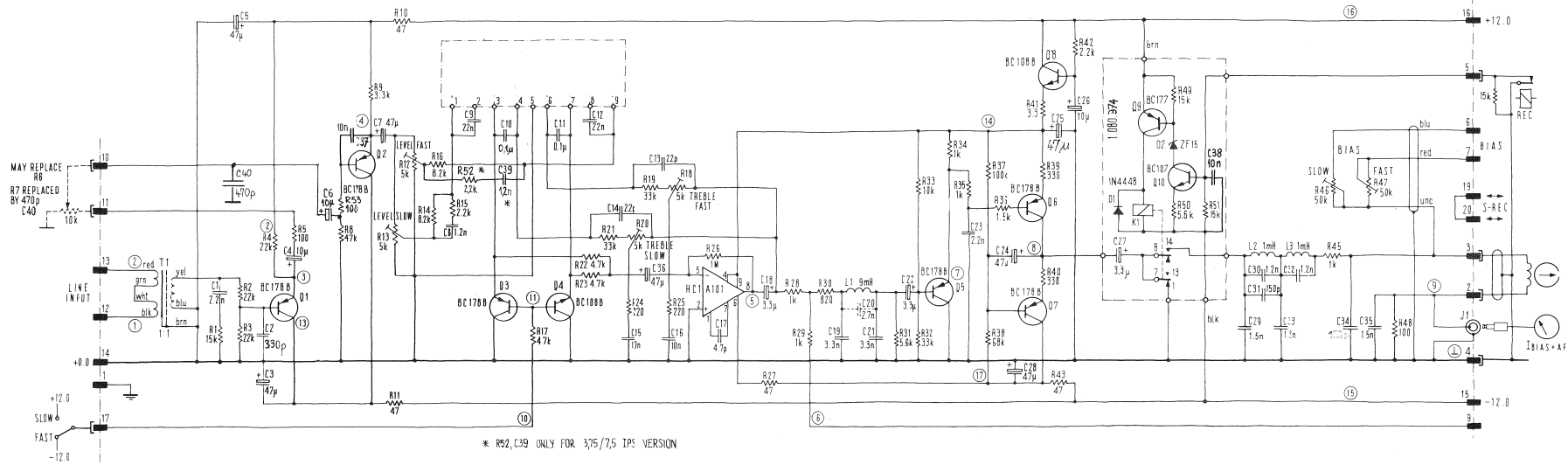
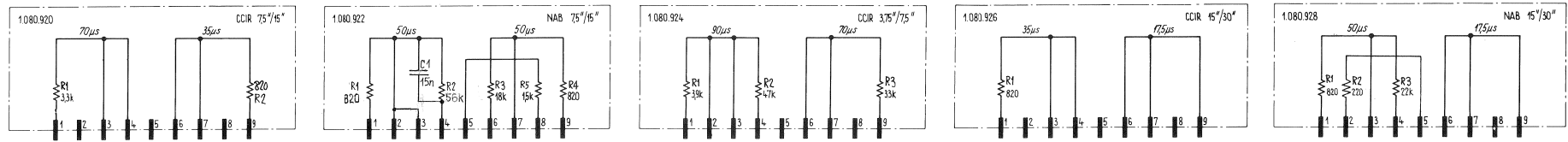

Input 1500 mV, 1 kHz Position "FAST"

TEST POINTS	1	2	3	4	5	6	7	8	9	10	11	12	13	14	15	16	17
mV ~	1500	750	225	430	340	270	820	70	—	—	—	—	—	—	—	—	—
V =	—	+0.8	+1	-0.5	—	+9.2	-0.5	—	-12	-0.7	+11.6	-11.6	+11.2	-12	+12	-11.6	—

AC-voltmeter, min. 100 kΩ
DC-voltmeter, min. 40 kΩ/V

RECORD AMPLIFIER 1.080.982

POS NO	PART NO	VALUE	SPECIFICATIONS	EQUIVALENT	MFR
C 04	59.04.7222	220F			
C 02	59.04.6281	330uF			
C 03	59.27.4470	47uF			
C 04	59.30.4500	10uF			
C 05	59.27.4470	47uF			
C 06	59.30.4500	10uF			
C 07	59.30.4500	10uF			
C 08	59.04.8422	1.2mC			
C 09	59.34.7222	220F			
C 10	59.30.4500	10uF			
C 11	59.36.6104	100uF			
C 12	59.31.7222	220F			
C 13	59.32.0220	220uF			
C 14	59.32.0220	220uF			
C 15	59.34.7104	10uF			
C 16	59.34.8104	10uF			
C 17	59.36.0470	4.7uF			
C 18	59.30.4500	10uF			
C 19	59.04.7222	220F			
C 20	11001 8490041				
C 21	59.04.7222	220F			
C 22	59.30.6219	55uF			
C 23	59.04.7222	220F			
C 24	59.30.4500	10uF			
C 25	59.27.4470	47uF			
C 26	59.30.4500	10uF			
C 27	59.04.7222	220F			
C 28	59.27.4470	47uF			
C 29	59.32.1122	150uF			
C 30	59.04.7222	220F			
C 31	59.04.8104	10uF			
C 32	59.04.8104	10uF			
C 33	59.04.8104	10uF			
C 34	59.04.8104	10uF			
C 35	59.04.8104	10uF			
C 36	59.04.8104	10uF			
C 37	59.04.8104	10uF			
C 38	59.04.8104	10uF			
C 39	11001 8490041				
C 40	59.04.8104	10uF			

STUDER Record Amplifier 1.080.982 PAGE 1 of 2

⑩ 10.6.76
⑪ 10.5.75
⑫ 18.3.75
⑬ 15.9.75
⑭ 11.11.1977
⑮ 7.7.76

IND DATE NAME

POS NO	PART NO	VALUE	SPECIFICATIONS	EQUIVALENT	MFR
R 20	59.04.0502	5A			11n
R 21	59.41.4152	22A			
R 22	59.41.4152	4.7A			
R 23	59.41.4152	4.7A			
R 24	59.41.4152	220A			
R 25	59.41.4152	220A			
R 26	59.41.4152	47A			
R 27	59.41.4152	47A			
R 28	59.41.4152	4A			
R 29	59.41.4152	4A			
R 30	59.41.4152	220A			
R 31	59.41.4152	56A			
R 32	59.41.4152	7A			
R 33	59.41.4152	10A			
R 34	59.41.4152	4A			
R 35	59.41.4152	4A			
R 36	59.41.4152	4.6A			
R 37	59.41.4152	1000A			
R 38	59.41.4152	220A			
R 39	59.41.4152	220A			
R 40	59.41.4152	220A			
R 41	59.41.4152	220A			
R 42	59.41.4152	220A			
R 43	11001 8490041				
R 44	59.41.4152	4A			
R 45	59.41.4152	50A			
R 46	59.41.4152	100A			
R 47	59.41.4152	5A			
R 48	59.41.4152	5A			
R 49	59.41.4152	5A			
R 50	59.41.4152	5A			
R 51	59.41.4152	5A			
R 52	11001 8490041				
R 53	59.41.4152	100A			

STUDER Record Amplifier 1.080.982 PAGE 2 of 2

⑩ 10.6.76
⑪ 10.5.75
⑫ 18.3.75
⑬ 15.9.75
⑭ 11.11.1977
⑮ 7.7.76

IND DATE NAME

POS NO	PART NO	VALUE	SPECIFICATIONS	EQUIVALENT	MFR
HC 01	1.080.101.20	4.7uF			
R 01	56.02.4002	250V 25V			11001 8490041
L 01	1.080.101.00	5.1mH			
L 02	62.01.0112	1mH			
L 03	62.01.0112	1mH			
R 04	59.01.0204	2V 172R	DVP		
R 05	59.01.0204	2V 172R	DVP		
R 06	59.01.0204	2V 172R	DVP		
R 07	59.01.0409	2V 102R	WVW		
R 08	59.01.0204	2V 172R	DVP		
R 09	59.01.0204	2V 172R	DVP		
R 10	59.01.0204	2V 102R	WVW		
R 11	59.01.0204	2V 102R	WVW		
R 12	59.01.0204	2V 102R	WVW		
R 13	59.01.0204	2V 102R	WVW		
R 14	59.01.0204	2V 102R	WVW		
R 15	59.01.0204	2V 102R	WVW		
R 16	59.01.0204	2V 102R	WVW		
R 17	59.01.0204	2V 102R	WVW		
R 18	59.01.0204	2V 102R	WVW		
R 19	59.01.0204	2V 102R	WVW		
R 20	59.01.0204	2V 102R	WVW		
R 21	59.41.4152	5A			11n
R 22	59.41.4152	22A			
R 23	59.41.4152	22A			
R 24	59.41.4152	2.7A			
R 25	59.41.4152	100A			
R 26	11001 8490041				
R 27	59.41.4152	47A			
R 28	59.41.4152	2.7A			
R 29	59.41.4152	47A			
R 30	59.41.4152	47A			
R 31	59.41.4152	47A			
R 32	59.41.4152	5A			50V
R 33	59.41.4152	5A			50V
R 34	59.41.4152	2.2A			
R 35	59.41.4152	2.2A			
R 36	59.41.4152	1.2A			
R 37	59.41.4152	2.7A			
R 38	59.41.4152	5A			11n
R 39	59.41.4152	22A			

STUDER Record Amplifier 1.080.982 PAGE 3 of 3

⑩ 10.6.76
⑪ 10.5.75
⑫ 18.3.75
⑬ 15.9.75
⑭ 11.11.1977
⑮ 7.7.76

IND DATE NAME

OSCILLATOR STEREO 1.080.984

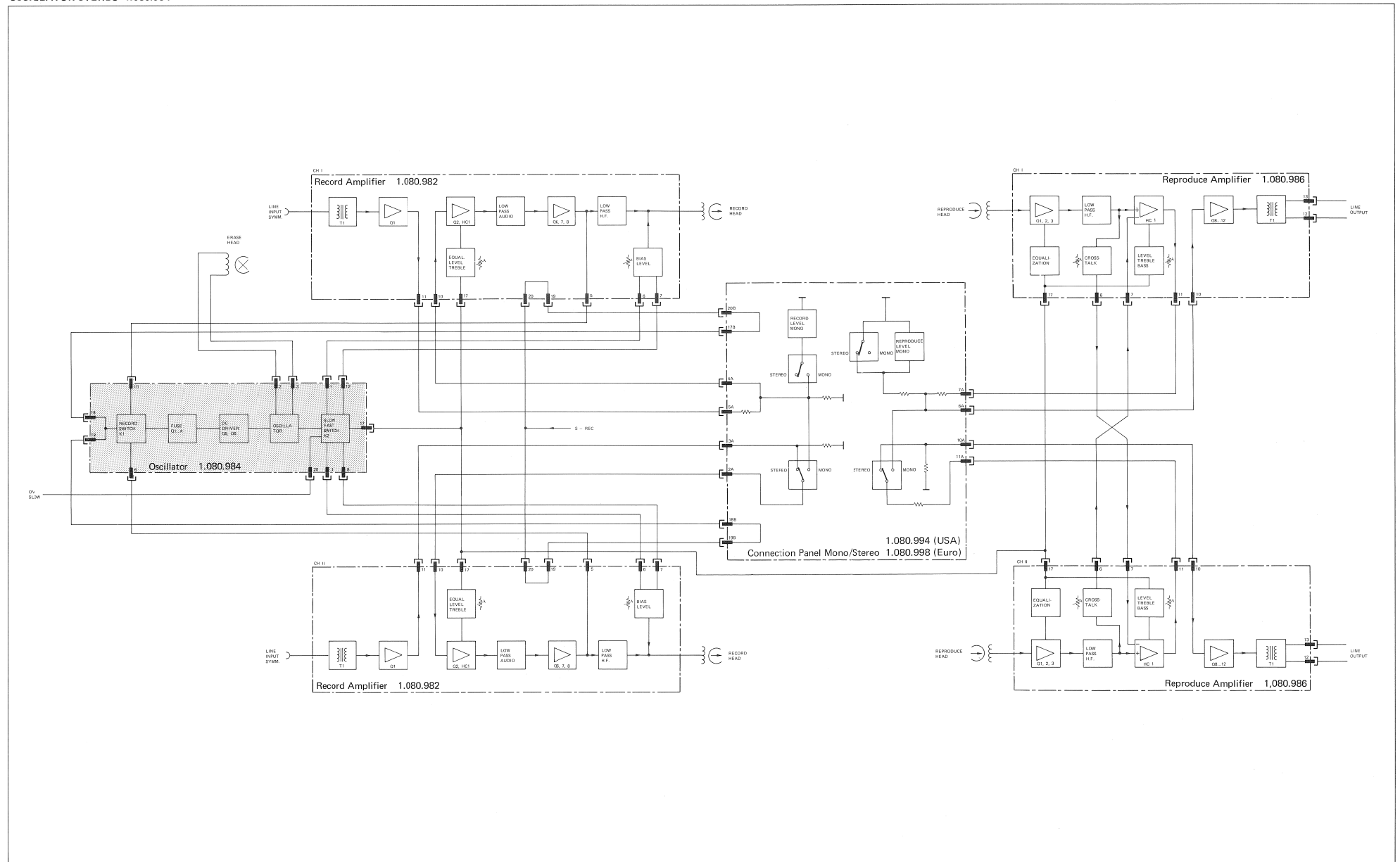

OSCILLATOR STEREO 1.080.984

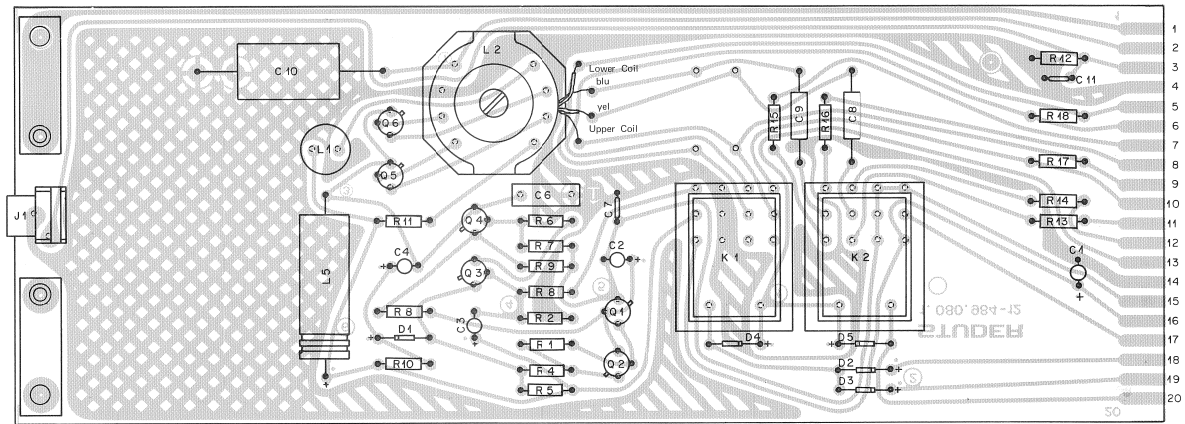

OSCILLATOR STEREO 1.080.984

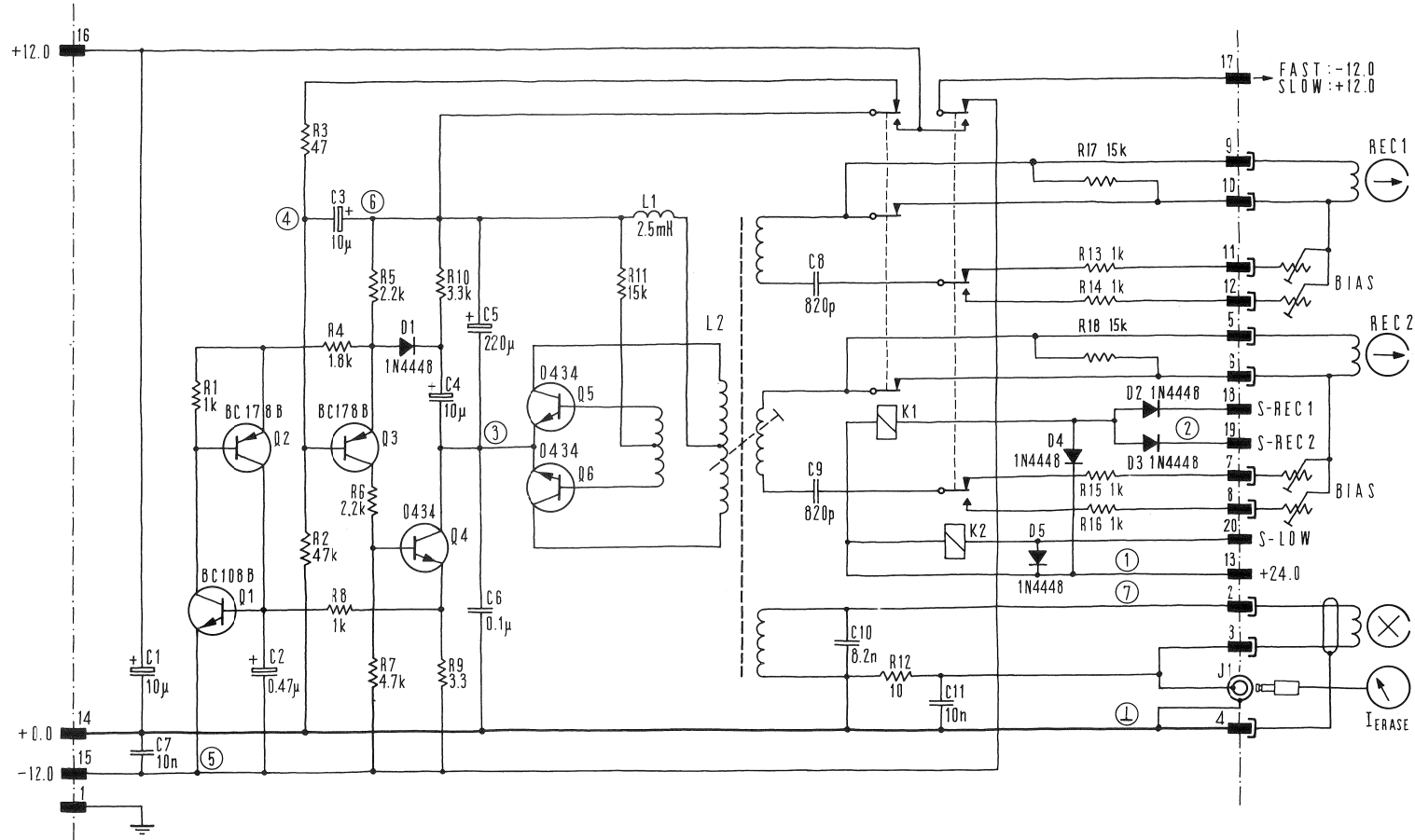

Position "FAST"

TEST POINTS	1	2	3	4	5	6	7	
V =	+ 24	-	-11.6	0.5	-12	+12	-	DC-voltmeter, min. 100 kΩ
					V~		96V	AC-voltmeter, min. 1 MΩ
					150 kHz			

OSCILLATOR STEREO 1.080.984

Pos	Bauteil No	Bezeichnung	Stk	Bemerkung
(4)	C 01	59.36.5100 C 10 U, 20 %, 35 V, TA	1	
	C 02	59.30.6478 C 47 U, 50%, 35 V, TA	1	
(4)	C 03	59.36.5100 C 10 U, 20 %, 35 V, TA	1	
(4)	C 04	59.36.5100 C 10 U, 20 %, 35 V, TA	1	
	C 05	59.25.5221 C 220 U, 100%, 35 V, BL	1	
	C 06	59.31.6104 C 0,1 U, 20%, 16C V, MPEPP	1	
	C 07	59.32.3103 C 10 N, 80%, 40 V, KRR	1	①
②	C 08	59.04.9821 C 820 P, 5%, 630 V, PS	1	
③	C 09	59.04.9821 C 820 P, 5%, 630 V, PS	1	
	C 10	59.04.9821 C 820 P, 5%, 630 V, PS	1	
	C 11	59.32.3103 C 10 N, 80%, 40 V, KRR	1	②
	D 01	50.04.0125 F 1N 4448, SI	1	
	D 02	50.04.0125 F 1N 4448, SI	1	
	D 03	50.04.0125 F 1N 4448, SI	1	
	D 04	50.04.0125 F 1N 4448, SI	1	
	D 05	50.04.0125 F 1N 4448, SI	1	
	I 01	54.02.0106 Jack-socket R 32408	1	
	K 01	56.04.0120 K 24V, .03 A, 4U, AU/AG	1	
	K 02	56.04.0120 K 24V, .03 A, 4U, AU/AG	1	
④	L 01	62.02.2122 HF-Drossel	1	
	L 02	1.022.130.00 Oszillatortrepule	1	

Aenderungen	① 10.5.73	② 17.3.75	③ 22.9.75	④ 12.12.78	⑤
STUDEF	Positionsliste				Erstellt: 10.0.72 Bz
REGENSDORF	Oszillator Mono/Stereo				Gespr: 26.9.72 PZ
ZÜRICH					Blatt: 1 Blatt: 2
Kopie für:	Ersatz für:	1.080.984.00			
	Ersatz durch:				

Pos	Bauteil No	Bezeichnung	Stk	Bemerkung
	Q 01	50.03.0409 Q BC 10B B, NPN	1	
	Q 02	50.03.0306 Q BC 17B B, PNP	1	
	Q 03	50.03.0306 Q BC 17B B, PNP	1	
	Q 04	50.03.0434 Q ATRE 0434, NPN	1	
	Q 05	50.03.0434 Q ATRE 0434, NPN	1	
	Q 06	50.03.0434 Q ATRE 0434, NPN	1	
	R 01	57.41.4102 R 1,0 K, 5%, .12 W, OSCH	1	
	R 02	57.41.4473 R 47 K, ,	1	
	R 03	57.41.4470 R 47 ,	1	
	R 04	57.41.4182 R 1,0 K, ,	1	
	R 05	57.41.4222 R 2,2 K, ,	1	
	R 06	57.41.4222 R 2,2 K, ,	1	
	R 07	57.41.4472 R 47 K, ,	1	
	R 08	57.41.4102 R 1,0 K, ,	1	
	R 09	57.41.4339 R 3,3 ,	1	
	R 10	57.41.4332 R 3,3 K, ,	1	
	R 11	57.41.4153 R 15 K, ,	1	
	R 12	57.41.4100 R 10 ,	1	
	R 13	57.41.4102 R 1,0 K, ,	1	
	R 14	57.41.4102 R 1,0 K, ,	1	
	R 15	57.41.4102 R 1,0 K, ,	1	
	R 16	57.41.4102 R 1,0 K, ,	1	
①	R 17	57.02.5153 R 15 K, 10%, .25 W, CM	1	
①	R 18	57.02.5153 R 15 K, 10%, .25 W, CM	1	

Aenderungen	① 10.5.73	② 17.3.75	③ 22.9.75	④ 12.12.78	⑤
STUDEF	Positionsliste				Erstellt: 10.0.72 Bz
REGENSDORF	Oszillator Mono/Stereo				Gespr: 26.9.72 PZ
ZÜRICH					Blatt: 2 Blatt: 2
Kopie für:	Ersatz für:	1.080.984.00			
	Ersatz durch:				

OSCILLATOR 2TRACK 1.081.987

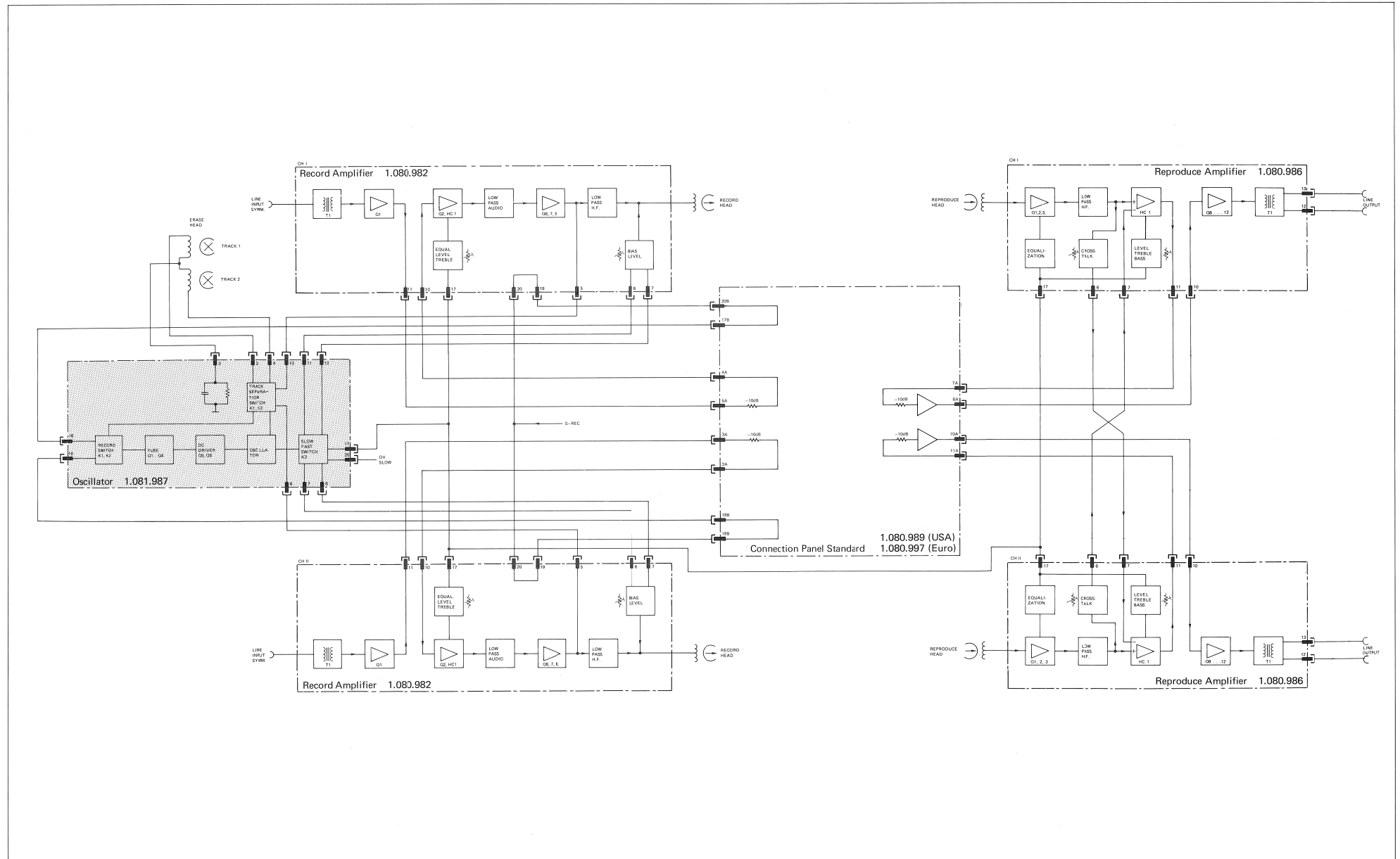

OSCILLATOR 2TRACK 1.081.987

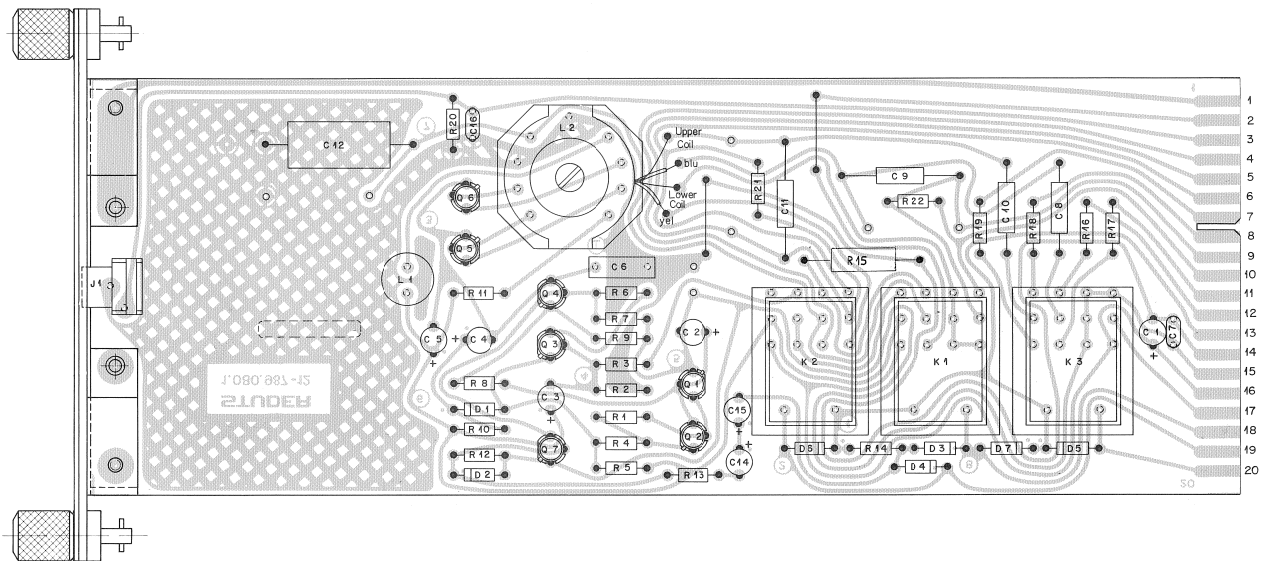

OSCILLATOR 2 TRACK 1.081.987

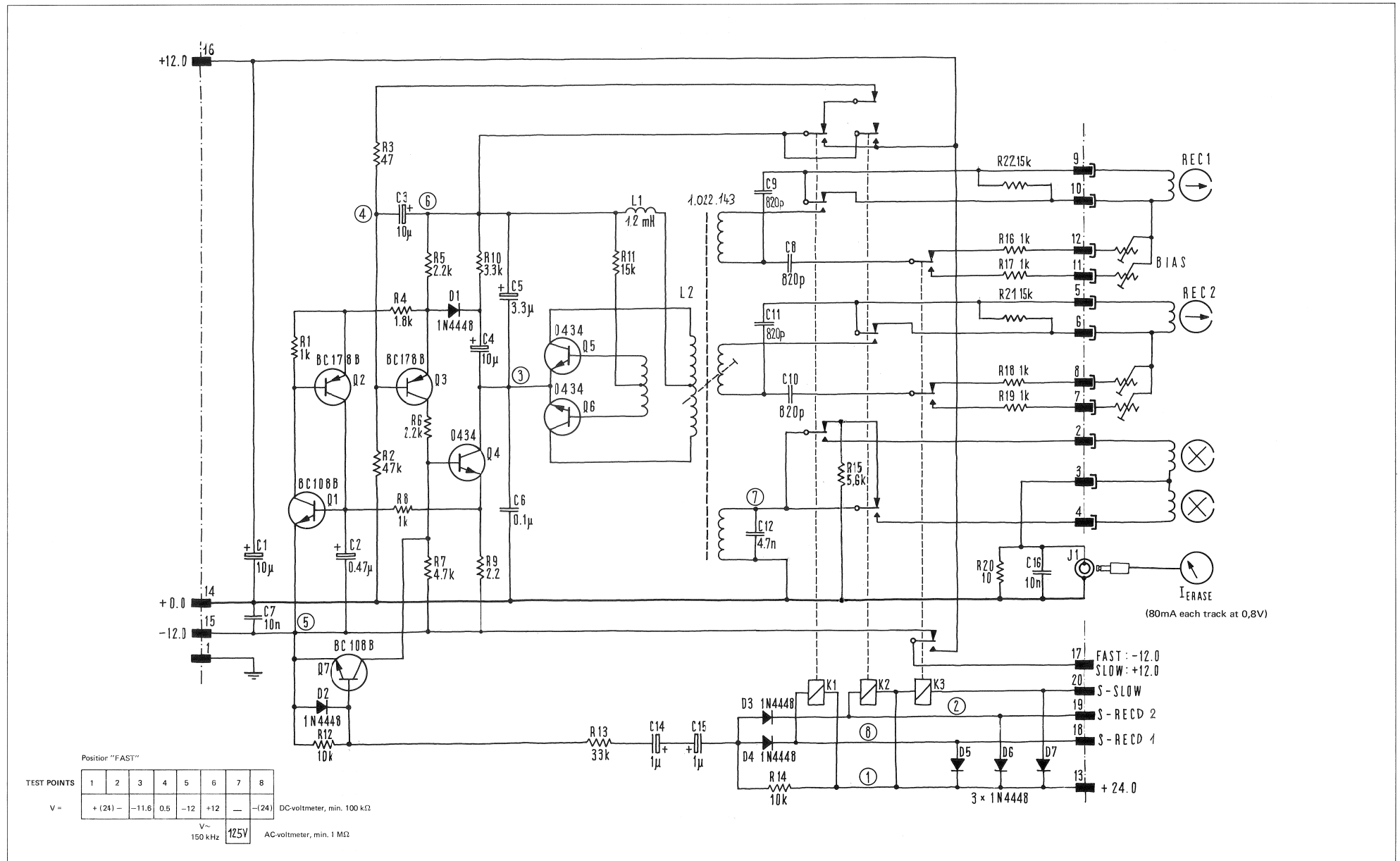

OSCILLATOR 2TRACK 1.081.987

IND	POS NO	PART NO	VALUE	SPECIFICATIONS/EQUIVALENT	MFR
C 01	59.30.7100	10pF		16V	
C 02	59.30.4478	0.02pF			
C 03	59.30.7100	10pF		25V	
C 04	59.30.7100	10pF		25V	
C 05	59.30.6339	33pF		25V	
C 06	59.31.4104	0.1uF	20%		
C 07	59.32.1103	10nF			
C 08	59.04.9821	820pF	5%	630V	
C 09	59.04.9821	820pF	5%	630V	
C 10	59.04.9821	820pF	5%	630V	
C 11	59.04.9821	820pF	5%	630V	
C 12	59.04.9872	4.7nF	5%	630V	
C 13	no t. used				
C 14	59.30.6109	1uF		25V	
C 15	59.30.6109	1uF		25V	
C 16	59.32.1103	10nF			
D 01	50.04.0125	1N4448			P.Tn
D 02	50.04.0125	1N4448			P.Tn
D 03	50.04.0125	1N4448			P.Tn
D 04	50.04.0125	1N4448			P.Tn
D 05	50.04.0125	1N4448			P.Tn
D 06	50.04.0125	1N4448			P.Tn
D 07	50.04.0125	1N4448			P.Tn
J 01	54.02.0106	P-32408		Sub Miniature Jack Socket	R

IND	DATE	NAME			
①			D = Philips		
②			Ta = Transtron		
③			Z = Receptor Instruments LTD		
④					
⑤	11.7.79	Brückegger			
STUDER			Oscillator	2-Track	1.081.987 PAGE 1 OF 2

IND	POS NO	PART NO	VALUE	SPECIFICATIONS/EQUIVALENT	MFR
R 01	57.41.4102	R2 -4	24V	50.0 Au/Ag	1TT
R 02	57.41.4102	R2 -4	24V	50.0 Au/Ag	1TT
R 03	57.41.4102	R2 -4	24V	50.0 Au/Ag	1TT
L 01	62.02.2122	12mH	5%		
L 02	1.022.145				ST
Q 01	50.03.0409	BC 107B			RS.MJ
Q 02	50.03.0406	BC 177B			P.S
Q 03	50.03.0406	BC 177B			P.S
Q 04	50.03.0414	BF814			SOS
Q 05	50.03.0414	BF814			SOS
Q 06	50.03.0414	BF814			SOS
Q 07	50.03.0409	BC 107B			RS.MJ
R 01	57.41.4102	1kΩ	5%	0.25W	
R 02	57.41.4103	47kΩ	5%	0.25W	
R 03	57.41.4103	47kΩ	5%	0.25W	
R 04	57.41.4102	1kΩ	5%	0.25W	
R 05	57.41.4222	2.2kΩ	5%	0.25W	
R 06	57.41.4222	2.2kΩ	5%	0.25W	
R 07	57.41.4472	4.7kΩ	5%	0.25W	
R 08	57.41.4102	1kΩ	5%	0.25W	
R 09	57.41.4220	2.2kΩ	5%	0.25W	

IND	DATE	NAME			
①			ST = STUDER	SOS = SOS/Ates	
②			P = Philips		
③			S = Schmitt		
④			H = Motorola		
⑤	11.7.79	Brückegger	Z = Intermetall (ITT)		
STUDER			Oscillator	2-Track	1.081.987 PAGE 2 OF 2

IND	POS NO	PART NO	VALUE	SPECIFICATIONS/EQUIVALENT	MFR
R 10	57.41.4102	1kΩ	5%	0.25W	
R 11	57.41.4102	1kΩ	5%	0.25W	
R 12	57.41.4102	1kΩ	5%	0.25W	
R 13	57.41.4102	1kΩ	5%	0.25W	
R 14	57.41.4102	1kΩ	5%	0.25W	
R 15	57.41.4102	1kΩ	5%	0.25W	
R 16	57.41.4102	1kΩ	5%	0.25W	
R 17	57.41.4102	1kΩ	5%	0.25W	
R 18	57.41.4102	1kΩ	5%	0.25W	
R 19	57.41.4102	1kΩ	5%	0.25W	
R 20	57.41.4102	1kΩ	5%	0.25W	
R 21	57.02.5153	15kΩ	10%	0.25W	
R 22	57.02.5153	15kΩ	10%	0.25W	

IND	DATE	NAME			
①					
②					
③					
④					
⑤	11.7.79	Brückegger			
STUDER			Oscillator	2-Track	1.081.987 PAGE 3 OF 3

OSCILLATOR 4 CHANNEL 1.080.965

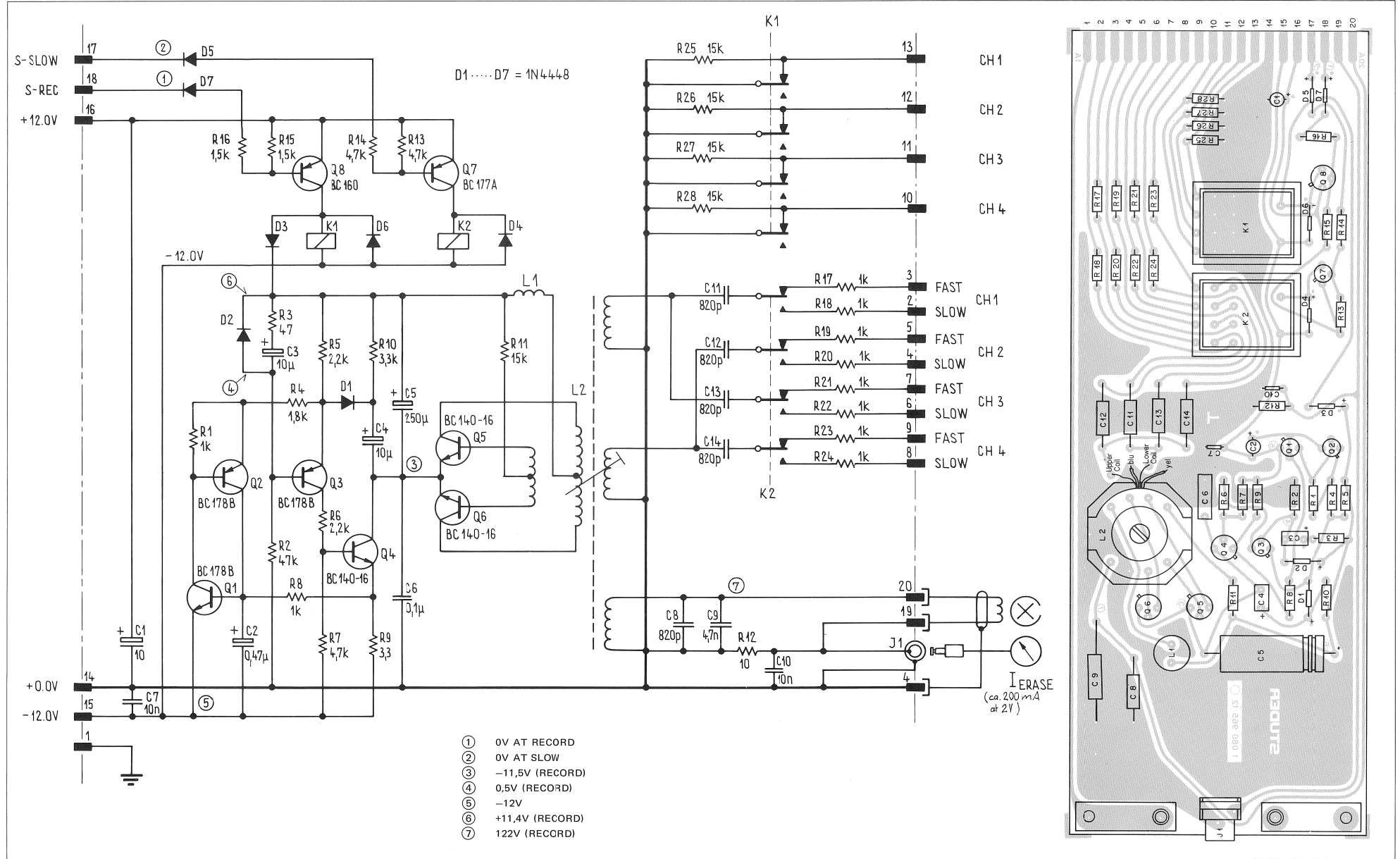

OSCILLATOR 4 CHANNEL 1.080.965

Pos.	Bauteil No.	Bezeichnung	Stk.	Bemerkung
C 01	59.30.6109	C 1.0 U.	TA	1
C 02	59.30.6478	C 0.47 U.	TA	1
C 03	59.36.5100	C 10 U.	35V TA	1
C 04	59.36.5100	C 10 U.	35V TA	1
C 05	59.25.5221	C 220 U.	100% 35 V. EL	1
C 05	59.31.4104	C 0.1 U.	20% 160 V. MRS	1
C 07	59.32.3103	C 10 N.	80% 40 V. KBR	1
C 08	59.04.9821	C 820 F.	5% 630 V. PS	1
C 09	59.04.9472	C 4.7 N.		1
C 10	59.32.3103	C 10 N.	80% 40 V KBR	1
C 11	59.04.9821	C 820 F.	5% 630 V PS	1
C 12	59.04.9821	C 820 F.		1
C 13	59.04.9821	C 820 F.		1
C 14	59.04.9821	C 820 F.		1
D 01	50.04.0125	D 1 N 4448	SI	1
D 02	50.04.0125	D 1 N 4448		1
D 03	50.04.0122	D 1 N 4001		1
D 04	50.04.0125	D 1 N 4448		1
D 05	50.04.0125	D 1 N 4448		1
D 05	50.04.0125	D 1 N 4448		1
D 07	50.04.0125	D 1 N 4448		1
K 01	56.04.0120	K 24 V = .03A. 4U. NU/AG		1
K 02	56.04.0120	K 24 V = .		1
L 01	62.02.2122	1.2 M		1
L 02	1.022.143.00	L. Oszillatorschaltung kompl.		1

Anderungen ① 17.2.75 ② 22.9.75 ③ 12.12.78 ④ ⑤

STUDER Positionsliste
 REGENSDORF ZÜRICH
 Erstellt: 15.8.73 ve
 Geprüft:
 Blatt: 1 Blätter: 3
 Kopie für: Ersetzt für: Ersetzt durch: 1.080.965

Pos.	Bauteil No.	Bezeichnung	Stk.	Bemerkung
Q 01	50.03.0409	Q BC 108 B	SI	1
Q 02	50.03.0306	Q BC 178 B		1
Q 03	50.03.0306	Q BC 178 B		1
Q 04	50.03.0316	Q BC 140 - 16		1
Q 05	50.03.0316	Q BC 140 - 16		1
Q 06	50.03.0316	Q BC 140 - 16		1
Q 07	50.03.0307	Q BC 177 A		1
Q 08	50.03.0315	Q BC 160 - 16		1
Q 09				
R 01	57.41.4102	R 1 k 5 % .12W C80H		1
R 02	57.41.4473	R 47 k		1
R 03	57.41.4470	R 47		1
R 04	57.41.4182	R 1.0 k		1
R 05	57.41.4222	R 2.2 k		1
R 06	57.41.4222	R 2.2 k		1
R 07	57.41.4472	R 4.7 k		1
R 08	57.41.4102	R 1 k		1
R 09	57.41.5222	R 2.2		1
R 10	57.41.4332	R 3.3 k		1
R 11	57.41.4822	R 8.2 k		1
R 12	57.41.4100	R 10		1
R 13	57.41.4472	R 4.7 k		1
R 14	57.41.4472	R 4.7 k		1
R 15	57.41.4152	R 1.5 k		1
R 16	57.41.4152	R 1.5 k		1
R 17	57.41.4102	R 1 k		1
R 18	57.41.4102	R 1 k		1
R 19	57.41.4102	R 1 k		1
R 20	57.41.4102	R 1 k		1
R 21	57.41.4102	R 1 k		1
R 22	57.41.4102	R 1 k		1
R 23	57.41.4102	R 1 k		1
R 24	57.41.4102	R 1 k		1
R 25	57.41.4153	R 15 k		1

Anderungen ① 17.2.75 ② ③ 12.12.78 ④ ⑤

STUDER Positionsliste
 REGENSDORF ZÜRICH
 Erstellt: 15.8.73 ve
 Geprüft:
 Blatt: 2 Blätter: 3
 Kopie für: Ersetzt für: Ersetzt durch: 1.080.965

Pos.	Bauteil No.	Bezeichnung	Stk.	Bemerkung
R 26	57.41.4153	R 15 k 5 % .12W C80H		1
R 27	57.41.4153	R 15 k		1
R 28	57.41.4153	R 15 k		1

Anderungen ① 17.2.75 ② ③ 12.12.78 ④ ⑤

STUDER Positionsliste
 REGENSDORF ZÜRICH
 Erstellt: 15.8.73 ve
 Geprüft:
 Blatt: 3 Blätter: 3
 Kopie für: Ersetzt für: Ersetzt durch: 1.080.965

PILOT TONE AMPLIFIER MK II 1.080.932

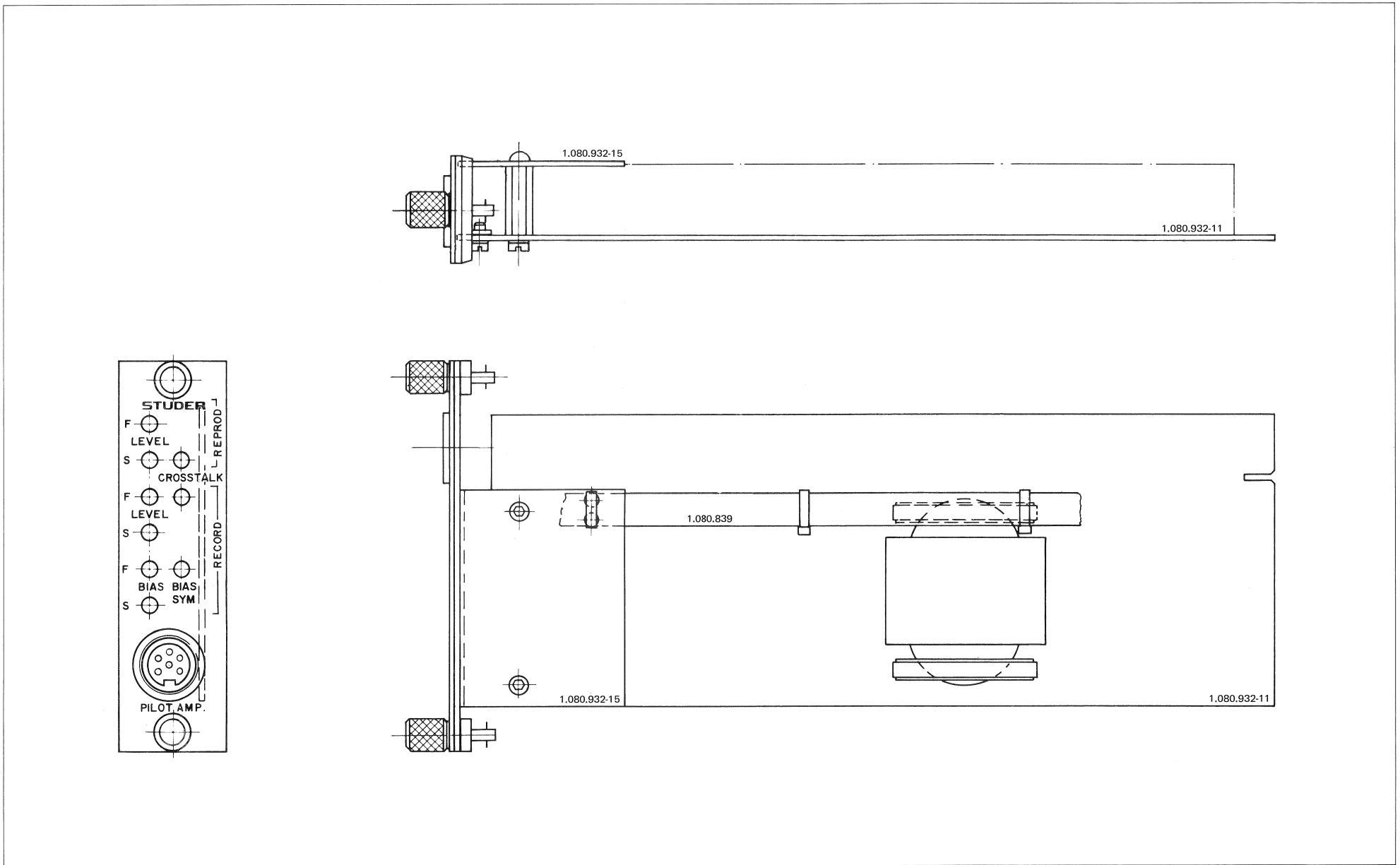

PILOT TONE AMPLIFIER MK II 1.080.932

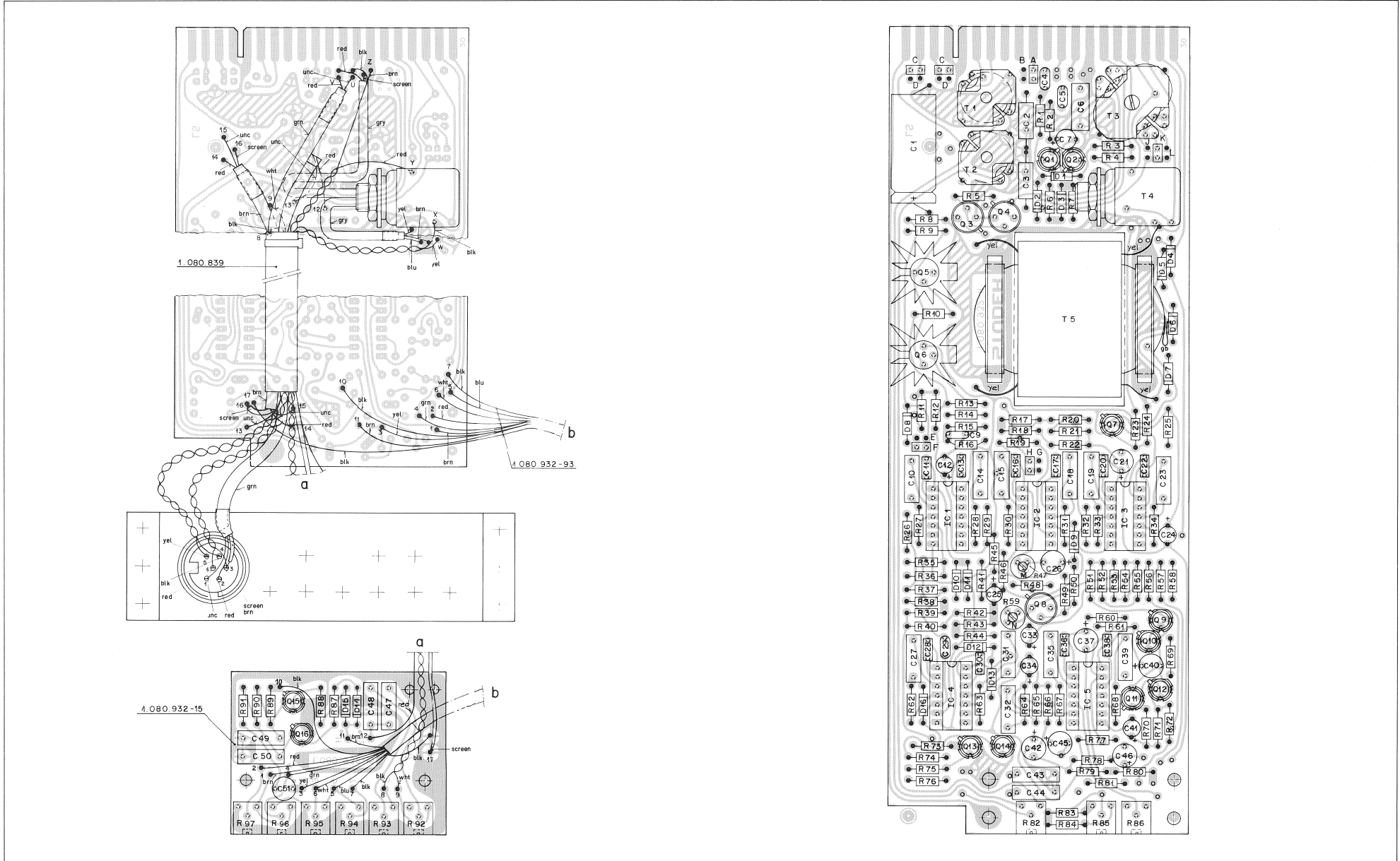

PILOT TONE AMPLIFIER MK II 1.080.932

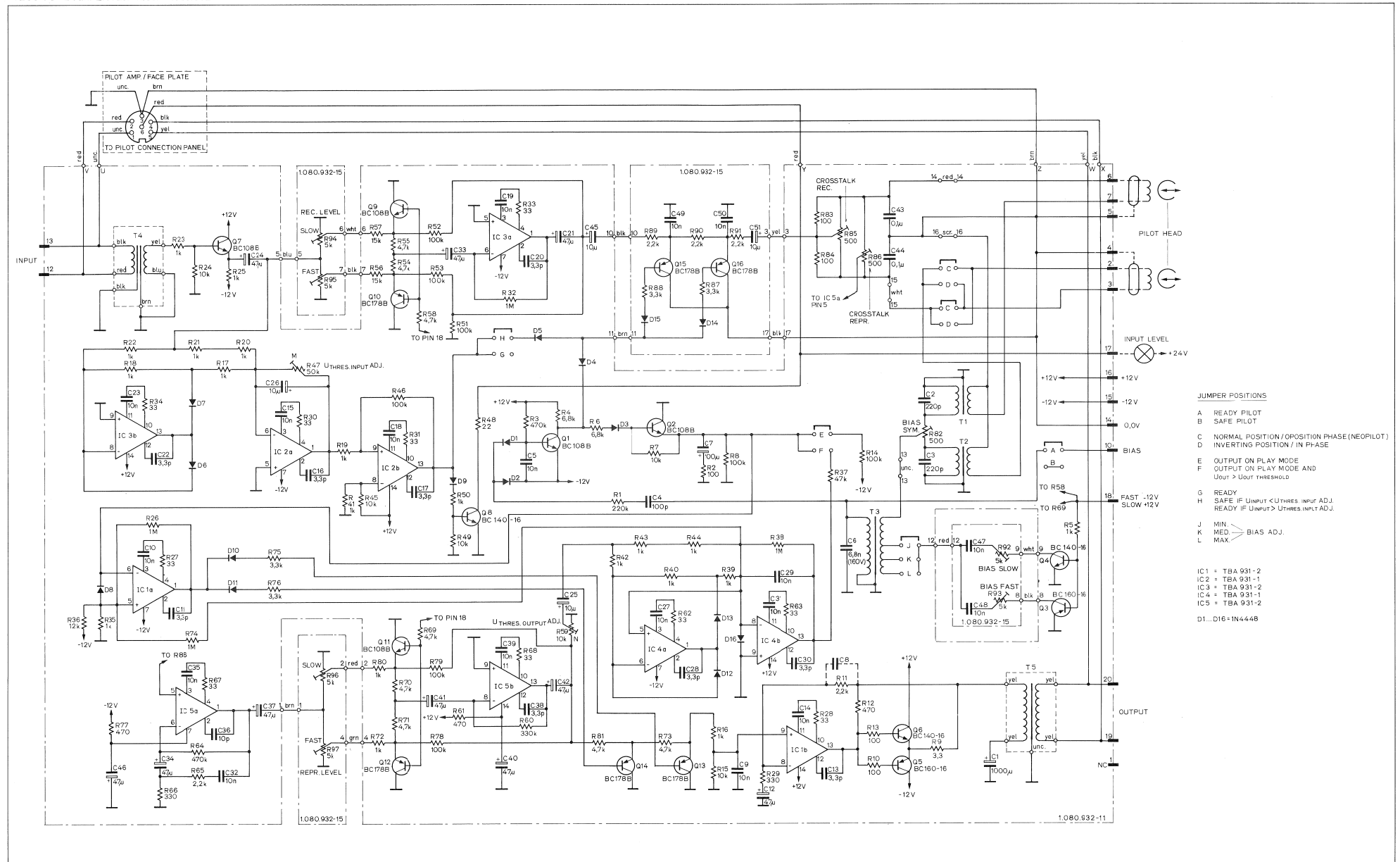

- JUMPER POSITIONS**
- A READY PILOT
 - B SAFE PILOT
 - C NORMAL POSITION / POSITION PHASE (NEOPILOT)
 - D INVERTING POSITION / IN PHASE
 - E OUTPUT ON PLAY MODE
 - F OUTPUT ON PLAY MODE AND
U_{out} > U_{thres}
 - G READY
 - H SAFE IF U_{input} < U_{thres} INPUT ADJ.
READY IF U_{input} > U_{thres} INPUT ADJ.
 - J MIN
 - L MED
 - K MAX
- IC 1 = TBA 931-2
 IC 2 = TBA 931-1
 IC 3 = TBA 931-2
 IC 4 = TBA 931-1
 IC 5 = TBA 931-2
 D1...D16 = 1N4448

PILOT TONE AMPLIFIER MK II 1.080.932

Table with 5 columns: Pos, Bauteil No, Bezeichnung, Stk, Bemerkung. Contains component list for the Pilot Tone Amplifier MK II 1.080.932, including resistors, capacitors, and transistors.

Administrative table with 4 columns: Änderungen, Positionsliste, Erstellen, and Kopie für. Includes 'STUDER REGENSDORF ZÜRICH' and 'Pilotton-Einschub MK 2'.

Table with 5 columns: Pos, Bauteil No, Bezeichnung, Stk, Bemerkung. Continuation of component list for the Pilot Tone Amplifier MK II 1.080.932.

Table with 5 columns: Pos, Bauteil No, Bezeichnung, Stk, Bemerkung. Continuation of component list for the Pilot Tone Amplifier MK II 1.080.932.

Administrative table with 4 columns: Änderungen, Positionsliste, Erstellen, and Kopie für. Includes 'STUDER REGENSDORF ZÜRICH' and 'Pilotton-Einschub MK 2'.

Table with 5 columns: Pos, Bauteil No, Bezeichnung, Stk, Bemerkung. Continuation of component list for the Pilot Tone Amplifier MK II 1.080.932.

Administrative table with 4 columns: Änderungen, Positionsliste, Erstellen, and Kopie für. Includes 'STUDER REGENSDORF ZÜRICH' and 'Pilotton-Einschub MK 2'.

Table with 5 columns: Pos, Bauteil No, Bezeichnung, Stk, Bemerkung. Continuation of component list for the Pilot Tone Amplifier MK II 1.080.932.

Table with 5 columns: Pos, Bauteil No, Bezeichnung, Stk, Bemerkung. Continuation of component list for the Pilot Tone Amplifier MK II 1.080.932.

Administrative table with 4 columns: Änderungen, Positionsliste, Erstellen, and Kopie für. Includes 'STUDER REGENSDORF ZÜRICH' and 'Pilotton-Einschub MK 2'.

Table with 5 columns: Pos, Bauteil No, Bezeichnung, Stk, Bemerkung. Continuation of component list for the Pilot Tone Amplifier MK II 1.080.932.

Administrative table with 4 columns: Änderungen, Positionsliste, Erstellen, and Kopie für. Includes 'STUDER REGENSDORF ZÜRICH' and 'Pilotton-Einschub MK 2'.

Table with 5 columns: Pos, Bauteil No, Bezeichnung, Stk, Bemerkung. Continuation of component list for the Pilot Tone Amplifier MK II 1.080.932.

Table with 5 columns: Pos, Bauteil No, Bezeichnung, Stk, Bemerkung. Continuation of component list for the Pilot Tone Amplifier MK II 1.080.932.

Administrative table with 4 columns: Änderungen, Positionsliste, Erstellen, and Kopie für. Includes 'STUDER REGENSDORF ZÜRICH' and 'Pilotton-Einschub MK 2'.

CONNECTION PANEL (STANDARD) USA 1.080.989 / EURO 1.080.997

USA 1.080.989

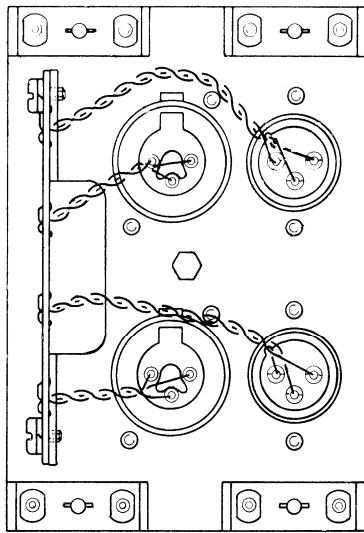
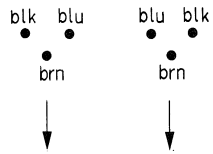

EURO 1.080.997

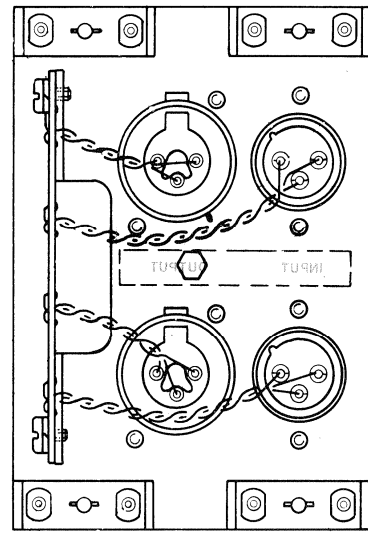
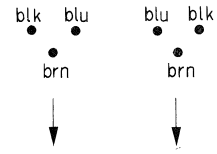

VIEW - A

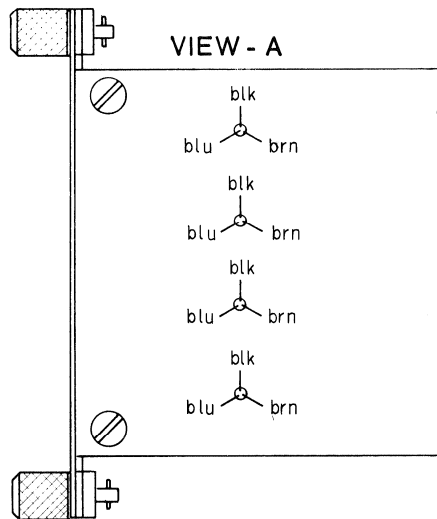

CONNECTION PANEL (STANDARD) USA 1.080.989 / EURO 1.080.997

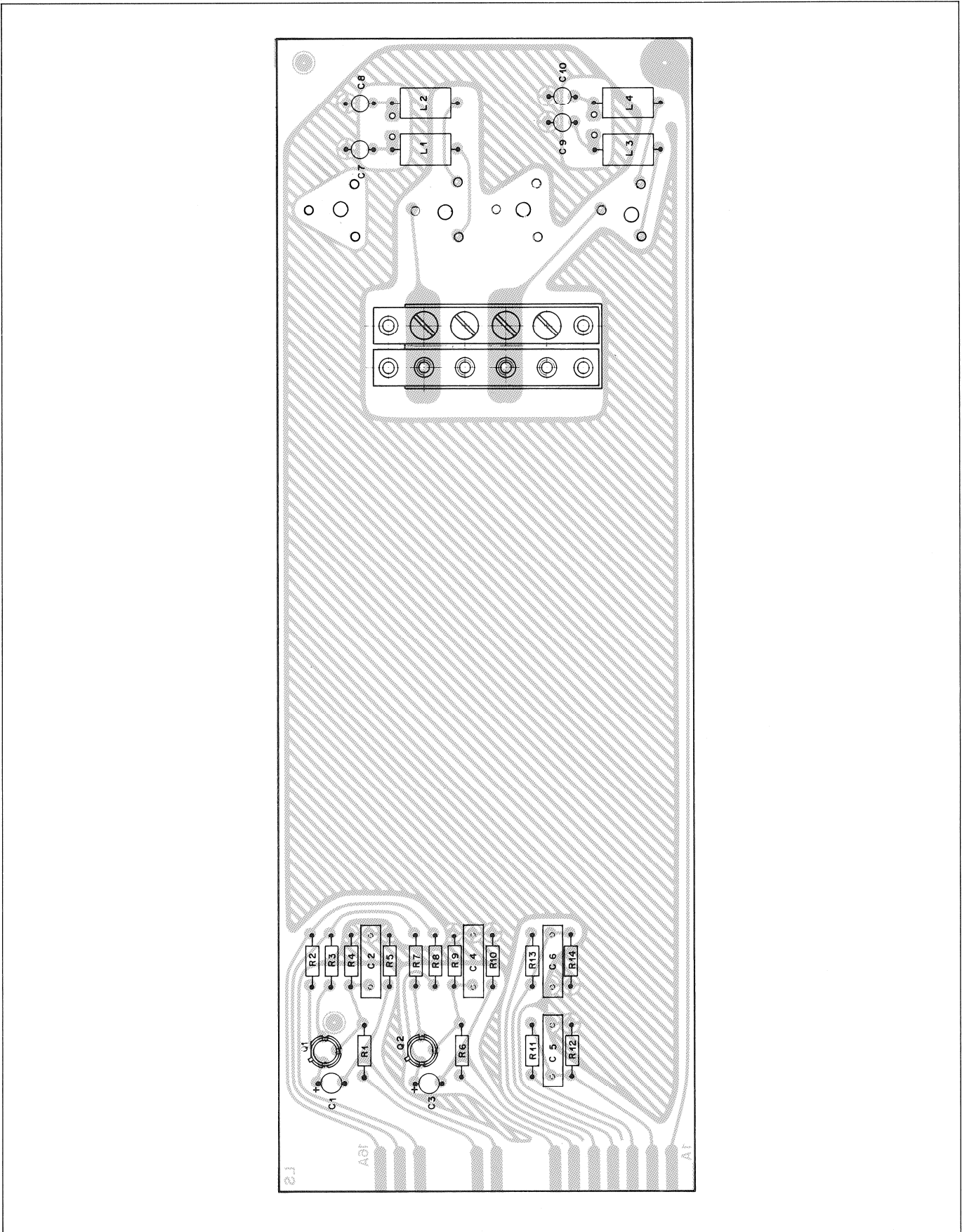

CONNECTION PANEL (STANDARD) USA 1.080.989 / EURO 1.080.997

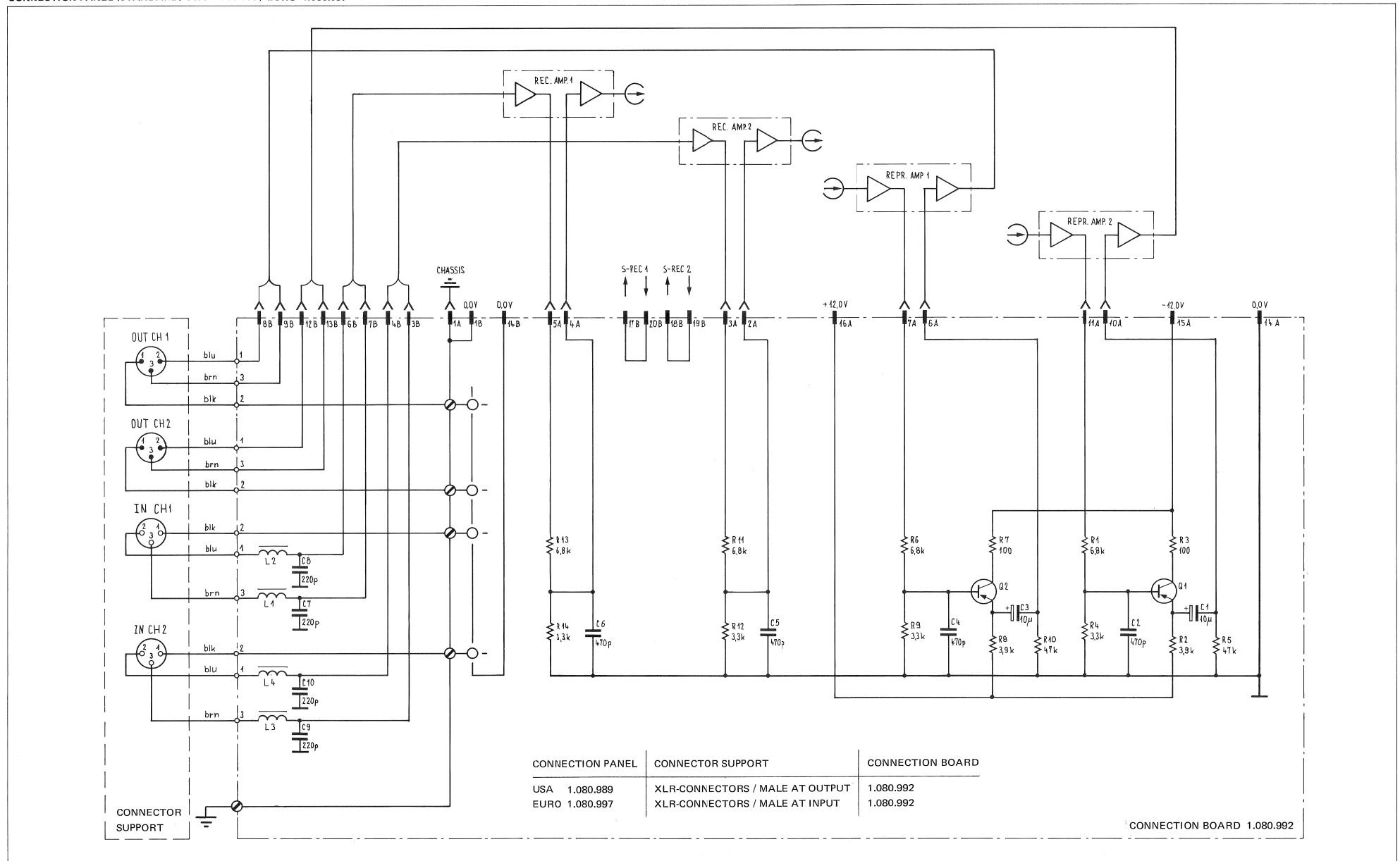

CONNECTION PANEL (STANDARD) USA 1.080.989 / EURO 1.080.997

Pos.	Bauteil No.	Bezeichnung	Stk.	Bemerkung
C 1	59.30.4900	C 400u	50%	400V TA
C 1	59.41.6474	C 470p	5%	400V FC
C 2	59.30.4900	C 400u	50%	400V TA
C 2	59.41.6474	C 470p	5%	400V FC
C 5	59.41.6474	C 470p	5%	400V FC
C 6	59.41.6474	C 470p	5%	400V FC
C 7	59.32.0221	C 220p	20%	500V MICA
C 8	59.32.0221	C 220p	20%	500V MICA
C 9	59.32.0221	C 220p	20%	500V MICA
C 10	59.32.0221	C 220p	20%	500V MICA

L 1	62.01.0115	Breitbanddrossel	1	
L 2	62.01.0115	Breitbanddrossel	1	
L 3	62.01.0115	Breitbanddrossel	1	
L 4	62.01.0115	Breitbanddrossel	1	

Q 1	50.03.0306	Q BC 170 B	PNP	1
Q 2	50.03.0306	Q BC 170 B	PNP	1

R 1	57.41.4602	R 6.8K	5%	25W CSCH
R 2	57.41.4332	R 3.3K	5%	25W CSCH
R 3	57.41.4501	R 400	5%	25W CSCH
R 4	57.41.4332	R 3.3K	5%	25W CSCH
R 5	57.41.4473	R 47K	5%	25W CSCH
R 6	57.41.4602	R 6.8K	5%	25W CSCH
R 7	57.41.4501	R 400	5%	25W CSCH

Aenderungen	①	②	③	④	⑤
STUDER	Positionsliste				Erstellt: 18.04.2010
REGENSDORF	Anschlussprint kompl.				Geprüft: H. P. 74
ZÜRICH					Blatt: 1
Kopie für:	Ersatz für:				Blätter: 2
	Ersetzt durch:				1.080.992

Pos.	Bauteil No.	Bezeichnung	Stk.	Bemerkung
R 6	57.41.4332	R 3.3K	5%	25W CSCH
R 9	57.41.4332	R 3.3K	5%	25W CSCH
R 10	57.41.4473	R 47K	5%	25W CSCH
R 11	57.41.4602	R 6.8K	5%	25W CSCH
R 12	57.41.4332	R 3.3K	5%	25W CSCH
R 13	57.41.4602	R 6.8K	5%	25W CSCH
R 14	57.41.4332	R 3.3K	5%	25W CSCH

Aenderungen	①	②	③	④	⑤
STUDER	Positionsliste				Erstellt: 18.04.2010
REGENSDORF	Anschlussprint kompl.				Geprüft: H. P. 74
ZÜRICH					Blatt: 2
Kopie für:	Ersatz für:				Blätter: 2
	Ersetzt durch:				1.080.992

CONNECTION PANEL (WITH MONO/STEREO SWITCH) USA 1.080.994 / EURO 1.080.998

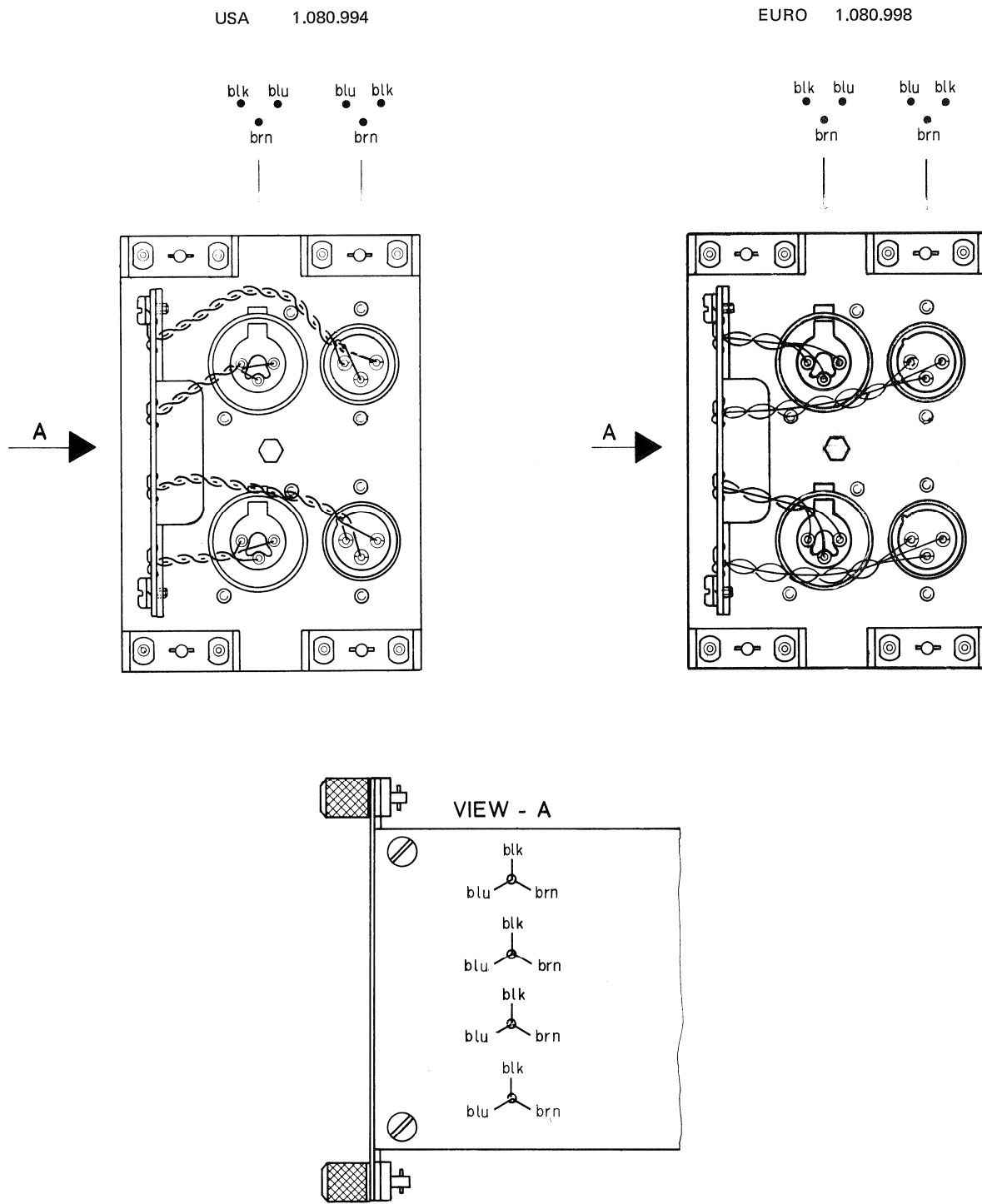

MONO/STEREO SWITCH 1.080.994

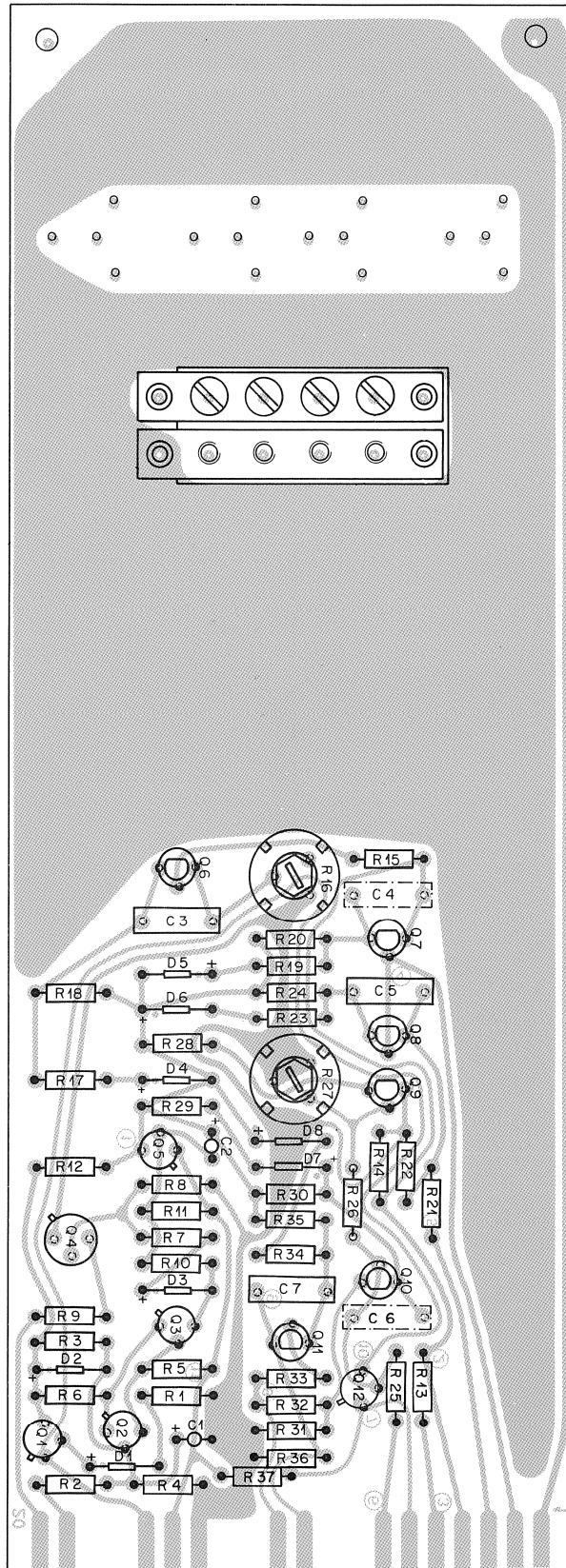

CONNECTION PANEL (WITH MONO/STEREO SWITCH) USA 1.080.994 / EURO 1.080.998

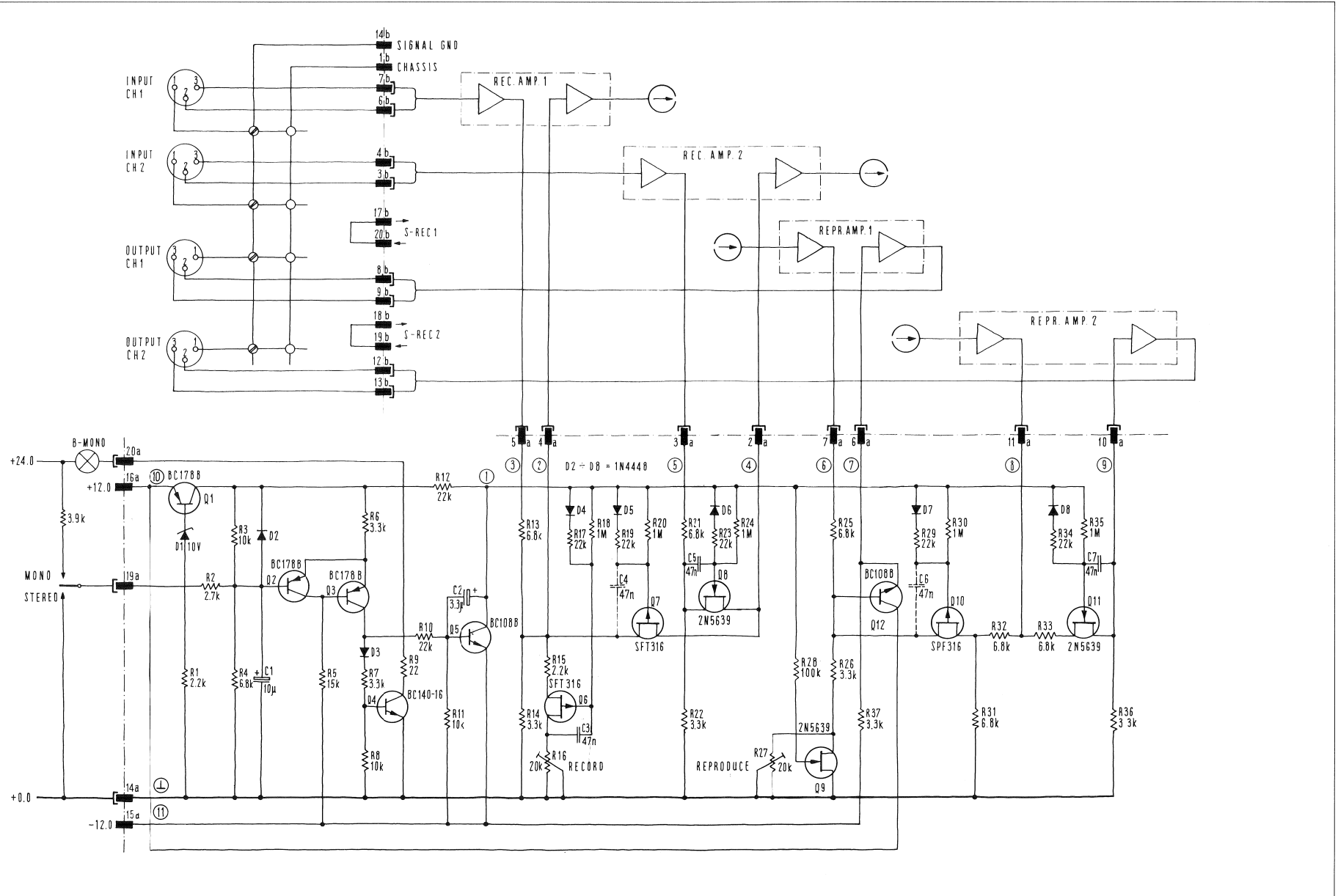

CONNECTION PANEL (WITH VU-METER PANEL CONNECTOR) USA 1.080.993/EURO 1.080.991

USA 1.080.993

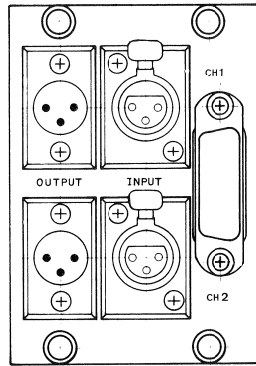

EURO 1.080.991

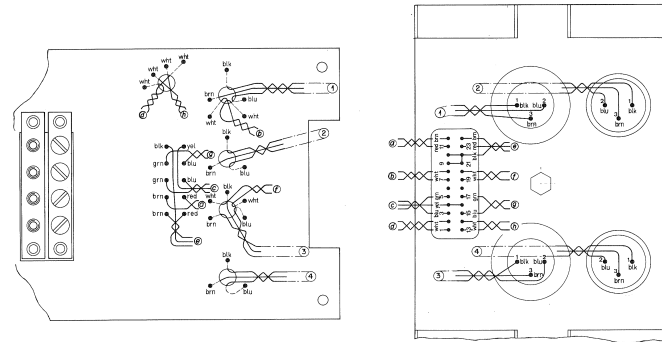
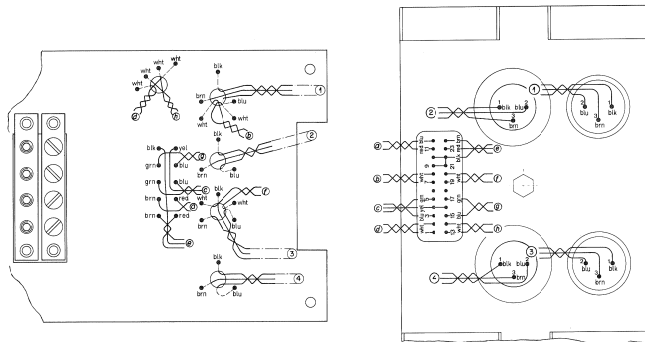
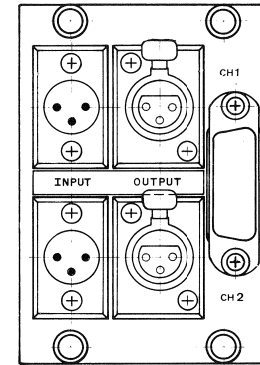

CONNECTION PANEL (WITH VU-METER PANEL CONNECTOR) USA 1.080.993/EURO 1.080.991

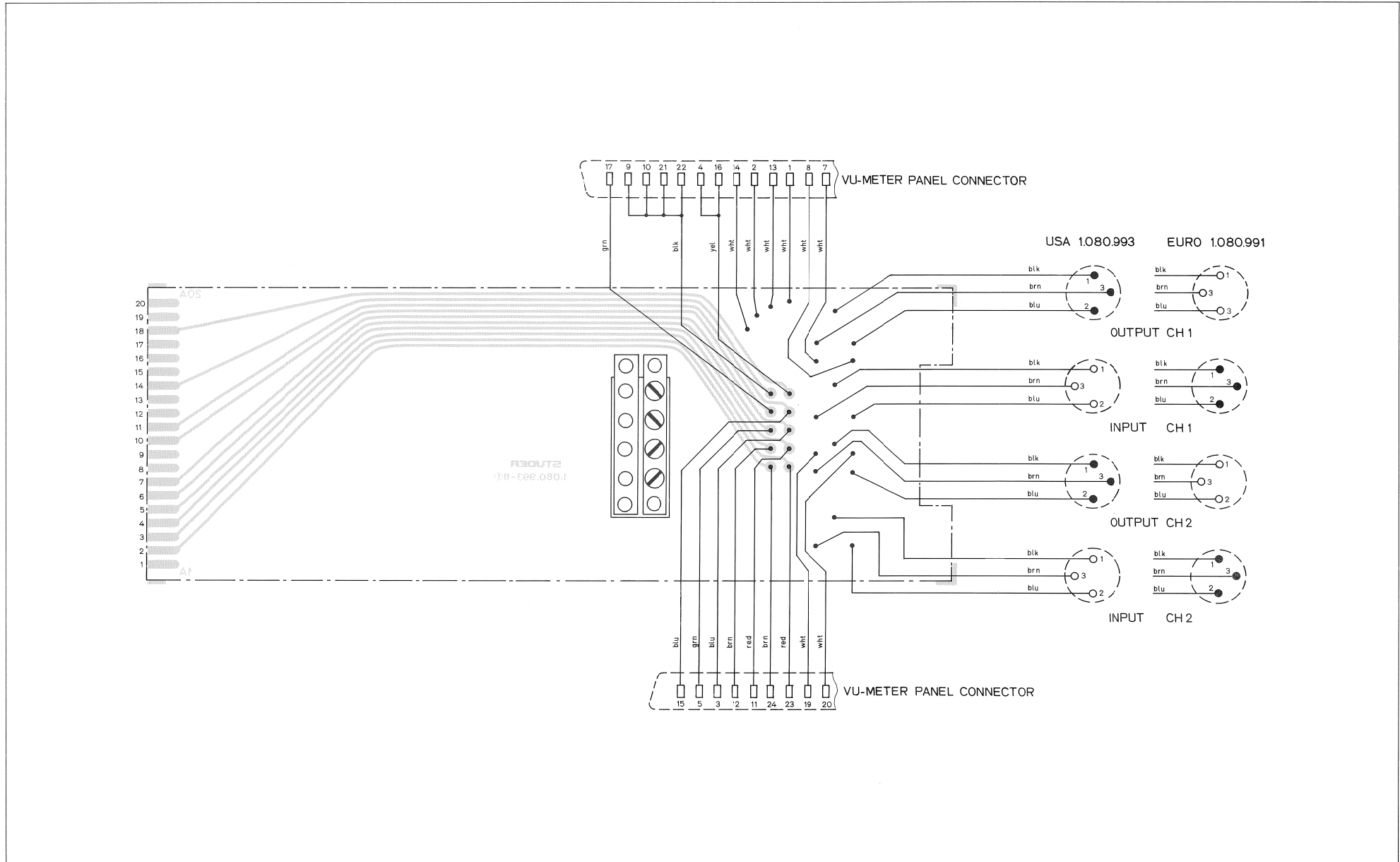

VU-METER PANEL 1.080.950 (WITH VU-METER CONNECTION BOARD 1.081.914)

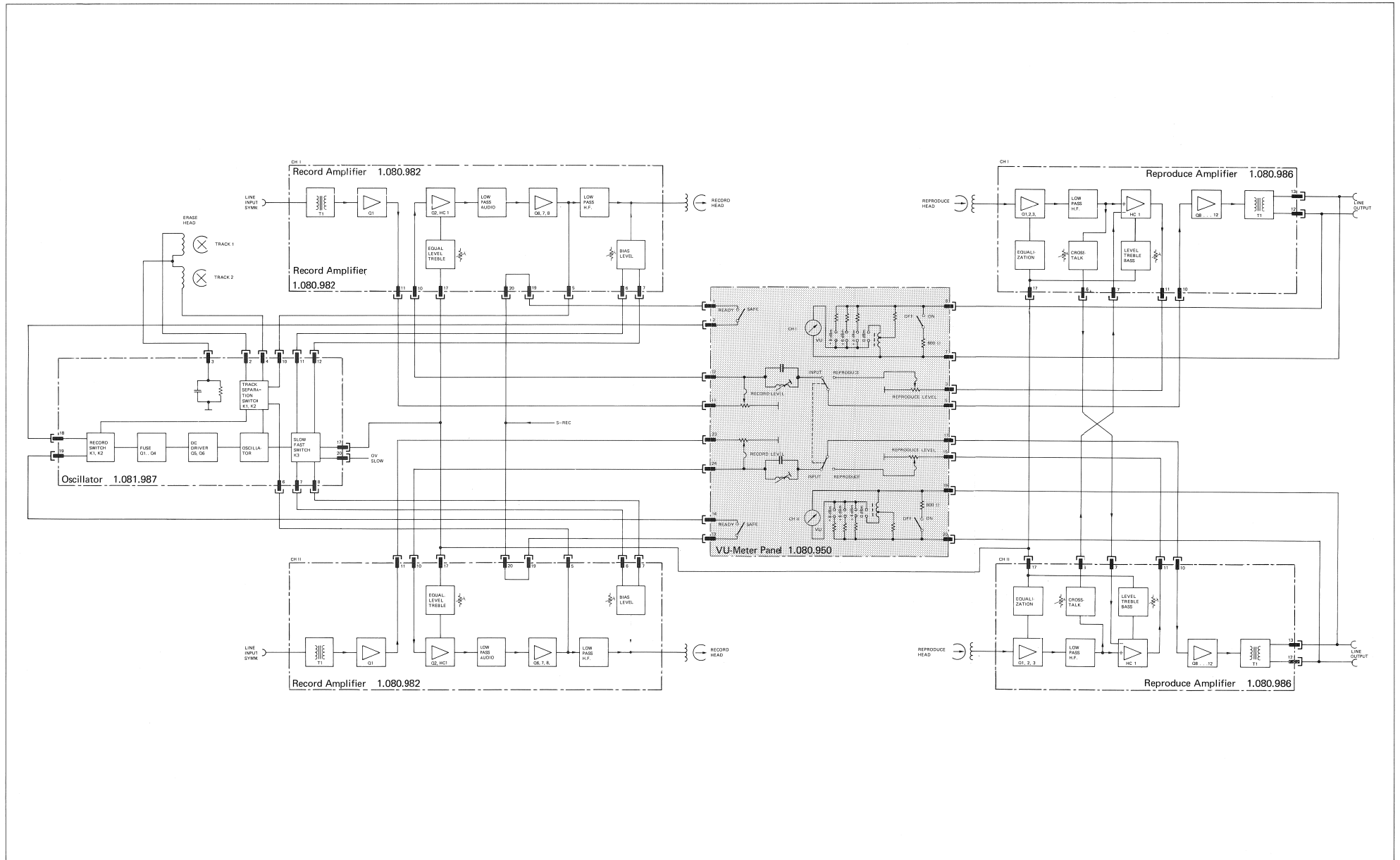

VU-METER PANEL 1.080.950 (WITH VU-METER CONNECTION BOARD 1.081.914)

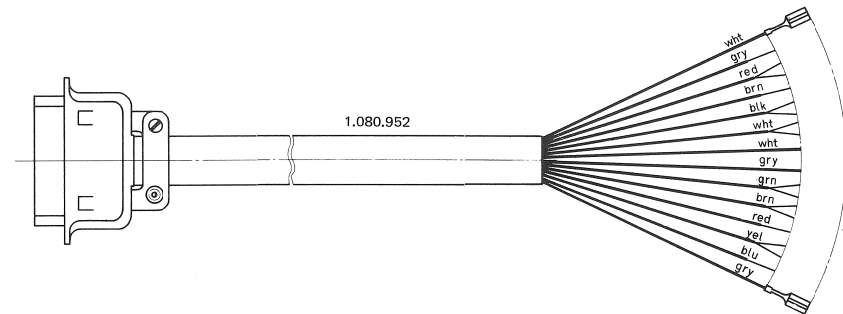
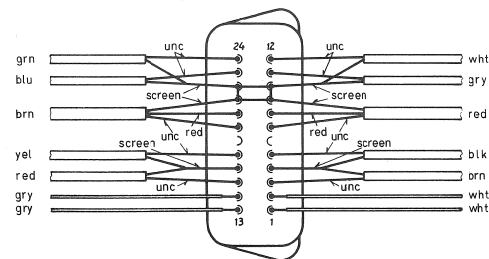
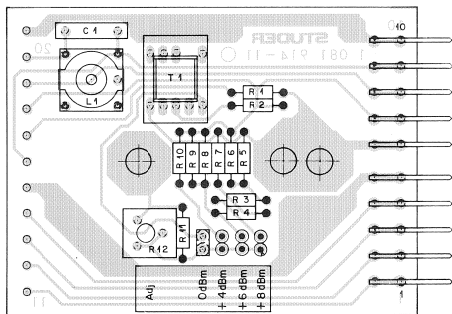
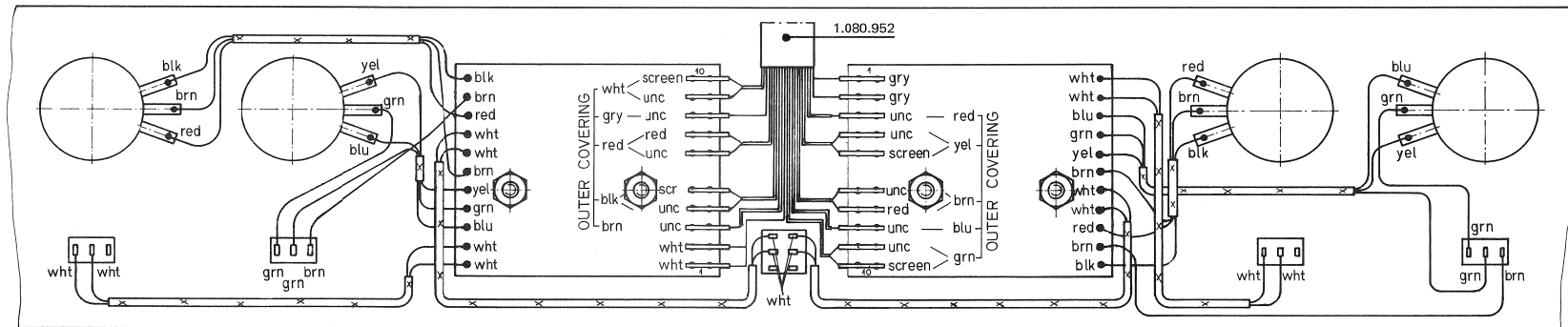
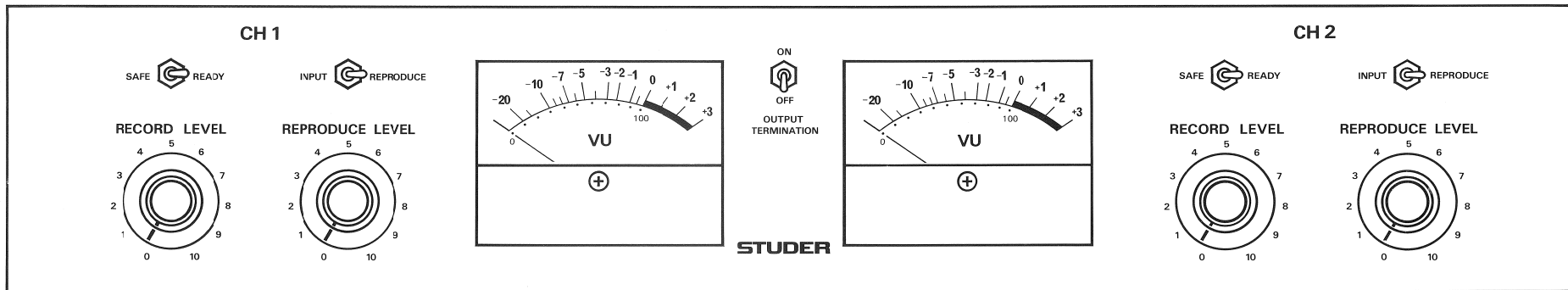

VU-METER PANEL 1.080.950 (WITH VU-METER CONNECTION BOARD 1.081.914)

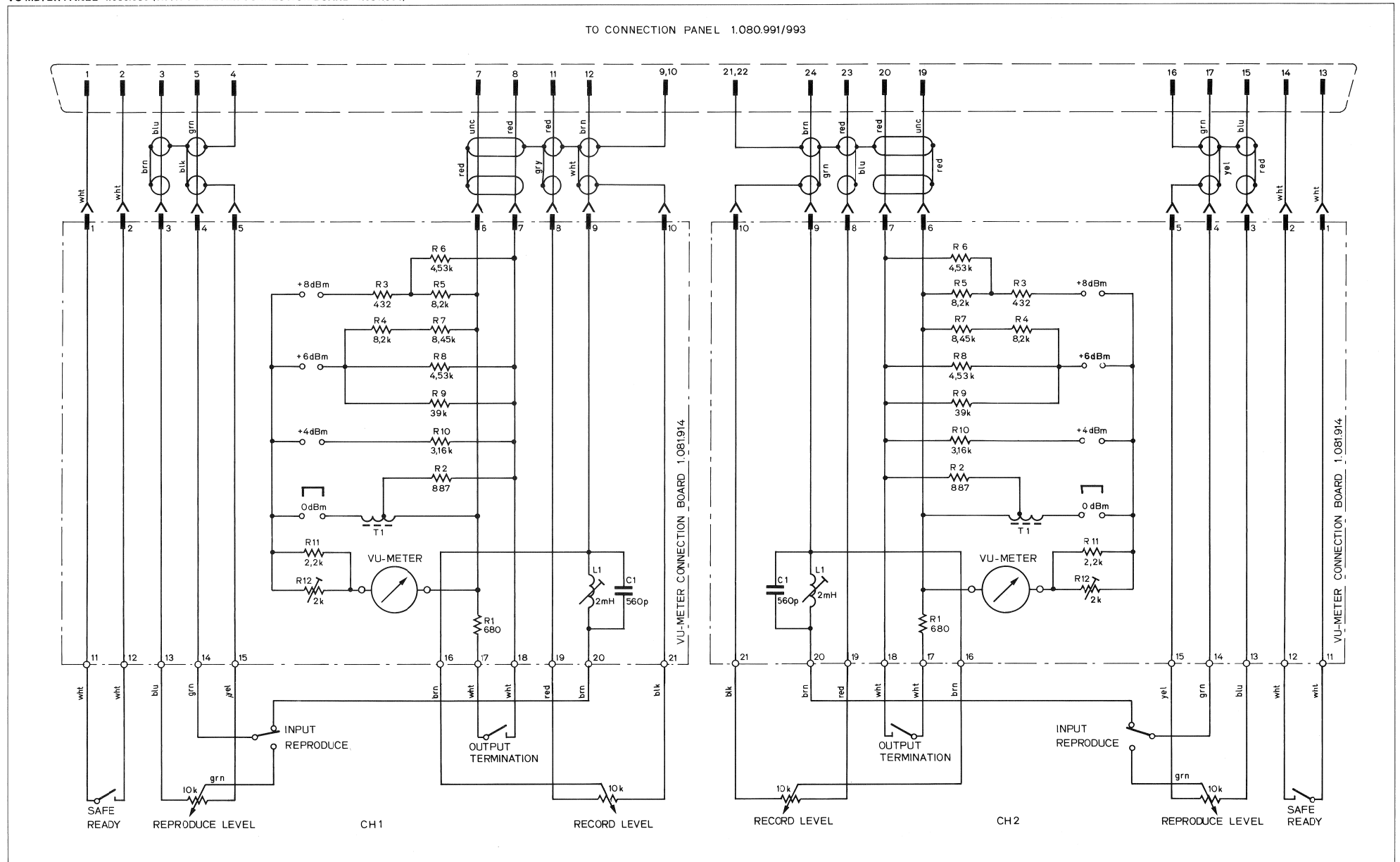

VU-METER PANEL 1.080.950 (WITH VU-METER CONNECTION BOARD 1.081.914)

POS NO	PART NO	VALUE	SPECIFICATIONS	EQUIVALENT MFR
C 1	38 11 4541	500 nF	5%	
L 1	1.022.177.00	2mH		ST
R 1	57 11 4681	480 Ω	5% 0.25W	
R 2	57 39 8870	887 Ω	1%	
R 3	57 39 4520	452 Ω	1%	
R 4	57 11 4622	62 Ω	5%	
R 5	57 11 4622	62 Ω	5%	
R 6	57 39 4521	452 Ω	1%	
R 7	57 39 8451	845 Ω	1%	
R 8	57 39 4521	452 Ω	1%	
R 9	57 11 4292	39 Ω	5%	
R 10	57 39 316 1	316 Ω	1%	
R 11	57 11 4222	22 Ω	5%	
R 12	56 01 2202	20k	10% 0.5W	
T 1	1.022.411.00			ST

ST - STUDER		COPIES NO. 11	DATE 11.01.87	P. NUMBER NAME 23000000
STUDER				
VU-Meter-Connection-Board		1.081.914	DATE	PAGE 1 OF 1

CONTENTS

DESCRIPTION	SCHEMATIC NO.		SECTION/PAGE
EARLIER SCHEMATICS			9
REMOTE MODE CONTROL		GR 22 EL 22	9/3
TAPE MOVE AND DIRECTION SENSOR	1.080.180	GR 14 EL 1/2	9/5
TAPE TIMER ASSEMBLY	1.080.215	GR 18 EL 1	9/7
STABILIZER (TAPE TRANSPORT)	1.080.370	GR 20 EL 2	9/9
CAPSTAN SERVO	1.080.376	GR 20 EL 6	9/11
CONTACTOR	1.080.380	GR 20 EL 4	9/13
IC DECODER AND DRIVERS	1.080.390	GR 20 EL 8	9/15
ATTENUATOR AND PREAMPLIFIER	1.080.396	GR 20 EL 10	9/17
VU-METER PANEL	1.080.950		9/19
RECORD AMPLIFIER	1.080.982		9/21
OSCILLATOR STEREO	1.080.984		9/23
REPRODUCE AMPLIFIER	1.080.986-1		9/25
OSCILLATOR 2 TRACK	1.080.987		9/27
STABILIZER 2 CHANNEL (AUDIO)	1.080.988		9/29
MONO/STEREO SWITCH	1.080.994		9/31
PILOT TONE AMPLIFIER	1.080.996		9/35

REMOTE MODE CONTROL

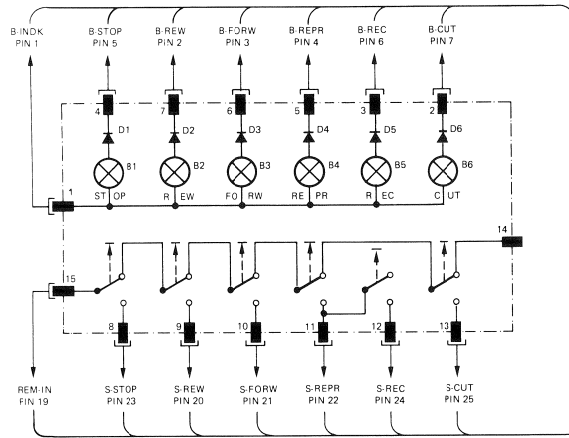

REMOTE CONTROL
FERNSTEUERUNG, LAUFWERK

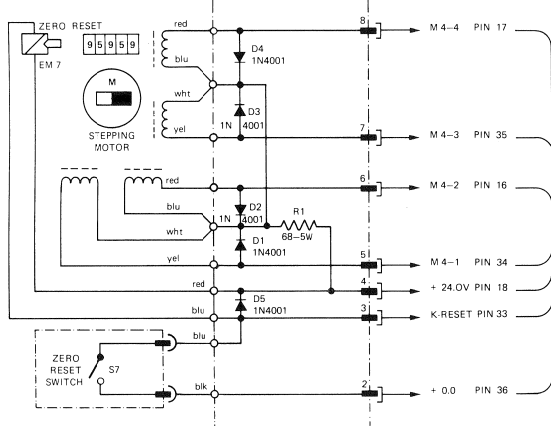

TAPE TIMER ASSEMBLY (REMOTE)
FERN-ZÄHLER

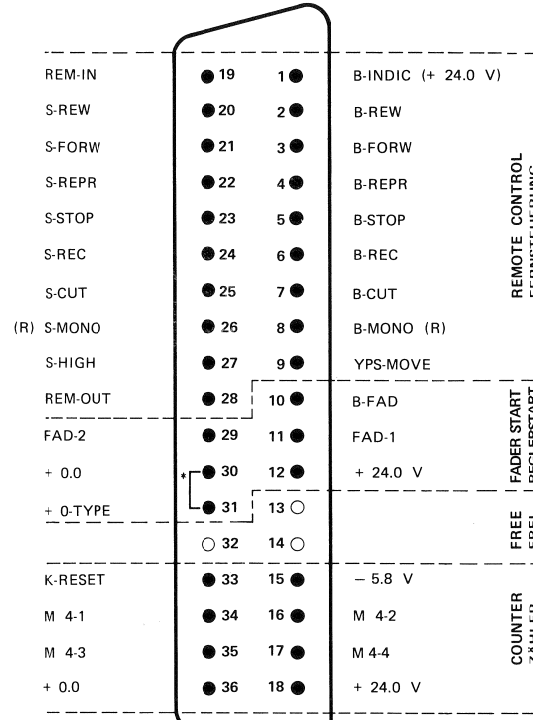

REMOTE MODE CONTROL CONNECTOR
FERNSTEUER-ANSCHLUSS GR 22

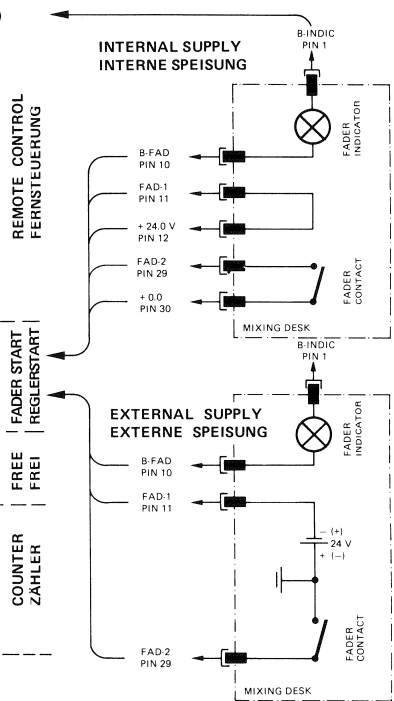

FADER START CIRCUITS
REGLERSTART-SCHALTKREISE

* INTERCONNECTION
IN 15/30 ips MACHINES
VERBINDUNG IN
15/30* -GERÄTEN

TAPE MOVE AND DIRECTION SENSOR 1.080.180

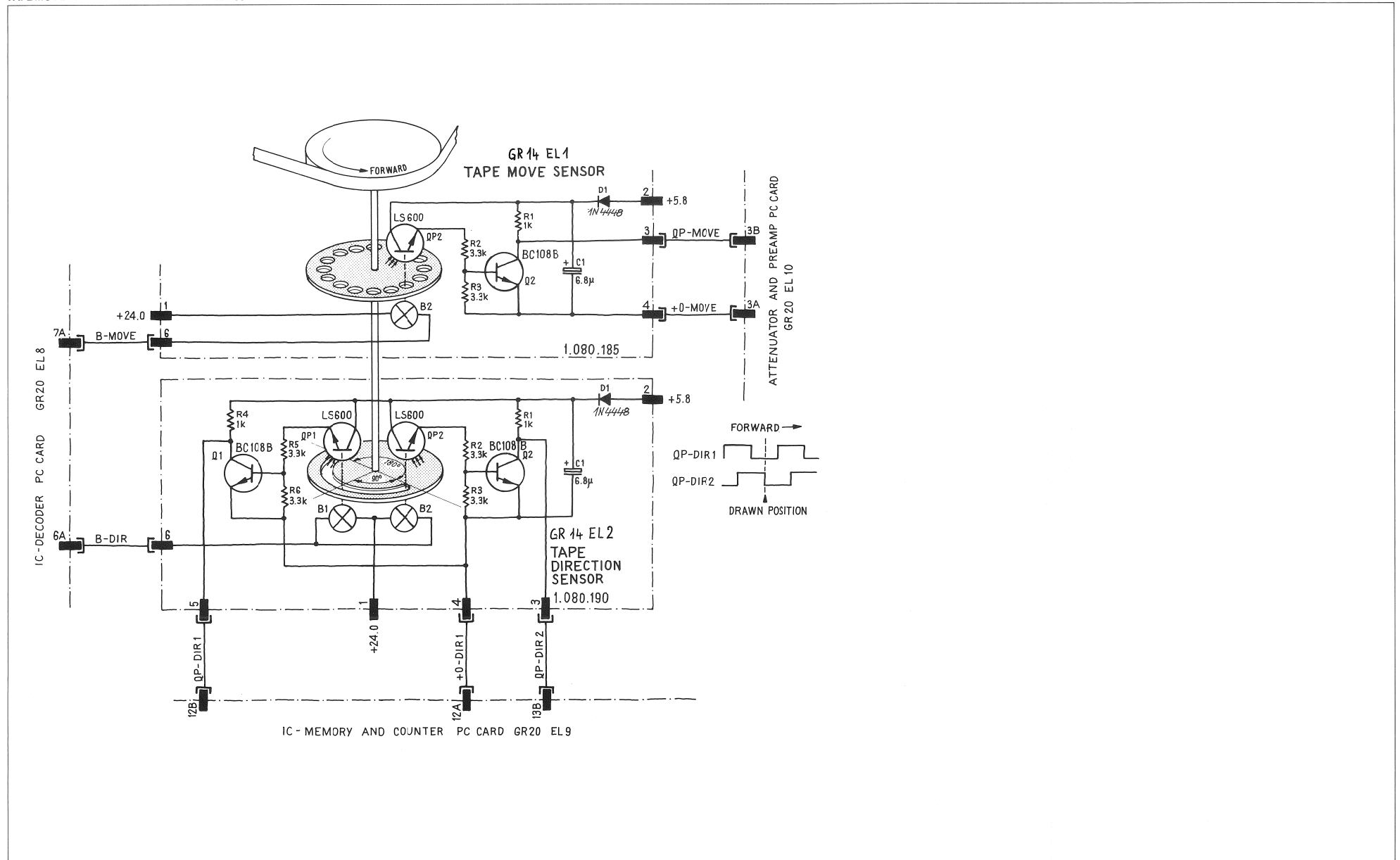

TAPE MOVE AND DIRECTION SENSOR 1.080.180

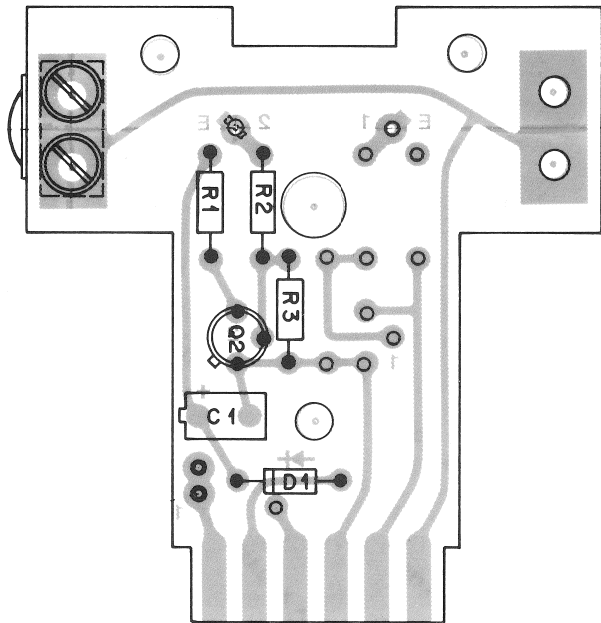
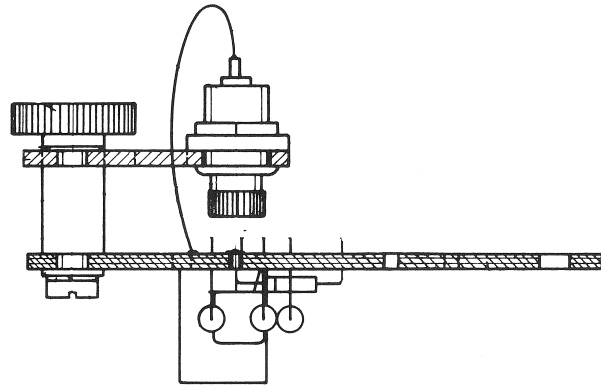

1 2 3 4 5 6

TAPE MOVE SENSOR

1.080.185

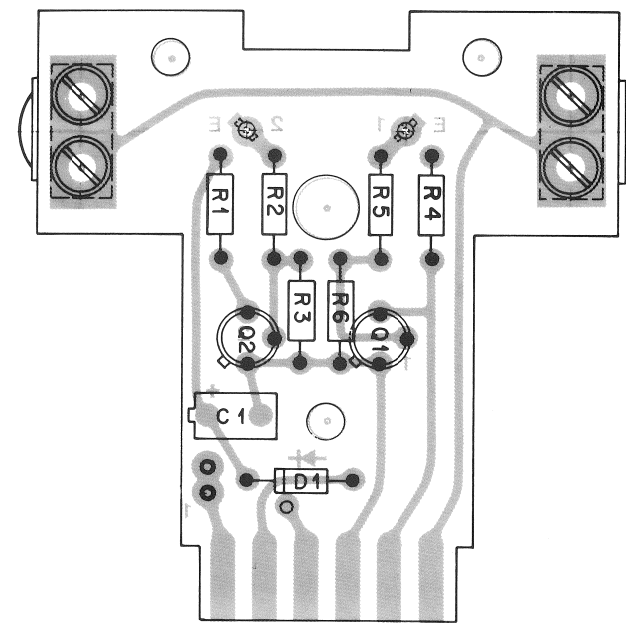
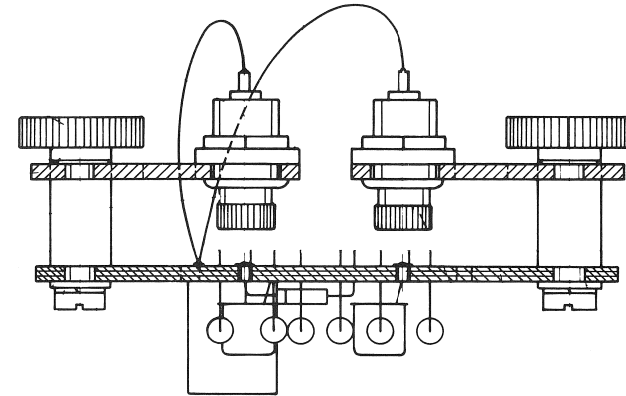

1 2 3 4 5 6

TAPE DIRECTION SENSOR

1.080.190

TAPE TIMER ASSEMBLY 1.080.215

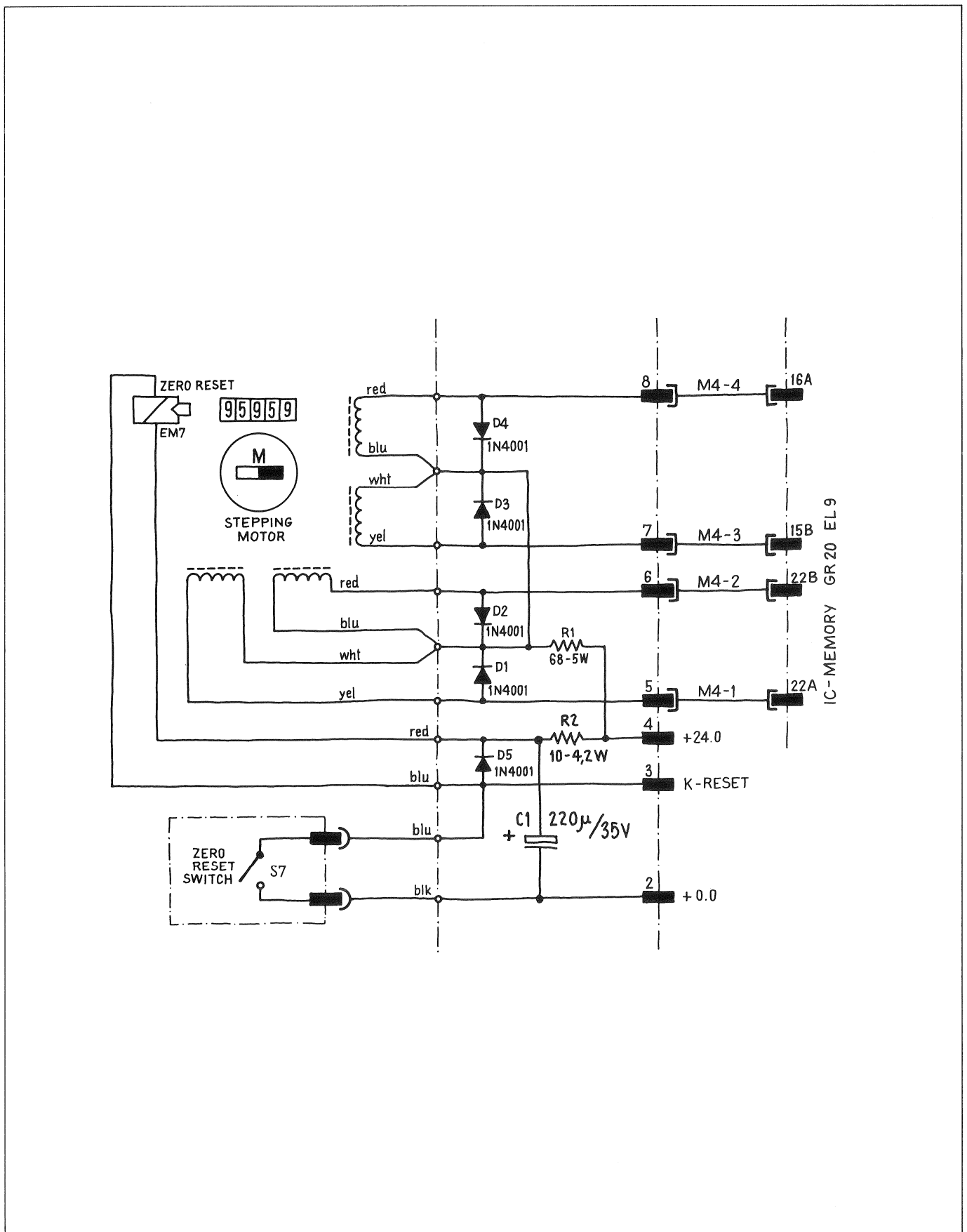

TAPE TIMER ASSEMBLY 1.080.215

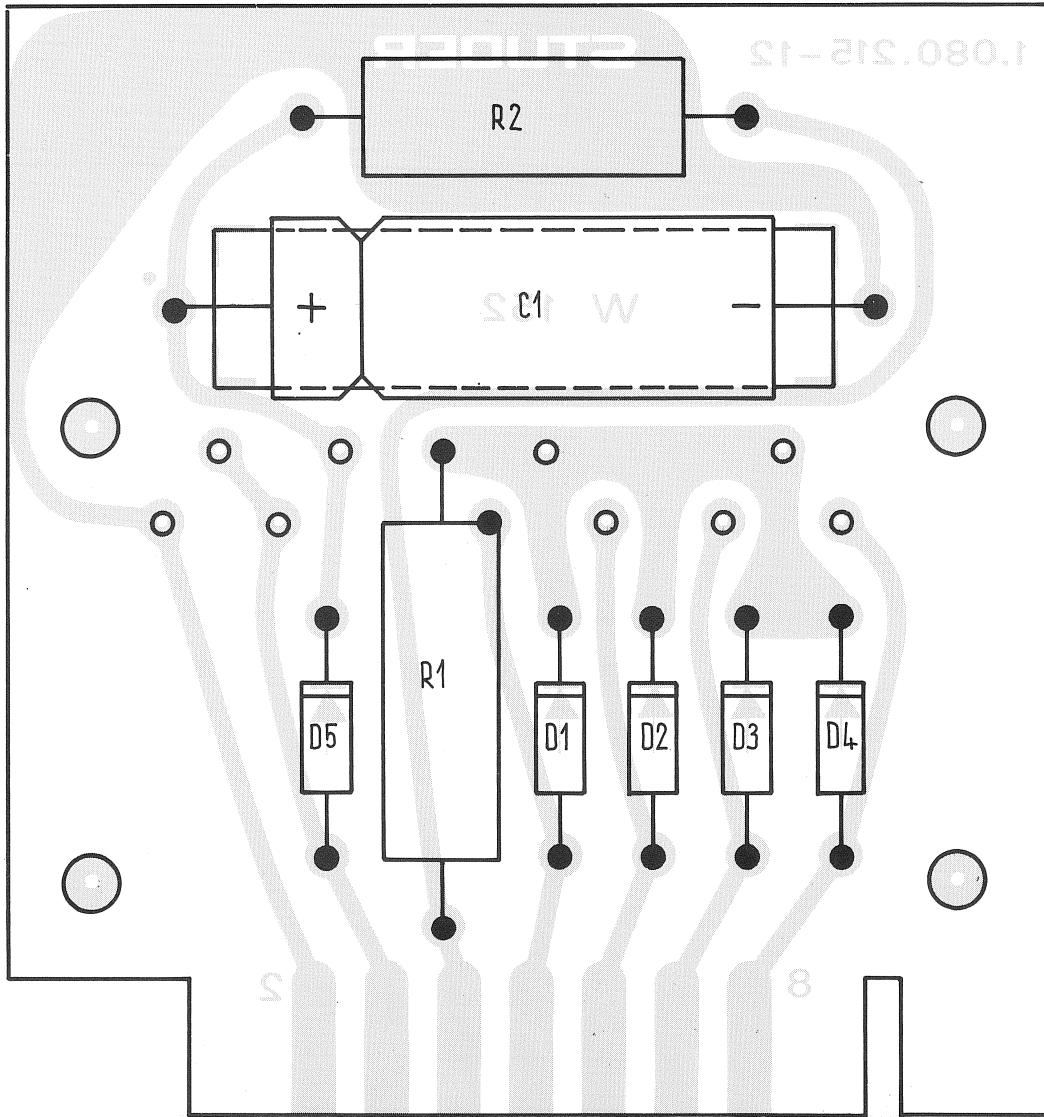

IDENTIFICATION	PART NAME	TYPE / REMARKS	Unspecified carbon film resistors: 1/8 W - 5%	Commercial types
			SPECIFICATIONS	ORDER NUMBER
	Tape Timer Assembly	Board assembled		1.080.215
C 1	Capacitor	elektrolytic	220 μ F - 100% - 35 V	* *
R 1	Resistor	wire - wound	68 - 5% - 5.5 W	* *
R 2	Resistor	wire - wound	10 - 5% - 4.2 W	* *
D 1	Si - Diode	1 N 4001		* *
D 2	Si - Diode	1 N 4001		* *
D 3	Si - Diode	1 N 4001		* *
D 4	Si - Diode	1 N 4001		* *
D 5	Si - Diode	1 N 4001		* *

STABILIZER 1.080.370

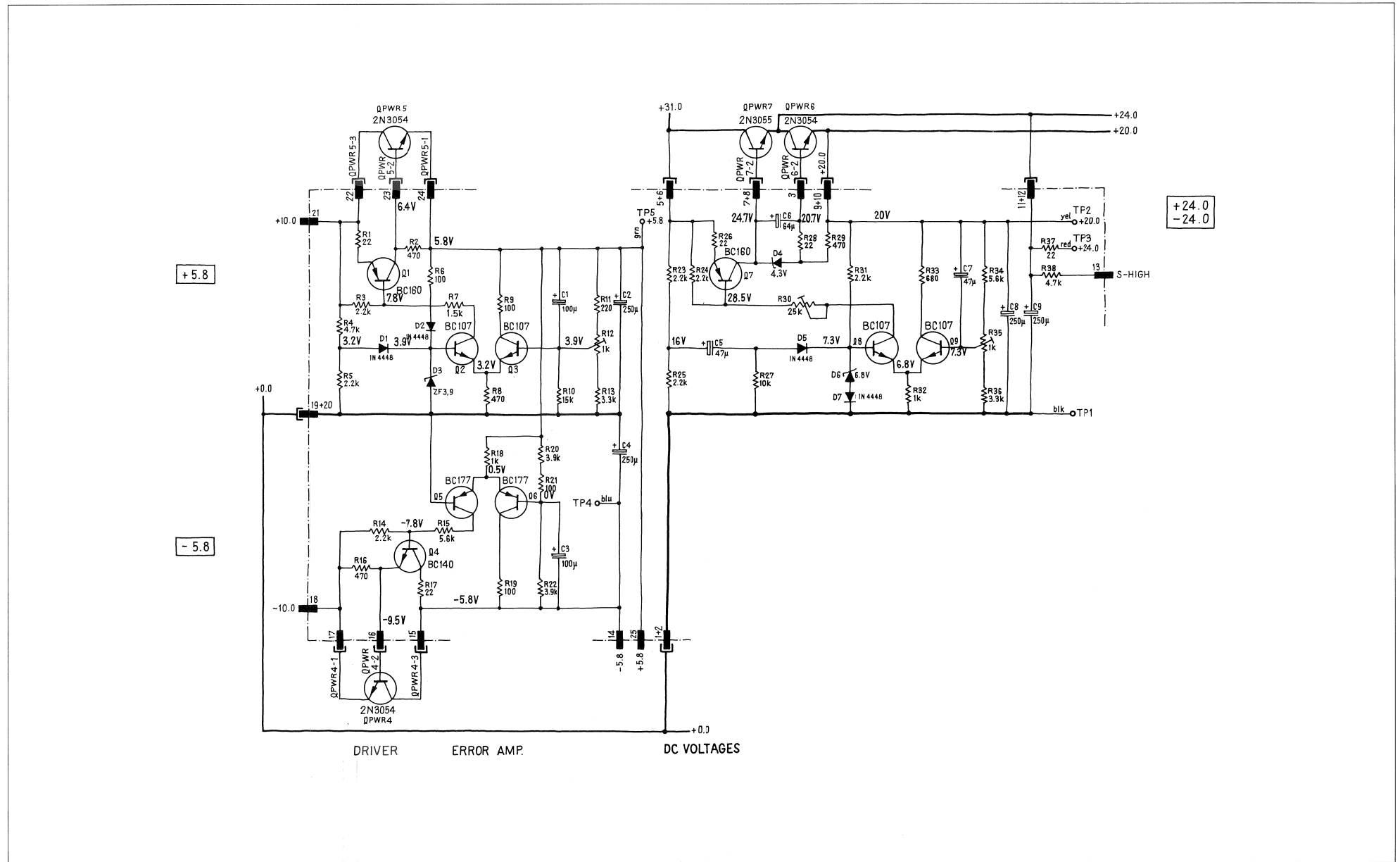

STABILIZER 1.080.370

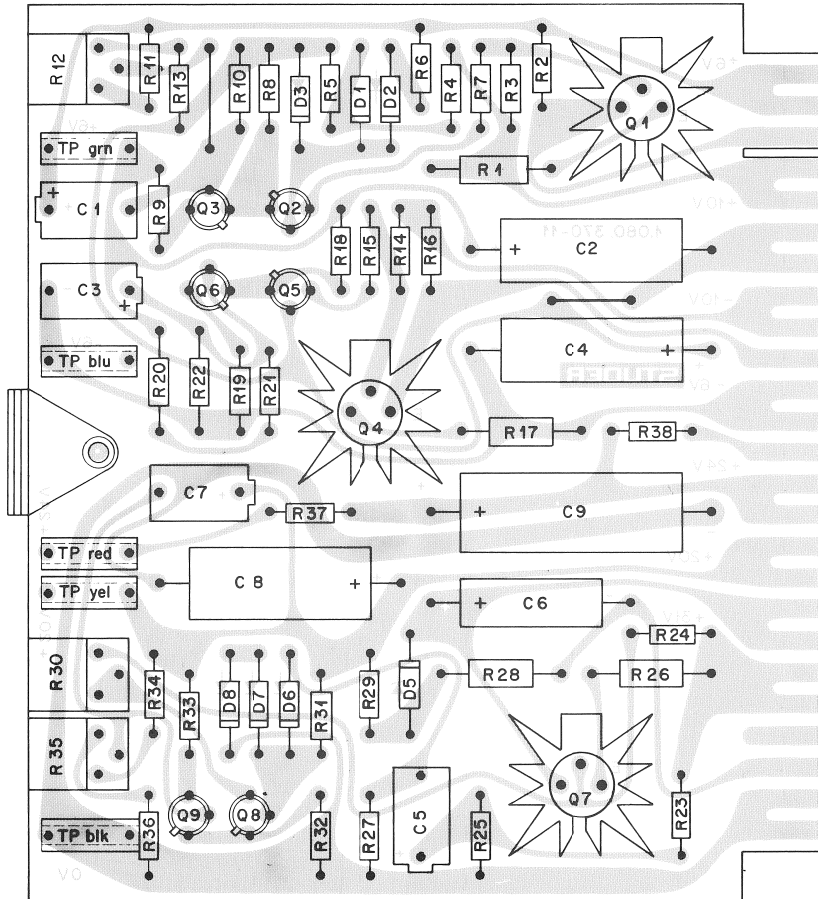

	FIRST	LAST	MISSING
Q	1	9	
R	1	38	
D	1	8	4
C	1	9	

IDENTIFICATION	PART NAME	TYPE / REMARKS	Unspecified carbon film resistors: 10 W - 5%	
			SPECIFICATIONS	ORDER NUMBER
	Stabilizer	Board assembled		1.080.370
C 1	Capacitor	tantalum	100 μ F - 20% - 10 V	..
C 2	Capacitor	elektrolytic	200 μ F - +100% - 16 V	..
C 3	Capacitor	tantalum	100 μ F - 20% - 10 V	..
C 4	Capacitor	elektrolytic	200 μ F - +100% - 16 V	..
C 5	Capacitor	tantalum	17 μ F - 20% - 20 V	..
C 6	Capacitor	elektrolytic	94 μ F - +50% - 10 V	..
C 7	Capacitor	tantalum	47 μ F - 20% - 20 V	..
C 8	Capacitor	elektrolytic	200 μ F - +100% - 25 V	..
C 9	Capacitor	elektrolytic	200 μ F - +100% - 35 V	..
D 1	Si - Diode	1 N 4448		..
D 2	Si - Diode	1 N 4448		..
D 3	Zener - Diode		3.9 V - 5% - 0.4 W	..
D 4	Zener - Diode		4.3 V - 5% - 0.4 W	..
D 5	Si - Diode	1 N 4448		..
D 6	Zener - Diode		6.8 V - 5% - 0.4 W	..
D 7	Si - Diode	1 N 4448		..
Q 1	Transistor	BC 160 - 16		..
Q 2	Transistor	BC 107		..
Q 3	Transistor	BC 107		..
Q 4	Transistor	BC 140 - 16		..
Q 5	Transistor	BC 177		..
Q 6	Transistor	BC 177		..
Q 7	Transistor	BC 160 - 16		..
Q 8	Transistor	BC 107		..
Q 9	Transistor	BC 107		..
R 1	Resistor	carbon film	22 - 5% - 0.33 W	..
R 2	Resistor	carbon film	470	..
R 3	Resistor	carbon film	22 k	..
R 4	Resistor	carbon film	4.7 k	..
R 5	Resistor	carbon film	22 k	..
R 6	Resistor	carbon film	100	..
R 7	Resistor	carbon film	1.5 k	..
R 8	Resistor	carbon film	470	..
R 9	Resistor	carbon film	180	..
R 10	Resistor	carbon film	5 k	..
R 11	Resistor	carbon film	810	..
R 12	Potentiometer	carbon film	1 k - 20% - 0.5 W	..
R 13	Resistor	carbon film	33 k	..
R 14	Resistor	carbon film	22 k	..
R 15	Resistor	carbon film	5.6 k	..
R 16	Resistor	carbon film	470	..

IDENTIFICATION	PART NAME	TYPE / REMARKS	Unspecified carbon film resistors: 10 W - 5%	
			SPECIFICATIONS	ORDER NUMBER
R 17	Resistor	carbon film	22 - 5% - 0.33 W	..
R 18	Resistor	carbon film	1 k	..
R 19	Resistor	carbon film	100	..
R 20	Resistor	metallic oxide	39 k - 1% - 0.25 W	..
R 21	Resistor	carbon film	100	..
R 22	Resistor	metallic oxide	39 k - 1% - 0.25 W	..
R 23	Resistor	carbon film	22 k	..
R 24	Resistor	carbon film	22 k	..
R 25	Resistor	carbon film	22 k	..
R 26	Resistor	carbon film	22 - 5% - 0.33 W	..
R 27	Resistor	carbon film	10 k	..
R 28	Resistor	carbon film	22 - 5% - 0.33 W	..
R 29	Resistor	carbon film	470	..
R 30	Potentiometer	carbon film	25 k - 10% - 0.5 W	..
R 31	Resistor	carbon film	22 k	..
R 32	Resistor	carbon film	1 k	..
R 33	Resistor	carbon film	680	..
R 34	Resistor	carbon film	5.6 k	..
R 35	Potentiometer	carbon film	1 k - 10% - 0.5 W	..
R 36	Resistor	carbon film	33 k	..
R 37	Resistor	carbon film	22	..
R 38	Resistor	carbon film	47 k	..
TP 1	Jack	2 mm - grn		54.01.0015
TP 2	Jack	2 mm - blu		54.01.0016
TP 3	Jack	2 mm - red		54.01.0012
TP 4	Jack	2 mm - yel		54.01.0014
TP 5	Jack	2 mm - blk		54.01.0010

CAPSTAN SERVO 1.080.376

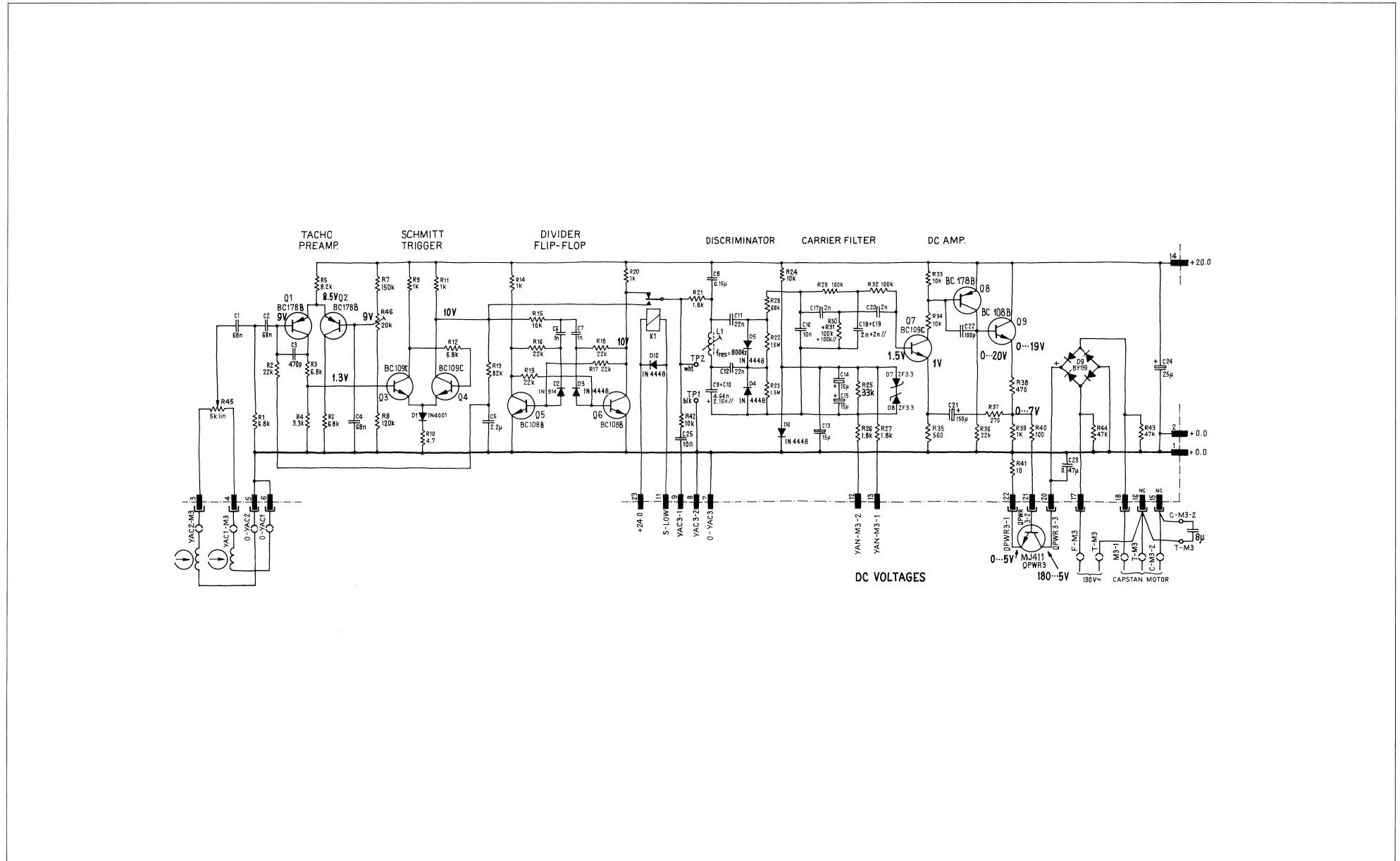

CAPSTAN SERVO 1.080.376

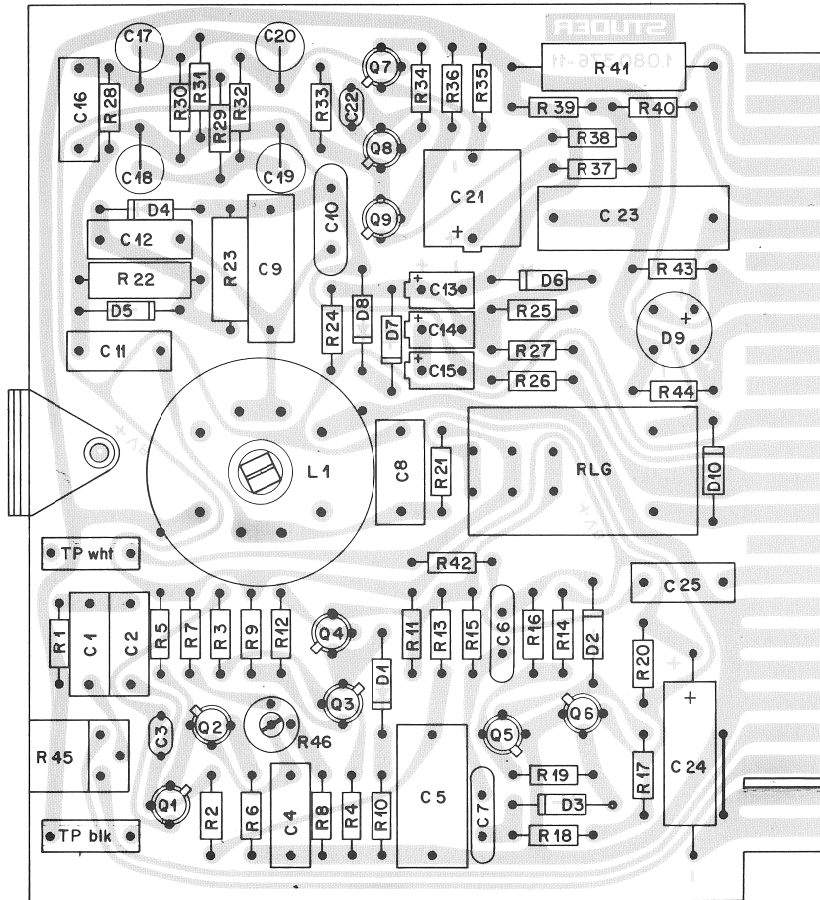

	FIRST	LAST	MISSING
C	1	25	
R	1	46	
Q	1	9	
D	1	10	

25
24
23
22
21
20
19
18
17
16
15
14
13
12
11
10
9
8
7
6
5
4
3
2
1

IDENTIFICATION	PART NAME	TYPE / REMARKS	SPECIFICATIONS	ORDER NUMBER
	Capstan Servo	Board assembled		1.080.376
C 1	Capacitor	polycarbonat	68 n F - 10% - 160 V	**
C 2	Capacitor	polycarbonat	68 n F - 10% - 160 V	**
C 3	Capacitor	ceramic	470 p F - 10% - 500 V	**
C 4	Capacitor	polycarbonat	88 n F - 10% - 160 V	**
C 5	Capacitor	polycarbonat	2,2 µ F - 10% - 63 V	**
C 6	Capacitor	ceramic	1 n F - 20% - 500 V	**
C 7	Capacitor	ceramic	1 n F - 20% - 500 V	**
C 8	Capacitor	polycarbonat	150 n F - 10% - 160 V	**
C 9	Capacitor	polystyrol	464 n F - 1% - 200 V	**
C 10	Capacitor	mica	215 n F - 1% - 300 V	**
C 11	Capacitor	polycarbonat	22 n F - 10% - 250 V	**
C 12	Capacitor	polycarbonat	22 n F - 10% - 250 V	**
C 13	Capacitor	tantalum	15 µ F - 20% - 20 V	**
C 14	Capacitor	tantalum	15 µ F - 20% - 20 V	**
C 15	Capacitor	tantalum	15 µ F - 20% - 20 V	**
C 16	Capacitor	polycarbonat	15 n F - 10% - 250 V	**
C 17	Capacitor	polystyrol	2 n F - 1% - 125 V	**
C 18	Capacitor	polystyrol	2 n F - 1% - 125 V	**
C 19	Capacitor	polystyrol	2 n F - 1% - 125 V	**
C 20	Capacitor	polystyrol	2 n F - 1% - 125 V	**
C 21	Capacitor	tantalum	150 µ F - 20% - 16 V	**
C 22	Capacitor	ceramic	100 µ F - 10% - 500 V	**
C 23	Capacitor	metalized paper	0,47 µ F - 10% - 150 V	**
C 24	Capacitor	elektrolytic	25 µ F - 50% - 25 V	**
C 25	Capacitor	polycarbonat	10 n F - 10% - 250 V	**
D 1	Diode	Si - Diode	1 N 4448	**
D 2	Diode	Si - Diode	1 N 4448	**
D 3	Diode	Si - Diode	1 N 4448	**
D 4	Diode	Si - Diode	1 N 4448	**
D 5	Diode	Si - Diode	1 N 4448	**
D 6	Diode	Si - Diode	1 N 4448	**
D 7	Zener - Diode		3,3 V - 5% - 0,4 W	**
D 8	Zener - Diode		3,3 V - 5% - 0,4 W	**
D 9	Rectifier		B Y 150/400	**
D 10	Diode	Si - Diode	1 N 914	**
K 1	Relay (DC)		24 V - - 0,4 A	56.04.0126
L 1	Discriminator Coil			1.080.378.00
Q 1	Transistor	BC 178 B		**
Q 2	Transistor	BC 178 B		**
Q 3	Transistor	BC 109 C		**

IDENTIFICATION	PART NAME	TYPE / REMARKS	SPECIFICATIONS	ORDER NUMBER
R 43	Resistor	carbon film	47 k	**
R 44	Resistor	carbon film	47 k	**
R 45	Potentiometer	carbon film	5 k - 10% - 0,5 W	**
R 46	Potentiometer	carbon film	20 k - 30% - 0,5 W	**
TP 1	Jack		2 mm - blk	54.01.0010
TP 2	Jack		2 mm - wht	54.01.0019

IDENTIFICATION	PART NAME	TYPE / REMARKS	SPECIFICATIONS	ORDER NUMBER
Q 4	Transistor	BC 109 C		**
Q 5	Transistor	BC 108 B		**
Q 6	Transistor	BC 108 B		**
Q 7	Transistor	BC 109 C		**
Q 8	Transistor	BC 178 B		**
Q 9	Transistor	BC 108 B		**
R 1	Resistor	carbon film	6,3 k	**
R 2	Resistor	carbon film	22 k	**
R 3	Resistor	carbon film	6,3 k	**
R 4	Resistor	carbon film	3,3 k	**
R 5	Resistor	carbon film	8,2 k	**
R 6	Resistor	carbon film	6,3 k	**
R 7	Resistor	carbon film	150 k	**
R 8	Resistor	carbon film	120 k	**
R 9	Resistor	carbon film	1 k	**
R 10	Resistor	carbon film	4,7	**
R 11	Resistor	carbon film	1 k	**
R 12	Resistor	carbon film	6,8 k	**
R 13	Resistor	carbon film	82 k	**
R 14	Resistor	carbon film	1 k	**
R 15	Resistor	carbon film	10 k	**
R 16	Resistor	carbon film	22 k	**
R 17	Resistor	carbon film	22 k	**
R 18	Resistor	carbon film	22 k	**
R 19	Resistor	carbon film	22 k	**
R 20	Resistor	carbon film	1 k	**
R 21	Resistor	carbon film	1,8 k	**
R 22	Resistor	carbon composition	1,8 M - 5% - 0,25 W	**
R 23	Resistor	carbon composition	1,8 M - 5% - 0,25 W	**
R 24	Resistor	carbon film	10 k	**
R 25	Resistor	carbon film	33 k	**
R 26	Resistor	carbon film	1,8 k	**
R 27	Resistor	carbon film	1,8 k	**
R 28	Resistor	carbon film	68 k	**
R 29	Resistor	metallic oxide	100 k - 1% - 0,25 W	**
R 30	Resistor	metallic oxide	100 k - 1% - 0,25 W	**
R 31	Resistor	metallic oxide	100 k - 1% - 0,25 W	**
R 32	Resistor	metallic oxide	100 k - 1% - 0,25 W	**
R 33	Resistor	carbon film	10 k	**
R 34	Resistor	carbon film	10 k	**
R 35	Resistor	carbon film	560	**
R 36	Resistor	carbon film	22 k	**
R 37	Resistor	carbon film	270	**
R 38	Resistor	carbon film	470	**
R 39	Resistor	carbon film	100	**
R 40	Resistor	carbon film	100	**
R 41	Resistor	wire - wound	10 - 10% - 5,5 W	**
R 42	Resistor	carbon film	10 k	**

CONTACTOR 1.080.380

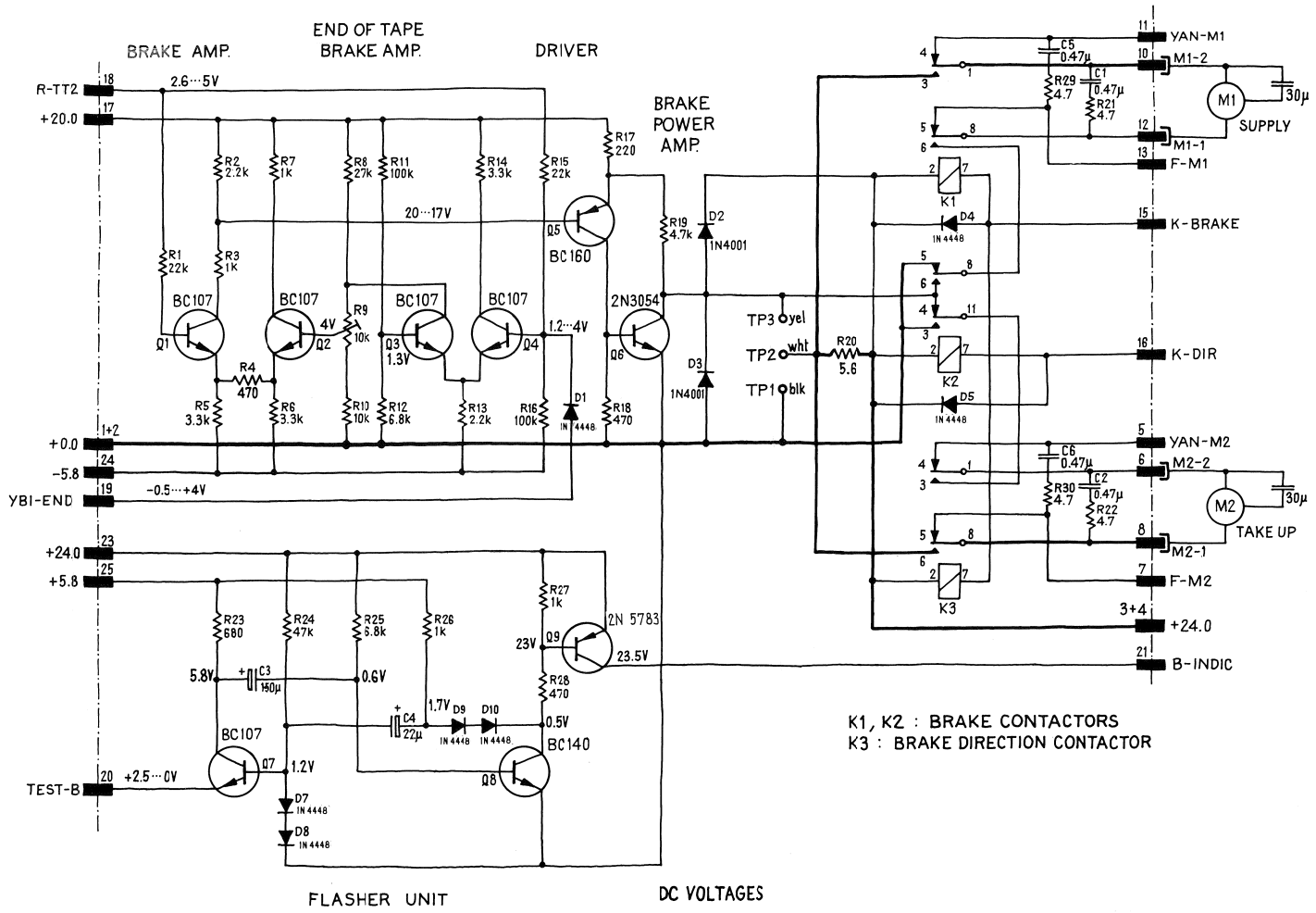

CONTACTOR 1.080.380

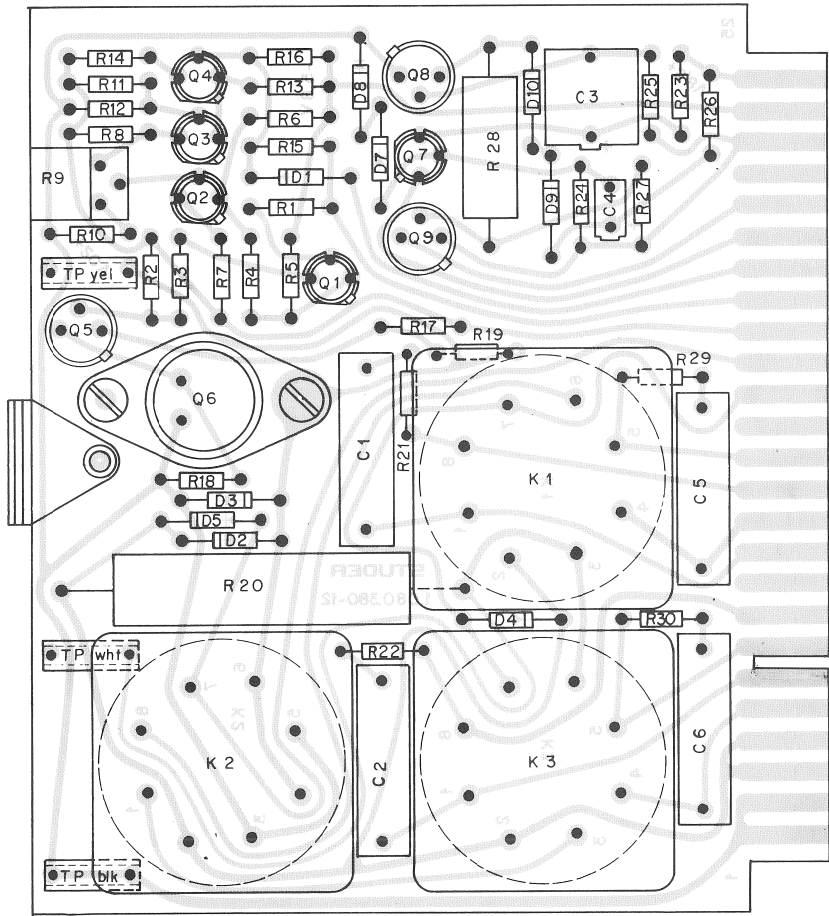

25
24
23
22
21
20
19
18
17
16
15
14
13
12
11
10
9
8
7
6
5
4
3
2
1

IDENTIFICATION	PART NAME	TYPE / REMARKS	SPECIFICATIONS	ORDER NUMBER
	Contactor	Board assembled		1.080.380
C1	Capacitor	metallized paper	0,47 µF - 10% - 150 V	** *
C2	Capacitor	metallized paper	0,47 µF - 10% - 150 V	** *
C3	Capacitor	tantalum	150 µF - 20% - 16 V	** *
C4	Capacitor	tantalum	22 µF - 20% - 6,3 V	** *
C5	Capacitor	metallized paper	0,47 µF - 10% - 150 V	** *
C6	Capacitor	metallized paper	0,47 µF - 10% - 150 V	** *
D 1	Si - Diode	1 N 4448		** *
D 2	Si - Diode	1 N 4001		** *
D 3	Si - Diode	1 N 4001		** *
D 4	Si - Diode	1 N 4448		** *
D 5	Si - Diode	1 N 4448		** *
D 7	Si - Diode	1 N 4448		** *
D 8	Si - Diode	1 N 4448		** *
D 9	Si - Diode	1 N 4448		** *
D 10	Si - Diode	1 N 4448		** *
K 1	Contactor	24 V -		56.02.0106
K 2	Contactor	24 V -		56.02.0106
K 3	Contactor	24 V -		56.02.0106
Q 1	Transistor	BC 107 A		** *
Q 2	Transistor	BC 107 A		** *
Q 3	Transistor	BC 107 A		** *
Q 4	Transistor	BC 107 A		** *
Q 5	Transistor	BC 105 - 18		** *
Q 6	Transistor	2 N 3054		** *
Q 7	Transistor	BC 107 A		** *
Q 8	Transistor	BC 145 - 18		** *
Q 9	Transistor	2 N 5783		** *
R 1	Resistor	carbon film	22 k	** *
R 2	Resistor	carbon film	2,2 k	** *
R 3	Resistor	carbon film	1 k	** *
R 4	Resistor	carbon film	47	** *
R 5	Resistor	carbon film	3,3 k	** *
R 6	Resistor	carbon film	3,3 k	** *
R 7	Resistor	carbon film	1 k	** *
R 8	Resistor	carbon film	27 k	** *
R 9	Potentiometer	carbon film	10 k - 10% - 0,5 W	** *
R 10	Resistor	carbon film	10 k	** *
R 11	Resistor	carbon film	100 k	** *
R 12	Resistor	carbon film	68 k	** *
R 13	Resistor	carbon film	2,2 k	** *

IDENTIFICATION	PART NAME	TYPE / REMARKS	SPECIFICATIONS	ORDER NUMBER
R 14	Resistor	carbon film	3,3 k	** *
R 15	Resistor	carbon film	22 k	** *
R 16	Resistor	carbon film	100 k	** *
R 17	Resistor	carbon film	220	** *
R 18	Resistor	carbon film	470	** *
R 19	Resistor	carbon film	4,7 k	** *
R 20	Resistor	wire - wound	58 - 10% - 10 W	** *
R 21	Resistor	carbon composition	4,7 - 10% - 0,25 W	** *
R 22	Resistor	carbon composition	4,7 - 10% - 0,25 W	** *
R 23	Resistor	carbon film	680	** *
R 24	Resistor	carbon film	47 k	** *
R 25	Resistor	carbon film	68 k	** *
R 26	Resistor	carbon film	1 k	** *
R 27	Resistor	carbon film	1 k	** *
R 28	Resistor	wire - wound	410 - 5% - 4,2 W	** *
R 29	Resistor	carbon composition	4,7 - 10% - 0,25 W	** *
R 30	Resistor	carbon composition	4,7 - 10% - 0,25 W	** *
TP 1	Jack		2mm - blk	54.01.0010
TP 2	Jack		2mm - wht	54.01.0013
TP 3	Jack		2mm - yel	54.01.0014

	FIRST	LAST	MISSING
R	1	30	
C	1	6	
D	1	10	6
Q	1	9	

IC DECODER AND DRIVERS 1.080.390

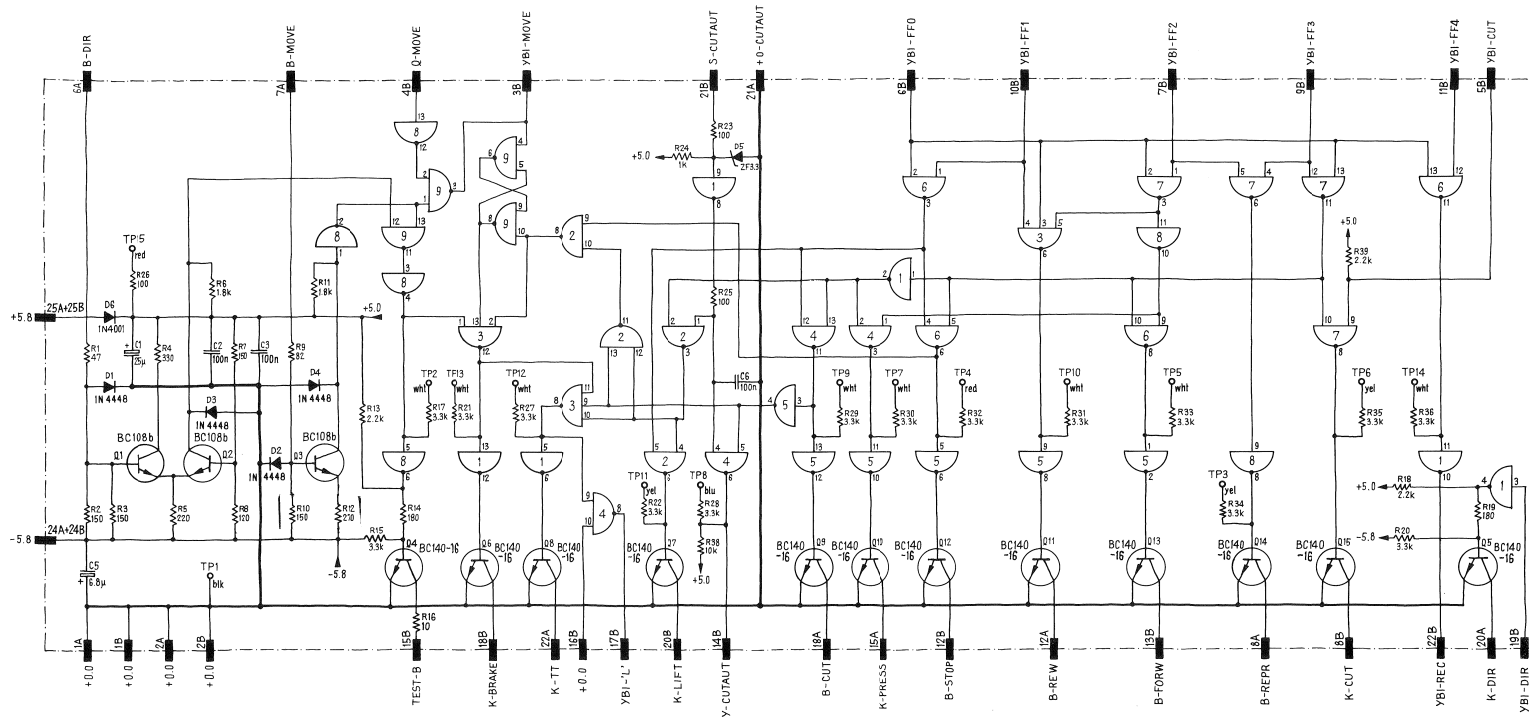

IC DECODER AND DRIVERS 1.080.390

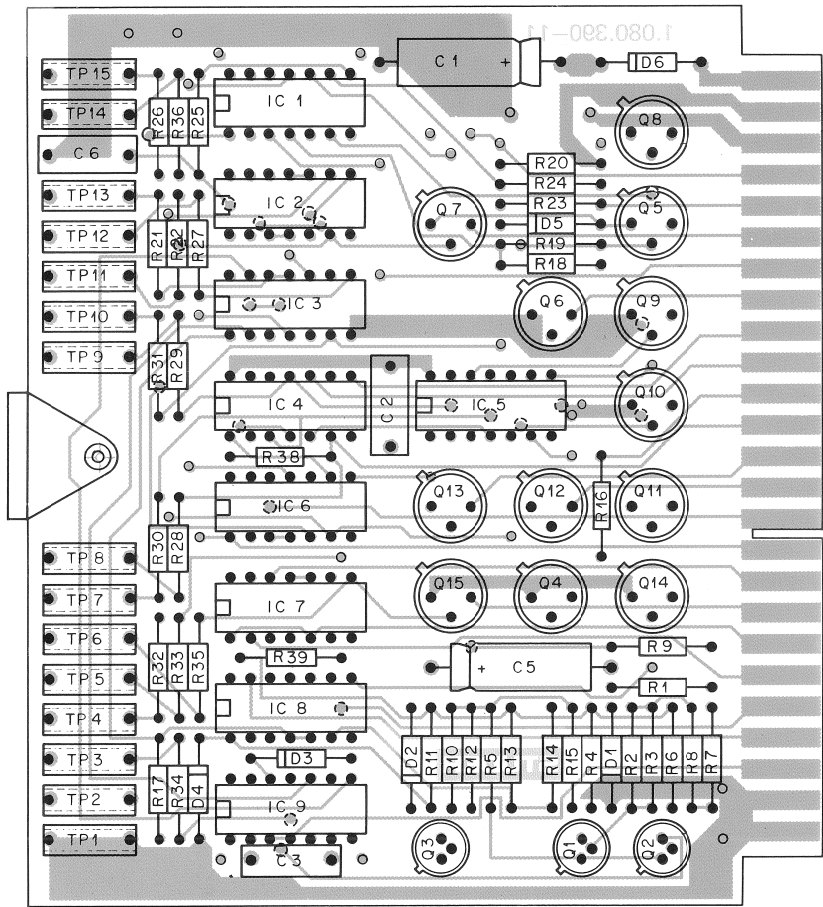

	FIRST	LAST	MISSING
IC	1	9	
Q	1	15	
R	1	39	37
D	1	6	
C	1	6	4

IDENTIFICATION	PART NAME	TYPE / REMARKS	SPECIFICATIONS	ORDER NUMBER
	IC Decoder and Driver	Board assembled		1.080.390
C 1	Capacitor	electrolytic	25 µ F - 160% - 25 V	.. *
C 2	Capacitor	polycarbonat	100 n F - 10% - 160 V	.. *
C 3	Capacitor	polycarbonat	100 n F - 10% - 160 V	.. *
C 5	Capacitor	electrolytic	25 µ F - 160% - 25 V	.. *
C 6	Capacitor	polycarbonat	100 n F - 10% - 160 V	.. *
D 1	Si - Diode	1 N 4448		.. *
D 2	Si - Diode	1 N 4448		.. *
D 3	Si - Diode	1 N 4448		.. *
D 4	Si - Diode	1 N 4448		.. *
D 5	Zener - Diode		3,3 V - 5% - 0,4 W	.. *
D 6	Si - Diode	1 N 4001		.. *
IC 1	Integrated Circuit	SN 7404 N		.. *
IC 2	Integrated Circuit	SN 7400 N		.. *
IC 3	Integrated Circuit	SN 7410 N		.. *
IC 4	Integrated Circuit	SN 7400 N		.. *
IC 5	Integrated Circuit	SN 7404 N		.. *
IC 6	Integrated Circuit	SN 7400 N		.. *
IC 7	Integrated Circuit	SN 7400 N		.. *
IC 8	Integrated Circuit	SN 7404 N		.. *
IC 9	Integrated Circuit	SN 7400 N		.. *
Q 1	Transistor	BC 108 B		.. *
Q 2	Transistor	BC 108 B		.. *
Q 3	Transistor	BC 108 B		.. *
Q 4	Transistor	BC 140 - 16		.. *
Q 5	Transistor	BC 140 - 16		.. *
Q 6	Transistor	BC 140 - 16		.. *
Q 7	Transistor	BC 140 - 16		.. *
Q 8	Transistor	BC 140 - 16		.. *
Q 9	Transistor	BC 140 - 16		.. *
Q 10	Transistor	BC 140 - 16		.. *
Q 11	Transistor	BC 140 - 16		.. *
Q 12	Transistor	BC 140 - 16		.. *
Q 13	Transistor	BC 140 - 16		.. *
Q 14	Transistor	BC 140 - 16		.. *
Q 15	Transistor	BC 140 - 16		.. *
R 1	Resistor	metal film	47 - 2% - 0,25 W	.. *
R 2	Resistor	metal film	150 - 2% - 0,25 W	.. *
R 3	Resistor	metal film	150 - 2% - 0,25 W	.. *
R 4	Resistor	carbon composition	330 - 10% - 0,25 W	.. *
R 5	Resistor	carbon composition	220 - 10% - 0,25 W	.. *

IDENTIFICATION	PART NAME	TYPE / REMARKS	SPECIFICATIONS	ORDER NUMBER
R 6	Resistor	carbon composition	1,8 k - 10% - 0,25 W	.. *
R 7	Resistor	metal film	150 - 2% - 0,25 W	.. *
R 8	Resistor	metal film	120 - 2% - 0,25 W	.. *
R 9	Resistor	carbon composition	82 - 10% - 0,25 W	.. *
R 10	Resistor	carbon composition	150 - 10% - 0,25 W	.. *
R 11	Resistor	carbon composition	1,8 k - 10% - 0,25 W	.. *
R 12	Resistor	carbon composition	270 - 10% - 0,25 W	.. *
R 13	Resistor	carbon composition	2,2 k - 10% - 0,25 W	.. *
R 14	Resistor	carbon composition	180 - 10% - 0,25 W	.. *
R 15	Resistor	carbon composition	3,3 k - 10% - 0,25 W	.. *
R 16	Resistor	carbon composition	10 - 10% - 0,25 W	.. *
R 17	Resistor	carbon composition	3,3 k - 10% - 0,25 W	.. *
R 18	Resistor	carbon composition	2,2 k - 10% - 0,25 W	.. *
R 19	Resistor	carbon composition	180 - 10% - 0,25 W	.. *
R 20	Resistor	carbon composition	3,3 k - 10% - 0,25 W	.. *
R 21	Resistor	carbon composition	3,3 k - 10% - 0,25 W	.. *
R 22	Resistor	carbon composition	3,3 k - 10% - 0,25 W	.. *
R 23	Resistor	carbon composition	100 - 10% - 0,25 W	.. *
R 24	Resistor	carbon composition	1 k - 10% - 0,25 W	.. *
R 25	Resistor	carbon composition	100 - 10% - 0,25 W	.. *
R 26	Resistor	carbon composition	100 - 10% - 0,25 W	.. *
R 27	Resistor	carbon composition	3,3 k - 10% - 0,25 W	.. *
R 28	Resistor	carbon composition	3,3 k - 10% - 0,25 W	.. *
R 29	Resistor	carbon composition	3,3 k - 10% - 0,25 W	.. *
R 30	Resistor	carbon composition	3,3 k - 10% - 0,25 W	.. *
R 31	Resistor	carbon composition	3,3 k - 10% - 0,25 W	.. *
R 32	Resistor	carbon composition	3,3 k - 10% - 0,25 W	.. *
R 33	Resistor	carbon composition	3,3 k - 10% - 0,25 W	.. *
R 34	Resistor	carbon composition	3,3 k - 10% - 0,25 W	.. *
R 35	Resistor	carbon composition	3,3 k - 10% - 0,25 W	.. *
R 36	Resistor	carbon composition	3,3 k - 10% - 0,25 W	.. *
R 38	Resistor	carbon composition	10 k - 10% - 0,25 W	.. *
R 39	Resistor	carbon composition	2,2 k - 10% - 0,25 W	.. *
TP 1	Jack	2mm - blk		54.01.0010
TP 2	Jack	2mm - wht		54.01.0019
TP 3	Jack	2mm - yel		54.01.0014
TP 4	Jack	2mm - red		54.01.0012
TP 5	Jack	2mm - wht		54.01.0019
TP 6	Jack	2mm - yel		54.01.0014
TP 7	Jack	2mm - wht		54.01.0019
TP 8	Jack	2mm - blu		54.01.0016
TP 9	Jack	2mm - wht		54.01.0019
TP 10	Jack	2mm - wht		54.01.0019
TP 11	Jack	2mm - yel		54.01.0014
TP 12	Jack	2mm - wht		54.01.0019
TP 13	Jack	2mm - wht		54.01.0019
TP 14	Jack	2mm - wht		54.01.0019
TP 15	Jack	2mm - red		54.01.0012

ATTENUATOR AND PREAMPLIFIER 1.080.396

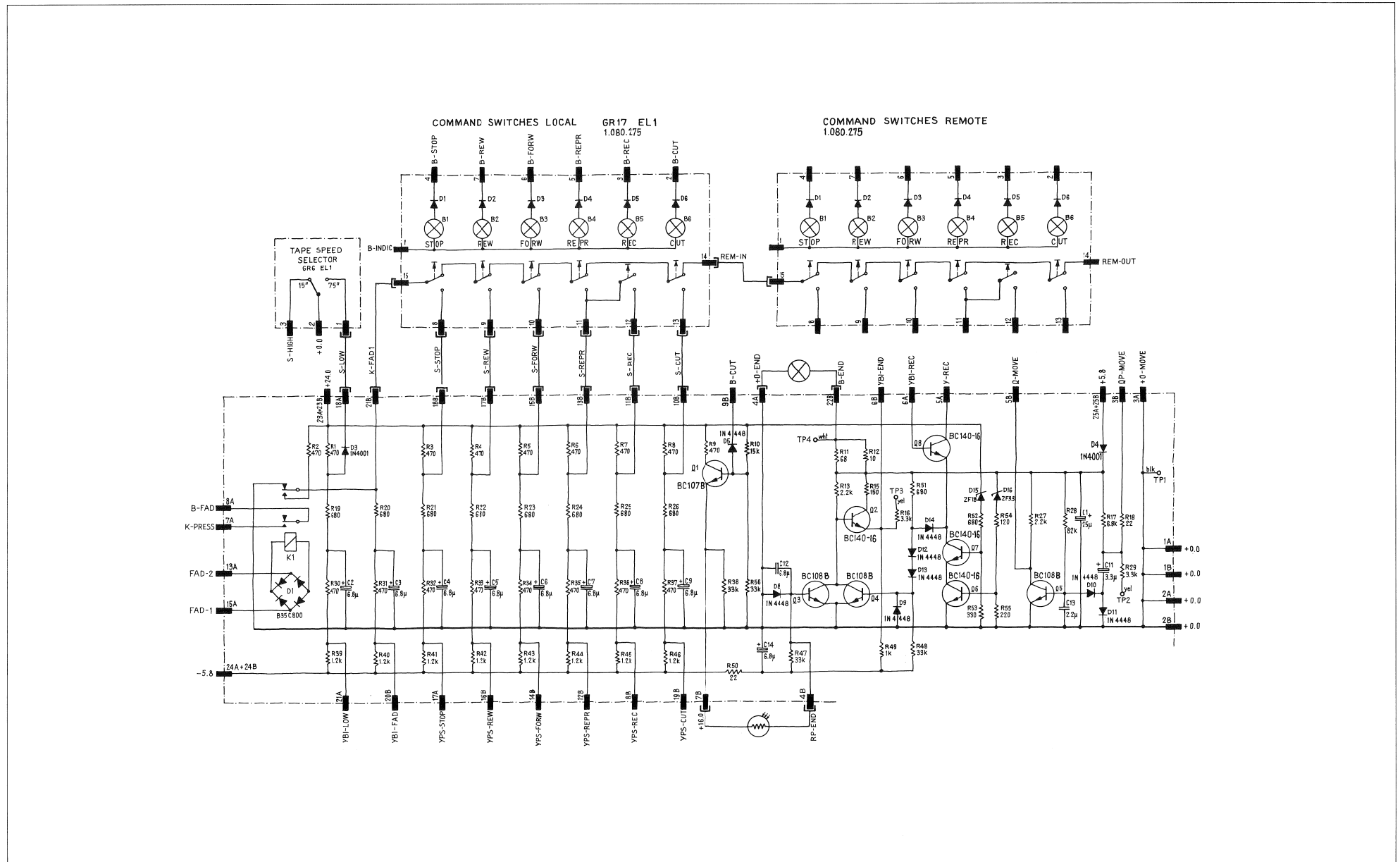

ATTENUATOR AND PREAMPLIFIER 1.080.396

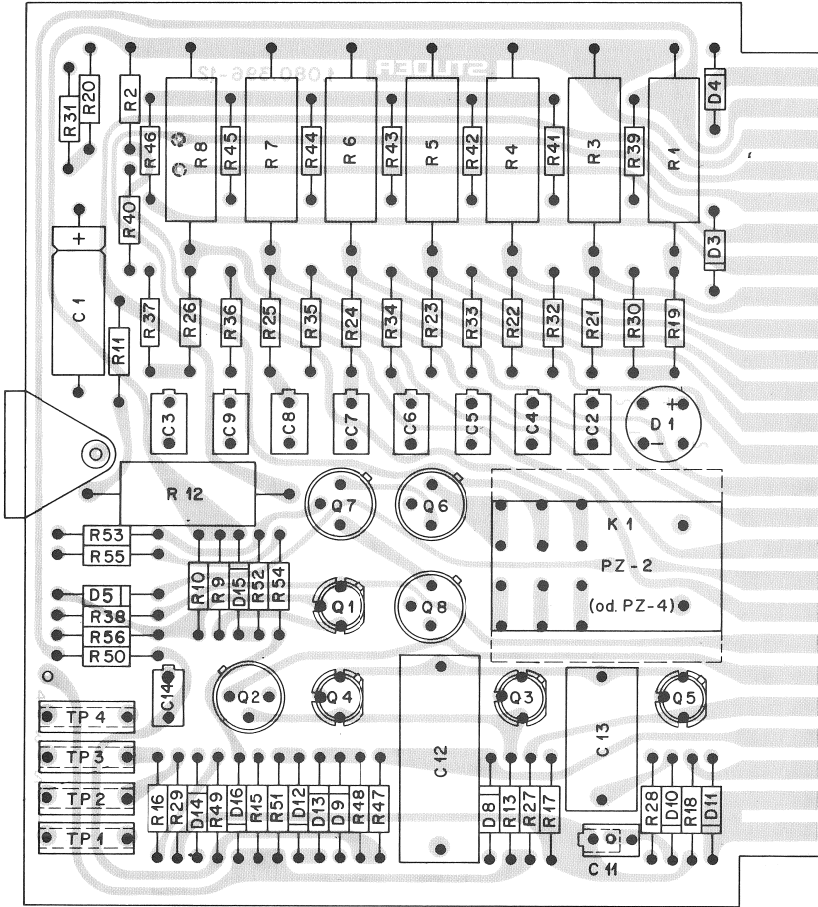

25
24
23
22
21
20
19
18
17
16
15
14
13
12
11
10
9
8
7
6
5
4
3
2
1

	FIRST	LAST	MISSING
Q	1	8	
R	1	56	12,14
D	1	16	2,6,7
C	1	14	10

IDENTIFICATION	PART NAME	TYPE / REMARKS	SPECIFICATIONS	Commercial types	
				ORDER NUMBER	
	Attenuator and Preamplifier	Board assembled		1.080.396	
C 1	Capacitor	electrolytic	25 μ F - +50% - 25 V		
C 2	Capacitor	tantalum	6,8 μ F - 20% - 35 V		
C 3	Capacitor	tantalum	6,8 μ F - 20% - 35 V		
C 4	Capacitor	tantalum	6,8 μ F - 20% - 35 V		
C 5	Capacitor	tantalum	6,8 μ F - 20% - 35 V		
C 6	Capacitor	tantalum	6,8 μ F - 20% - 35 V		
C 7	Capacitor	tantalum	6,8 μ F - 20% - 35 V		
C 8	Capacitor	tantalum	6,8 μ F - 20% - 35 V		
C 9	Capacitor	tantalum	6,8 μ F - 20% - 35 V		
C 10	Capacitor	tantalum	3,3 μ F - 20% - 20 V		
C 12	Capacitor	polycarbonat	6,8 μ F - 10% - 63 V		
C 13	Capacitor	polycarbonat	2,2 μ F - 10% - 63 V		
C 14	Capacitor	tantalum	6,8 μ F - 20% - 20 V		
D 1	Rectifier	B 35 C 800			
D 4	Si - Diode	1 N 4446			
D 5	Si - Diode	1 N 4446			
D 8	Si - Diode	1 N 4446			
D 9	Si - Diode	1 N 4446			
D 10	Si - Diode	1 N 4446			
D 11	Si - Diode	1 N 4446			
D 12	Si - Diode	1 N 4446			
D 13	Si - Diode	1 N 4446			
D 14	Si - Diode	1 N 4446			
D 15	Zener - Diode		18 V - 5% - 0,4 W		
D 16	Zener - Diode		3,3 V - 5% - 0,4 W		
K 1	Relay (DC)		24 V - 0,03 A	56.04.0126	
Q 1	Transistor	BC 107 B			
Q 2	Transistor	BC 140 - 16			
Q 3	Transistor	BC 108 B			
Q 4	Transistor	BC 108 B			
Q 5	Transistor	BC 108 B			
Q 6	Transistor	BC 140 - 16			
Q 7	Transistor	BC 140 - 16			
Q 8	Transistor	BC 140 - 16			
R 1	Resistor	wire - wound	470 - 5% - 5,5 W		
R 2	Resistor	carbon composition	470 - 10% - 0,25 W		
R 3	Resistor	wire - wound	470 - 5% - 5,5 W		
R 4	Resistor	wire - wound	470 - 5% - 5,5 W		
R 5	Resistor	wire - wound	470 - 5% - 5,5 W		
R 6	Resistor	wire - wound	470 - 5% - 5,5 W		

IDENTIFICATION	PART NAME	TYPE / REMARKS	SPECIFICATIONS	Commercial types	
				ORDER NUMBER	
R 7	Resistor	wire - wound	470 - 5% - 5,5 W		
R 8	Resistor	wire - wound	470 - 5% - 5,5 W		
R 9	Resistor	carbon composition	470 - 10% - 0,25 W		
R 10	Resistor	carbon composition	15 k - 10% - 0,25 W		
R 11	Resistor	carbon composition	68 - 10% - 0,25 W		
R 12	Resistor	wire - wound	10 - 10% - 5,5 W		
R 13	Resistor	carbon composition	2,2 k - 10% - 0,25 W		
R 15	Resistor	carbon composition	150 - 10% - 0,25 W		
R 16	Resistor	carbon composition	3,3 k - 10% - 0,25 W		
R 17	Resistor	carbon composition	4,8 k - 10% - 0,25 W		
R 18	Resistor	carbon composition	22 - 10% - 0,25 W		
R 19	Resistor	carbon composition	680 - 10% - 0,25 W		
R 20	Resistor	carbon composition	680 - 10% - 0,25 W		
R 21	Resistor	carbon composition	680 - 10% - 0,25 W		
R 22	Resistor	carbon composition	680 - 10% - 0,25 W		
R 23	Resistor	carbon composition	680 - 10% - 0,25 W		
R 24	Resistor	carbon composition	680 - 10% - 0,25 W		
R 25	Resistor	carbon composition	680 - 10% - 0,25 W		
R 26	Resistor	carbon composition	680 - 10% - 0,25 W		
R 27	Resistor	carbon composition	2,2 k - 10% - 0,25 W		
R 28	Resistor	carbon composition	32 k - 10% - 0,25 W		
R 29	Resistor	carbon composition	3,3 k - 10% - 0,25 W		
R 30	Resistor	carbon composition	470 - 10% - 0,25 W		
R 31	Resistor	carbon composition	470 - 10% - 0,25 W		
R 32	Resistor	carbon composition	470 - 10% - 0,25 W		
R 33	Resistor	carbon composition	470 - 10% - 0,25 W		
R 34	Resistor	carbon composition	470 - 10% - 0,25 W		
R 35	Resistor	carbon composition	470 - 10% - 0,25 W		
R 36	Resistor	carbon composition	470 - 10% - 0,25 W		
R 37	Resistor	carbon composition	470 - 10% - 0,25 W		
R 38	Resistor	carbon composition	33 k - 10% - 0,25 W		
R 39	Resistor	carbon composition	12 k - 10% - 0,25 W		
R 40	Resistor	carbon composition	12 k - 10% - 0,25 W		
R 41	Resistor	carbon composition	12 k - 10% - 0,25 W		
R 42	Resistor	carbon composition	12 k - 10% - 0,25 W		
R 43	Resistor	carbon composition	12 k - 10% - 0,25 W		
R 44	Resistor	carbon composition	12 k - 10% - 0,25 W		
R 45	Resistor	carbon composition	12 k - 10% - 0,25 W		
R 46	Resistor	carbon composition	12 k - 10% - 0,25 W		
R 47	Resistor	carbon composition	33 k - 10% - 0,25 W		
R 48	Resistor	carbon composition	33 k - 10% - 0,25 W		
R 49	Resistor	carbon composition	1 k - 10% - 0,25 W		
R 50	Resistor	carbon composition	22 - 10% - 0,25 W		
R 51	Resistor	carbon composition	680 - 10% - 0,25 W		
R 52	Resistor	carbon composition	680 - 10% - 0,25 W		
R 53	Resistor	carbon composition	330 - 10% - 0,25 W		
R 54	Resistor	carbon composition	100 - 10% - 0,25 W		
R 55	Resistor	carbon composition	220 - 10% - 0,25 W		
R 56	Resistor	carbon composition	33 k - 10% - 0,25 W		

IDENTIFICATION	PART NAME	TYPE / REMARKS	SPECIFICATIONS	Commercial types	
				ORDER NUMBER	
TP 1	Jack		2 mm - blk	54.01.0010	
TP 2	Jack		2 mm - yel	54.01.0014	
TP 3	Jack		2 mm - yel	54.01.0014	
TP 4	Jack		2 mm - wht	54.01.0016	

VU-METER PANEL 1.080.950

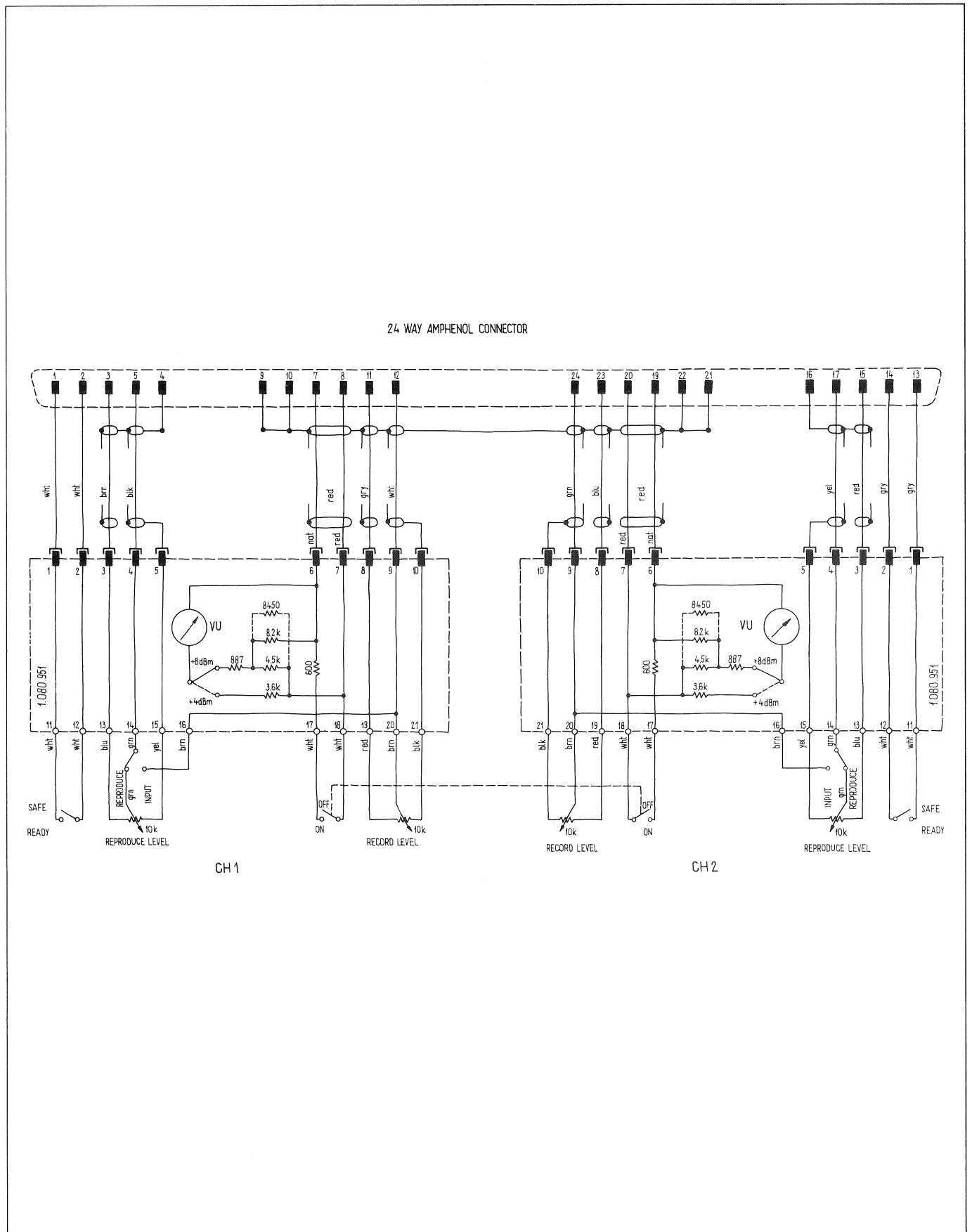

RECORD AMPLIFIER 1.080.982

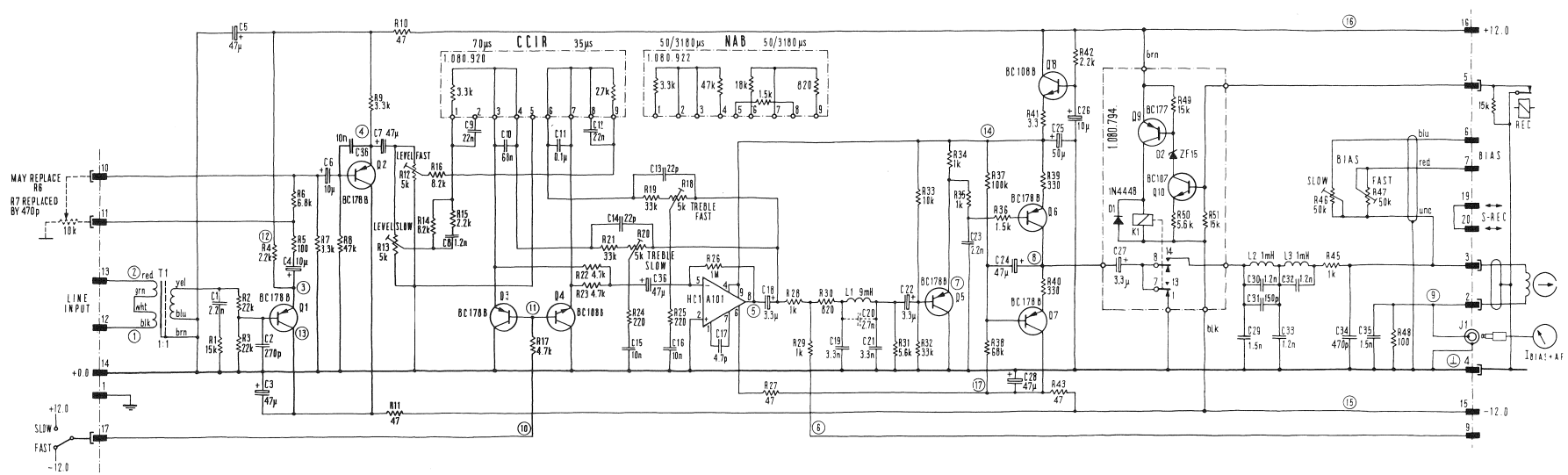

Input 1500 mV, 1 kHz Position "FAST"

TEST POINTS

	1	2	3	4	5	6	7	8	9	10	11	12	13	14	15	16	17
mV ~	1500	750	225	430	340	270	820	70	—	—	—	—	—	—	—	—	—
V =	—	+0.8	+1	-0.5	—	+9.2	-0.5	—	-12	-0.7	+11.6	-11.6	+11.2	-12	-12	-11.6	—

AC-voltmeter, min. 100 kΩ

DC-voltmeter, min. 40 kΩ/V

RECORD AMPLIFIER 1.080.982

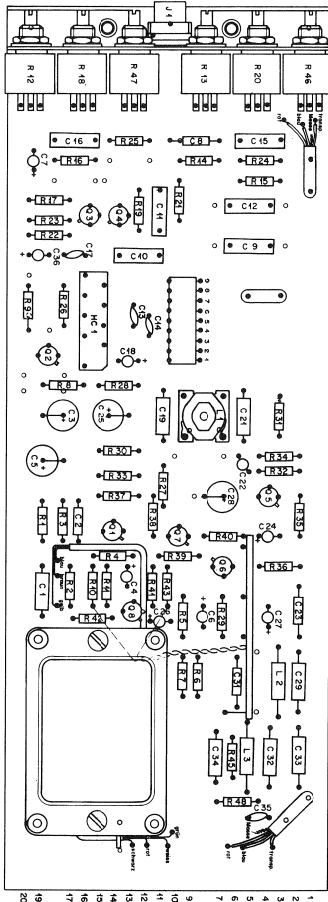

IDENTIFICATION	PART NAME	TYPE / REMARKS	Specifications	ORDER NUMBER
	Record Amplifier	Board assembled		1.080.982
C 1	Capacitor	polystyrol	2,2 nF - 5% - 25 V	**
C 2	Capacitor	polystyrol	270 pF - 5% - 25 V	**
C 3	Capacitor	electrolytic	47 µF - 50% - 35 V	**
C 4	Capacitor	tantalum	10 µF - 50% - 16 V	**
C 5	Capacitor	electrolytic	47 µF - 50% - 35 V	**
C 6	Capacitor	tantalum	10 µF - 50% - 16 V	**
C 7	Capacitor	tantalum	47 µF - 50% - 3 V	**
C 8	Capacitor	polystyrol	1,2 nF - 5% - 25 V	**
C 9	Capacitor	polyester	0,022 µF - 10% - 250 V	**
C 10	Capacitor	polyester	68 nF - 10% - 100 V	**
C 11	Capacitor	polyester	0,1 µF - 10% - 160 V	**
C 12	Capacitor	polyester	0,022 µF - 10% - 250 V	**
C 13	Capacitor	ceramic	22 pF - 20% - 500 V	**
C 14	Capacitor	ceramic	22 pF - 20% - 500 V	**
C 15	Capacitor	polyester	0,01 µF - 10% - 160 V	**
C 16	Capacitor	polyester	0,01 µF - 10% - 160 V	**
C 17	Capacitor	ceramic	4,7 pF - 5% - 50 V	**
C 18	Capacitor	tantalum	3,3 µF - 50% - 35 V	**
C 19	Capacitor	polystyrol	3,3 nF - 5% - 25 V	**
C 21	Capacitor	polystyrol	3,3 nF - 5% - 25 V	**
C 22	Capacitor	tantalum	3,3 µF - 50% - 35 V	**
C 23	Capacitor	polystyrol	2,2 nF - 5% - 25 V	**
C 24	Capacitor	tantalum	47 µF - 50% - 3 V	**
C 25	Capacitor	electrolytic	47 µF - 50% - 35 V	**
C 26	Capacitor	tantalum	10 µF - 50% - 16 V	**
C 27	Capacitor	tantalum	3,3 µF - 50% - 35 V	**
C 28	Capacitor	electrolytic	47 µF - 50% - 35 V	**
C 29	Capacitor	ceramic	1,5 nF - 10% - 500 V	**
C 30	Capacitor	polystyrol	1,2 nF - 5% - 160 V	**
C 31	Capacitor	polystyrol	150 pF - 5% - 160 V	**
C 32	Capacitor	polystyrol	1,2 nF - 5% - 160 V	**
C 33	Capacitor	polystyrol	1,2 nF - 5% - 160 V	**
C 34	Capacitor	polystyrol	470 pF - 5% - 63 V	**
C 35	Capacitor	polystyrol	1,5 nF - 5% - 160 V	**
C 38	Capacitor	ceramic	10 nF - 80% - 50 V	**
HC 1	Hybrid Circuit	A 101	4 dB	1.010.101.50
J 1	Jack-Socket			54.02.0106
L 1	Choke Coil		9 mH	1.022.128
L 2	Choke Coil		1 mH	62.01.0114
L 3	Choke Coil		1 mH	62.01.0114
Q 1	Transistor	BC 178 B		**

IDENTIFICATION	PART NAME	TYPE / REMARKS	Specifications	ORDER NUMBER
R 42	Resistor	carbon film	2,2 k	**
R 43	Resistor	carbon film	47	**
R 44	Resistor	carbon film	47 k	**
R 45	Resistor	carbon film	1 k	**
R 46	Potentiometer	carbon composition	50 k - 10% - 0,5 W	**
R 47	Potentiometer	carbon composition	50 k - 10% - 0,5 W	**
R 48	Resistor	carbon film	100	**
T 1	Input-Transformer		1 : 1	1.022.302
TP 1	Connector			54.01.0212

IDENTIFICATION	PART NAME	TYPE / REMARKS	Specifications	ORDER NUMBER
O 2	Transistor	BC 178 B		**
O 3	Transistor	BC 178 B		**
O 4	Transistor	BC 108 B		**
O 5	Transistor	BC 178 B		**
O 6	Transistor	BC 178 B		**
O 7	Transistor	BC 178 B		**
O 8	Transistor	BC 108 B		**
R 1	Resistor	carbon film	15 k	**
R 2	Resistor	carbon film	22 k	**
R 3	Resistor	carbon film	22 k	**
R 4	Resistor	carbon film	2,2 k	**
R 5	Resistor	carbon film	100	**
R 6	Resistor	carbon film	1,8 k	**
R 7	Resistor	carbon film	3,3 k	**
R 8	Resistor	carbon film	47 k	**
R 9	Resistor	carbon film	3,3 k	**
R 10	Resistor	carbon film	47	**
R 11	Resistor	carbon film	47	**
R 12	Potentiometer	carbon film	5 k - 10% - 0,5 W	**
R 13	Potentiometer	carbon film	5 k - 10% - 0,5 W	**
R 14	Resistor	carbon film	8,2 k	**
R 15	Resistor	carbon film	2,2 k	**
R 16	Resistor	carbon film	8,2 k	**
R 17	Resistor	carbon film	4,7 k	**
R 18	Potentiometer	carbon film	5 k - 10% - 0,5 W	**
R 19	Resistor	carbon film	33 k	**
R 20	Potentiometer	carbon film	5 k - 10% - 0,5 W	**
R 21	Resistor	carbon film	33 k	**
R 22	Resistor	carbon film	4,7 k	**
R 23	Resistor	carbon film	4,7 k	**
R 24	Resistor	carbon film	220	**
R 25	Resistor	carbon film	220	**
R 26	Resistor	carbon film	1 M	**
R 27	Resistor	carbon film	47	**
R 28	Resistor	carbon film	1 k	**
R 29	Resistor	carbon film	1 k	**
R 30	Resistor	carbon film	820	**
R 31	Resistor	carbon film	5,6 k	**
R 32	Resistor	carbon film	33 k	**
R 33	Resistor	carbon film	10 k	**
R 34	Resistor	carbon film	1 k	**
R 35	Resistor	carbon film	1 k	**
R 36	Resistor	carbon film	1,5 k	**
R 37	Resistor	carbon film	300 k	**
R 38	Resistor	carbon film	88 k	**
R 39	Resistor	carbon film	330	**
R 40	Resistor	carbon film	330	**
R 41	Resistor	carbon film	3,3	**

OSCILLATOR STEREO 1.080.984

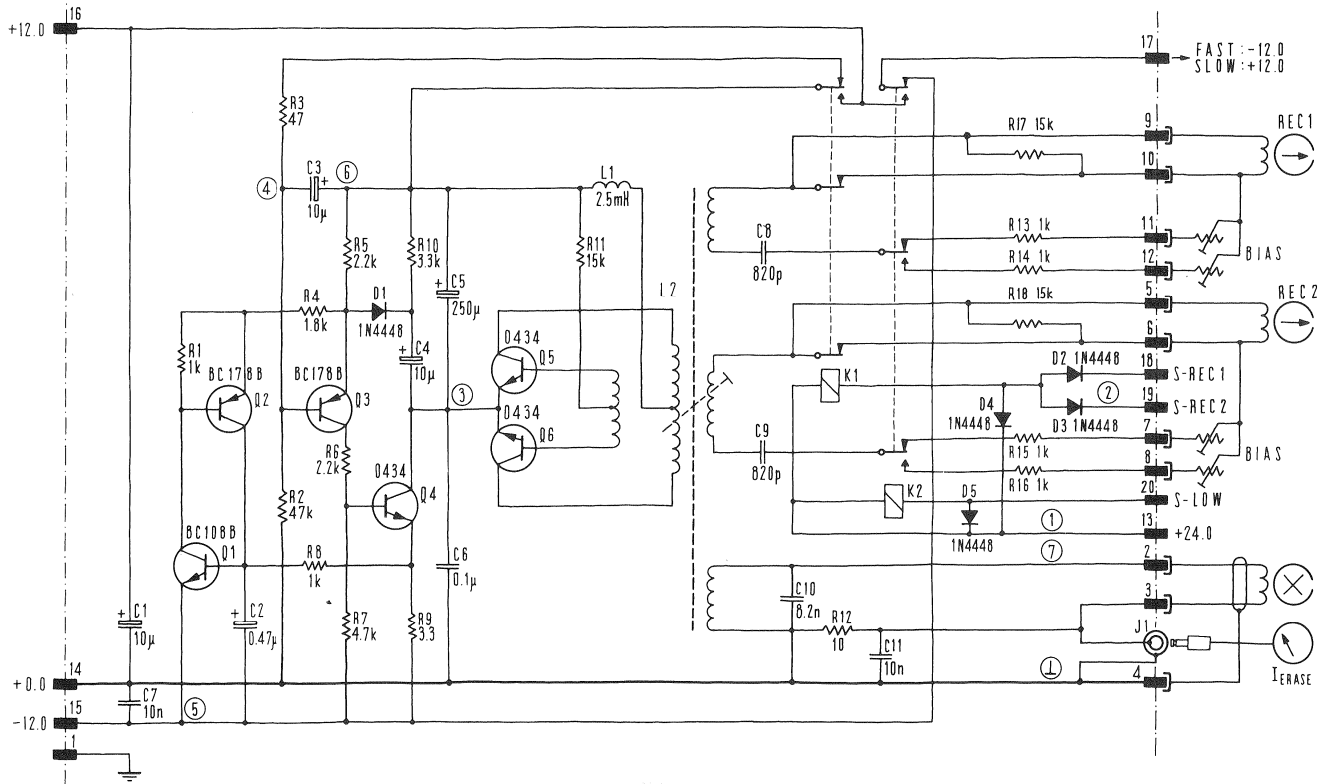

Position "FAST"

TEST POINTS	1	2	3	4	5	6	7	
V =	+ 24	-	-11.6	0.5	-12	+12	-	
							V~	96V
							150 kHz	AC-voltmeter, min. 1 MΩ

DC-voltmeter, min. 100 kΩ

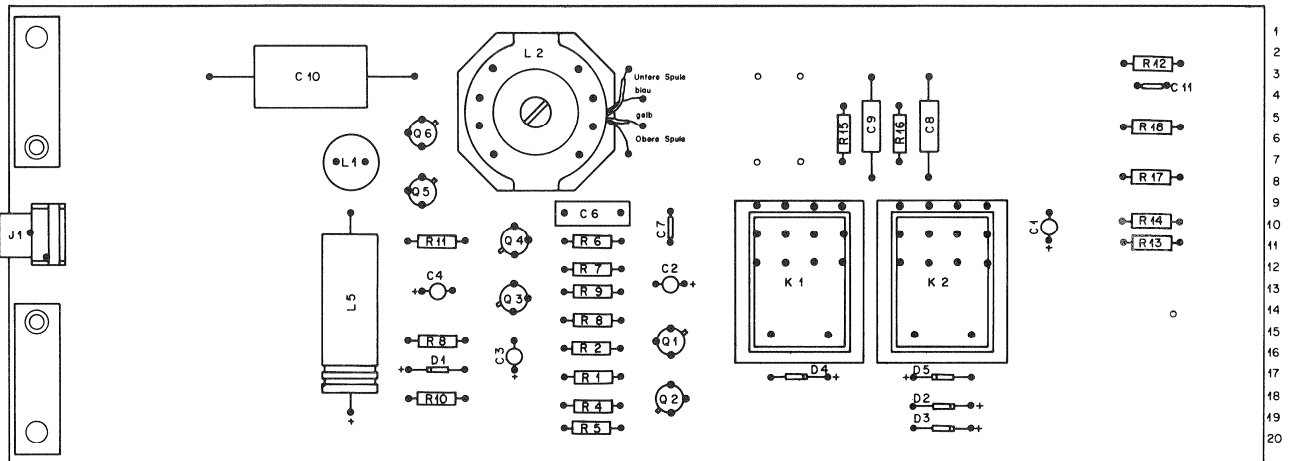

REPRODUCE AMPLIFIER 1.080.986-1

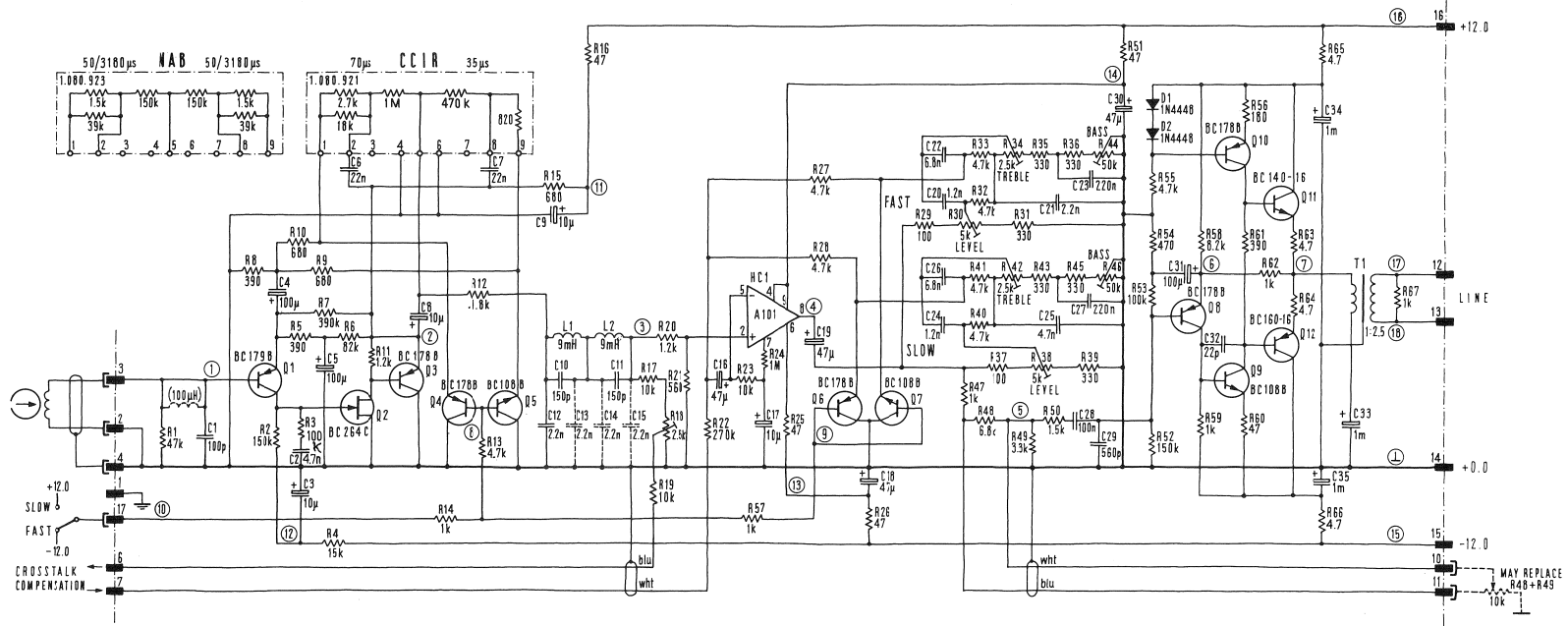

Input 3 mV, 1 kHz Position "FAST"

TEST POINTS	1	2	3	4	5	6	7	8	9	10	11	12	13	14	15	16	17	18
mV~	3	140	65	500	380	380	1200	—	—	—	—	—	—	—	—	—	—	3000
V =	—	+4.8	—	+0.8	—	+0.8	+0.2	-0.7	-0.7	-12	+11.8	-10.8	-11.6	+11.6	-12	+12	—	—

AC-voltmeter, min. 100 kΩ
DC-voltmeter, min. 40 kΩ/V.

REPRODUCE AMPLIFIER 1.080.986-1

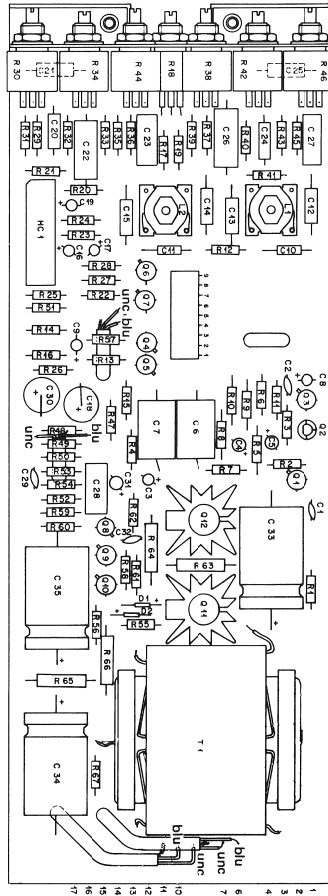

IDENTIFICATION	PART NAME	TYPE / REMARKS	Unspecified carbon film resistors: 1/8 W - 5%	
			SPECIFICATIONS	ORDER NUMBER
	Reproduce Amplifier	Board assembled		1.080.986
C 1	Capacitor	ceramic	100 pF - 20% - 500 V	**
C 2	Capacitor	ceramic	1.7 nF - 80% - 25 V	**
C 3	Capacitor	tantalum	10 pF - 50% - 16 V	**
C 4	Capacitor	tantalum	100 pF - 50% - 3 V	**
C 5	Capacitor	tantalum	100 pF - 50% - 3 V	**
C 6	Capacitor	polystyrol	22 nF - 1% - 63 V	**
C 7	Capacitor	polystyrol	22 nF - 1% - 63 V	**
C 8	Capacitor	tantalum	10 pF - 50% - 16 V	**
C 9	Capacitor	tantalum	10 pF - 50% - 16 V	**
C 10	Capacitor	polystyrol	50 pF - 5% - 63 V	**
C 11	Capacitor	polystyrol	50 pF - 5% - 63 V	**
C 12	Capacitor	polystyrol	2.2 nF - 5% - 25 V	**
C 13	Capacitor	polystyrol	2.2 nF - 5% - 25 V	**
C 14	Capacitor	polystyrol	2.2 nF - 5% - 25 V	**
C 15	Capacitor	polystyrol	2.2 nF - 5% - 25 V	**
C 16	Capacitor	tantalum	47 pF - 50% - 3 V	**
C 17	Capacitor	tantalum	10 pF - 50% - 16 V	**
C 18	Capacitor	elektrolytic	47 pF - 50% - 35 V	**
C 19	Capacitor	tantalum	47 pF - 60% - 3 V	**
C 20	Capacitor	polystyrol	1.2 nF - 5% - 25 V	**
C 21	Capacitor	polystyrol	2.2 nF - 5% - 25 V	**
C 22	Capacitor	polystyrol	6.8 nF - 2% - 63 V	**
C 23	Capacitor	polyester	0.22 pF - 10% - 100 V	**
C 24	Capacitor	polystyrol	1.2 nF - 5% - 25 V	**
C 25	Capacitor	polystyrol	4.7 nF - 5% - 25 V	**
C 26	Capacitor	polystyrol	6.8 nF - 2% - 63 V	**
C 27	Capacitor	polyester	0.22 pF - 10% - 100 V	**
C 28	Capacitor	polyester	0.1 pF - 10% - 100 V	**
C 29	Capacitor	ceramic	980 pF - 20% - 500 V	**
C 30	Capacitor	elektrolytic	47 pF - 50% - 35 V	**
C 31	Capacitor	tantalum	100 pF - 50% - 3 V	**
C 32	Capacitor	ceramic	22 pF - 20% - 500 V	**
C 33	Capacitor	elektrolytic	1000 pF - 50% - 18 V	**
C 34	Capacitor	elektrolytic	1000 pF - 50% - 18 V	**
C 35	Capacitor	elektrolytic	1000 pF - 50% - 18 V	**
D 1	Diode	1 N 444B		**
D 2	Diode	1 N 444B		**
HC 1	Hybrid - Circuit	A 101	4 dB	1.010.101.50
L 1	Choke coil	9 mH		1.022.128
L 2	Choke coil	9 mH		1.022.128

IDENTIFICATION	PART NAME	TYPE / REMARKS	Unspecified carbon film resistors: 1/8 W - 5%	
			SPECIFICATIONS	ORDER NUMBER
R 36	Resistor	carbon film	330	**
R 37	Resistor	carbon film	100	**
R 38	Potentiometer	carbon composition	5 k - 10% - 0.5 W	**
R 39	Resistor	carbon film	330	**
R 40	Resistor	carbon film	4.7 k	**
R 41	Resistor	carbon film	4.7 k	**
R 42	Potentiometer	carbon film	2.5 k - 10% - 0.5 W	**
R 43	Resistor	carbon film	330	**
R 44	Potentiometer	carbon composition	50 k - 10% - 0.5 W	**
R 45	Resistor	carbon film	330	**
R 46	Potentiometer	carbon composition	50 k - 10% - 0.5 W	**
R 47	Resistor	carbon film	1 k	**
R 48	Resistor	carbon film	6.8 k	**
R 49	Resistor	carbon film	3.3 k	**
R 50	Resistor	carbon film	1.5 k	**
R 51	Resistor	carbon film	47	**
R 52	Resistor	carbon film	150 k	**
R 53	Resistor	carbon film	100 k	**
R 54	Resistor	carbon film	470	**
R 55	Resistor	carbon film	4.7 k	**
R 56	Resistor	carbon film	180	**
R 57	Resistor	carbon film	1 k	**
R 58	Resistor	carbon film	8.2 k	**
R 59	Resistor	carbon film	1 k	**
R 60	Resistor	carbon film	47	**
R 61	Resistor	carbon film	390	**
R 62	Resistor	carbon film	1 k	**
R 63	Resistor	carbon film	4.7 - 5% - 0.33 W	**
R 64	Resistor	carbon film	4.7 - 5% - 0.33 W	**
R 65	Resistor	carbon film	4.7 - 5% - 0.33 W	**
R 66	Resistor	carbon film	4.7 - 5% - 0.33 W	**
R 67	Resistor	carbon film	1 k	**

IDENTIFICATION	PART NAME	TYPE / REMARKS	Unspecified carbon film resistors: 1/8 W - 5%	
			SPECIFICATIONS	ORDER NUMBER
Q 1	Transistor	BC 179 B		**
Q 2	FTT	BC 294 C		**
Q 3	Transistor	BC 178 B		**
Q 4	Transistor	BC 178 B		**
Q 5	Transistor	BC 108 B		**
Q 6	Transistor	BC 178 B		**
Q 7	Transistor	BC 108 B		**
Q 8	Transistor	BC 178 B		**
Q 9	Transistor	BC 108 B		**
Q 10	Transistor	BC 178 B		**
Q 11	Transistor	BC 140-16		**
Q 12	Transistor	BC 160-16		**
R 1	Resistor	carbon film	47 k	**
R 2	Resistor	carbon film	150 k	**
R 3	Resistor	carbon film	100 k	**
R 4	Resistor	carbon film	15 k	**
R 5	Resistor	metal film	300 - 1% - 0.33 W	**
R 6	Resistor	carbon film	82 k	**
R 7	Resistor	carbon film	300 k	**
R 8	Resistor	metal film	300 - 1% - 0.33 W	**
R 9	Resistor	metal film	680 - 1% - 0.33 W	**
R 10	Resistor	metal film	680 - 1% - 0.33 W	**
R 11	Resistor	carbon film	1.2 k	**
R 12	Resistor	carbon film	1.8 k	**
R 13	Resistor	carbon film	4.7 k	**
R 14	Resistor	carbon film	1 k	**
R 15	Resistor	carbon film	680	**
R 16	Resistor	carbon film	47	**
R 17	Resistor	carbon film	10 k	**
R 18	Potentiometer	carbon film	2.5 k - 10% - 0.5 W	**
R 19	Resistor	carbon film	10 k	**
R 20	Resistor	carbon film	1.2 k	**
R 21	Resistor	carbon film	560	**
R 22	Resistor	carbon film	270 k	**
R 23	Resistor	carbon film	10 k	**
R 24	Resistor	carbon film	1 M	**
R 25	Resistor	carbon film	47	**
R 26	Resistor	carbon film	47	**
R 27	Resistor	carbon film	4.7 k	**
R 28	Resistor	carbon film	4.7 k	**
R 29	Resistor	carbon film	180	**
R 30	Potentiometer	carbon composition	5 k - 10% - 0.5 W	**
R 31	Resistor	carbon film	330	**
R 32	Resistor	carbon film	4.7 k	**
R 33	Resistor	carbon film	4.7 k	**
R 34	Potentiometer	carbon film	2.5 k - 10% - 0.5 W	**
R 35	Resistor	carbon film	330	**

OSCILLATOR 2-TRACK 1.080.987

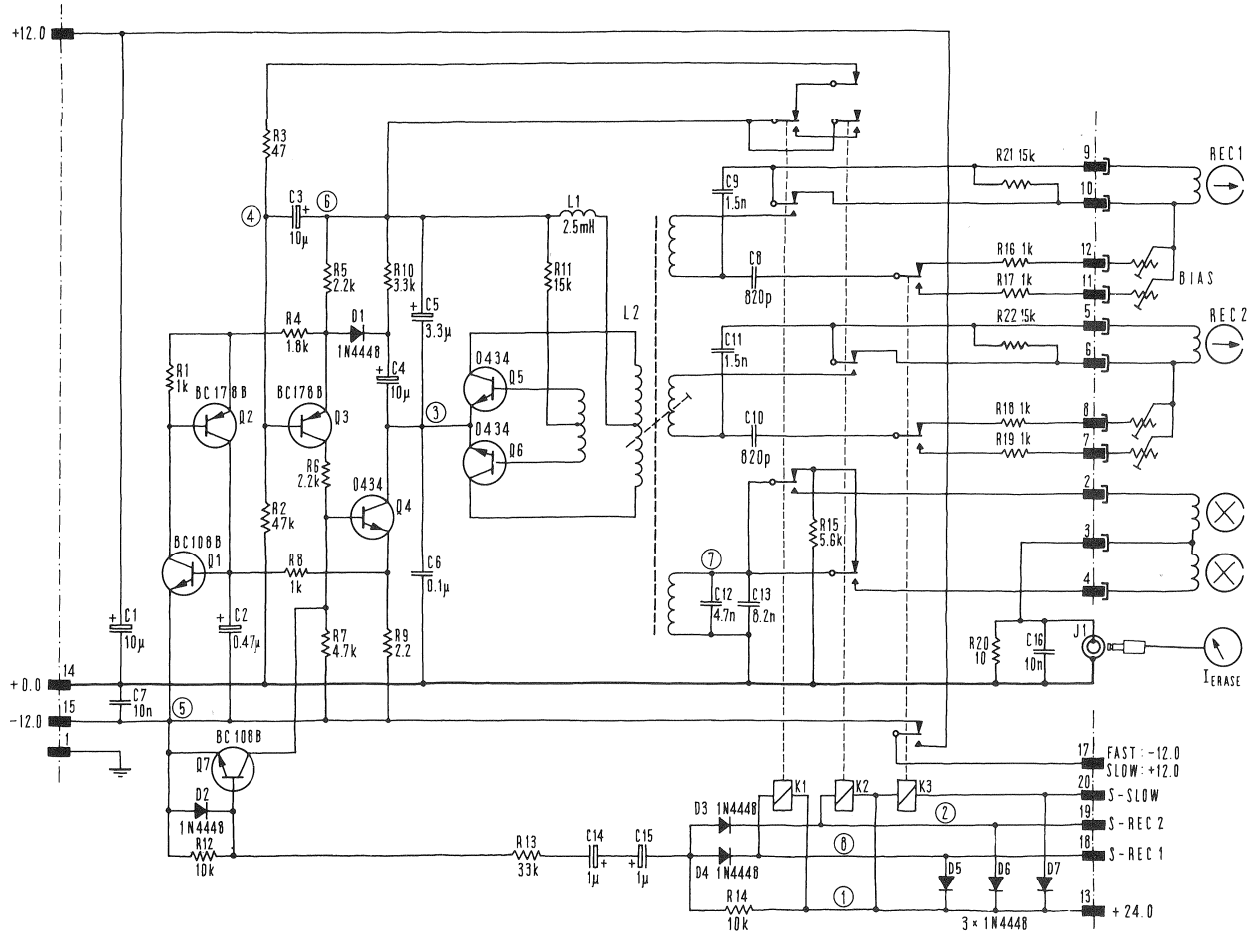

Position "FAST"

TEST POINTS

1	2	3	4	5	6	7	8
+	(24)	-	-11.6	0.5	-12	+12	-(24)

DC-voltmeter, min. 100 kΩ

V~
150 kHz
96V

AC-voltmeter, min. 1 MΩ

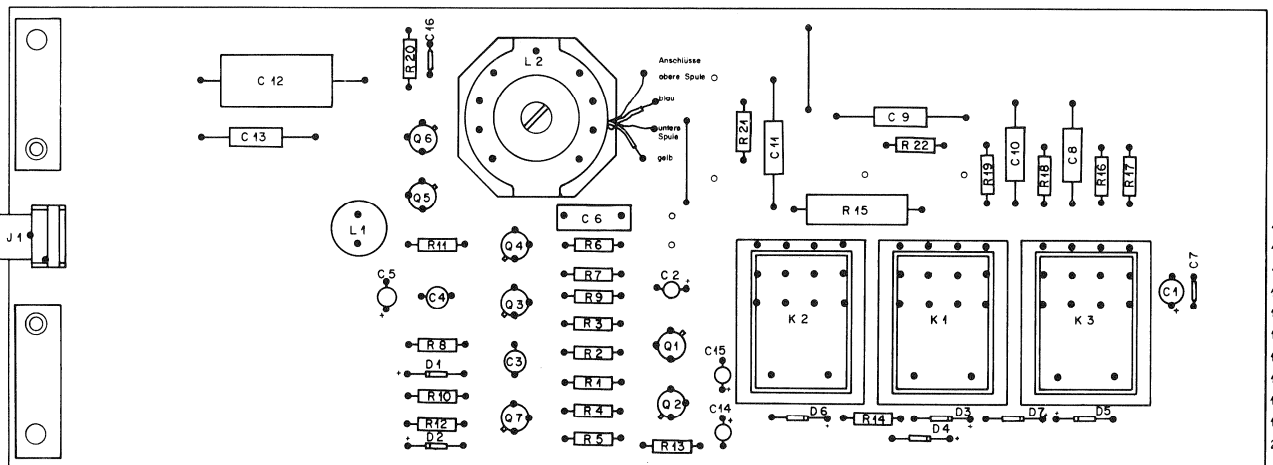

STABILIZER 1.080.988

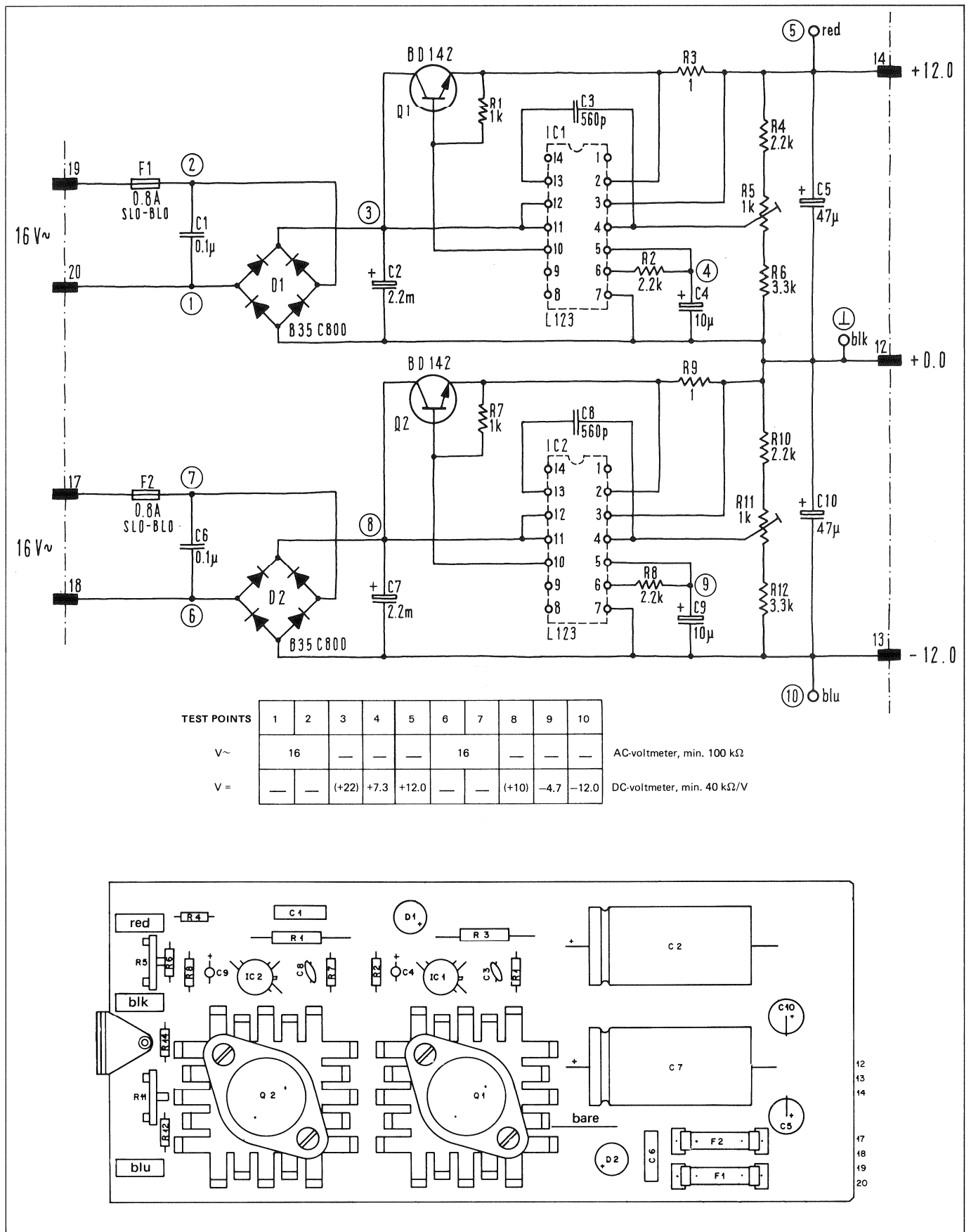

TEST POINTS	1	2	3	4	5	6	7	8	9	10	
V~	16	—	—	—	—	16	—	—	—	—	AC-voltmeter, min. 100 kΩ
V =	—	—	(+22)	+7.3	+12.0	—	—	(+10)	-4.7	-12.0	DC-voltmeter, min. 40 kΩ/V

STABILIZER 1.080.988

IDENTIFICATION	PART NAME	TYPE / REMARKS	Unspecified carbon film resistors: 1/8 W - 5%	** Commercial types
			SPECIFICATIONS	ORDER NUMBER
	Stabilizer	board assembled		1.080.988
C 1	Capacitor	polyester	0,1 μ F - 20 % - 160 V	* *
C 2	Capacitor	elektrolytic	2200 μ F - 50 % - 25 V	* *
C 3	Capacitor	ceramic	560 pF - 20 % - 500 V	* *
C 4	Capacitor	tantalum	10 μ F - 50 % - 16 V	* *
C 5	Capacitor	elektrolytic	47 μ F - 50 % - 35 V	* *
C 6	Capacitor	polyester	0,1 μ F - 20 % - 160 V	* *
C 7	Capacitor	elektrolytic	2200 μ F - 50 % - 25 V	* *
C 8	Capacitor	ceramic	560 pF - 20 % - 500 V	* *
C 9	Capacitor	tantalum	10 μ F - 50 % - 16 V	* *
C 10	Capacitor	elektrolytic	47 μ F - 50 % - 35 V	* *
D 1	Rectifier	B 35 C 800		* *
D 2	Rectifier	B 35 C 800		* *
F 1	Fuse		800 mA T	* *
F 2	Fuse		800 mA T	* *
IC 1	Integrated Circuit	μ A 723	Voltage regulator	* *
IC 2	Integrated Circuit	μ A 723	Voltage regulator	* *
Q 1	Transistor	BD 142 - 5 L		* *
Q 2	Transistor	BD 142 - 5 L		* *
R 1	Resistor	carbon film	1 k	* *
R 2	Resistor	carbon film	2,2 k	* *
R 3	Resistor	wire - wound	1 - 10 % - 2 W	* *
R 4	Resistor	carbon film	2,2 k	* *
R 5	Potentiometer	carbon film	1 k - 20 % - 0,15 W	* *
R 6	Resistor	carbon film	3,3 k	* *
R 7	Resistor	carbon film	1 k	* *
R 8	Resistor	carbon film	2,2 k	* *
R 9	Resistor	wire - wound	1 - 10 % - 2 W	* *
R 10	Resistor	carbon film	2,2 k	* *
R 11	Potentiometer	carbon film	1 k - 20 % - 0,15 W	* *
R 12	Resistor	carbon film	3,3 k	* *

MONO / STEREO SWITCH 1.080.994

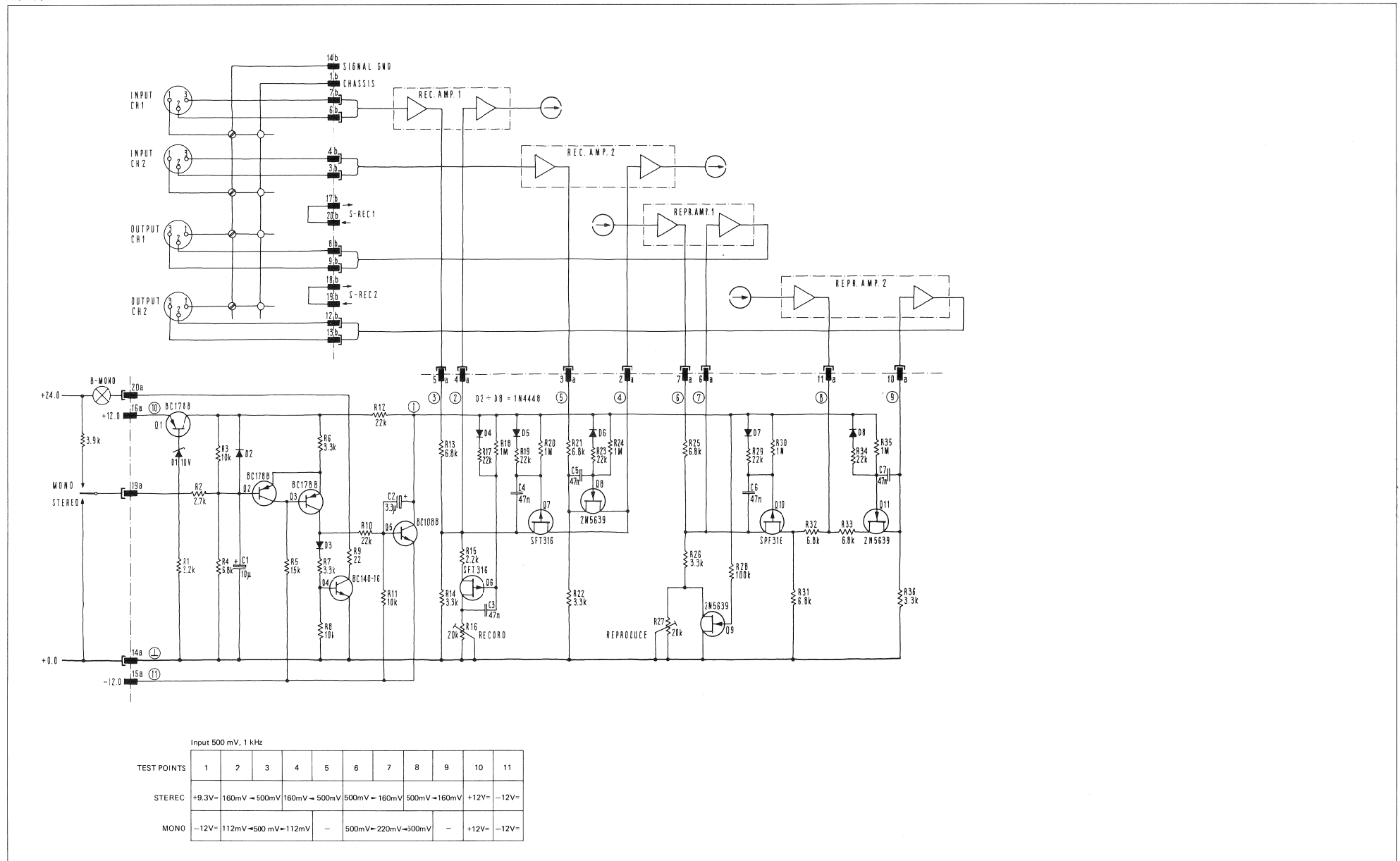

MONO / STEREO SWITCH 1.080.994

IDENTIFICATION	PART NAME	TYPE / REMARKS	Unspecified carbon film resistor: 10 W - 5%	
			SPECIFICATIONS	ORDER NUMBER
	MONO/STEREO Switch	Board assembled		1.080.994
C 1	Capacitor	tantalum	10 μ F - 50% - 16 V	* *
C 2	Capacitor	tantalum	3,3 μ F - 50% - 35 V	* *
C 3	Capacitor	polyester	0,047 μ F - 20% - 160 V	* *
C 4	Capacitor	polyester	0,047 μ F - 20% - 160 V	* *
C 5	Capacitor	polyester	0,047 μ F - 20% - 160 V	* *
C 6	Capacitor	polyester	0,047 μ F - 20% - 160 V	* *
C 7	Capacitor	polyester	0,047 μ F - 20% - 160 V	* *
D 1	Zener - Diode		10 V - 5% - 0,4 W	* *
D 2	Si - Diode	1 N 4448		* *
D 3	Si - Diode	1 N 4448		* *
D 4	Si - Diode	1 N 4448		* *
D 5	Si - Diode	1 N 4448		* *
D 6	Si - Diode	1 N 4448		* *
D 7	Si - Diode	1 N 4448		* *
D 8	Si - Diode	1 N 4448		* *
Q 1	Transistor	8C 178 B		* *
Q 2	Transistor	8C 178 B		* *
Q 3	Transistor	8C 178 B		* *
Q 4	Transistor	8C 140 - 10		* *
Q 5	Transistor	8C 168 B		* *
Q 6	FET	P 1087 E		* *
Q 7	FET	P 1087 E		* *
Q 8	FET	2 N 5039		* *
Q 9	FET	2 N 5039		* *
Q 10	FET	P 1087 E		* *
Q 11	FET	2 N 5039		* *
R 1	Resistor	carbon film	2,2 k	* *
R 2	Resistor	carbon film	2,7 k	* *
R 3	Resistor	carbon film	10 k	* *
R 4	Resistor	carbon film	6,8 k	* *
R 5	Resistor	carbon film	15 k	* *
R 6	Resistor	carbon film	3,3 k	* *
R 7	Resistor	carbon film	3,3 k	* *
R 8	Resistor	carbon film	10 k	* *
R 9	Resistor	carbon film	22	* *
R 10	Resistor	carbon film	22 k	* *
R 11	Resistor	carbon film	10 k	* *
R 12	Resistor	carbon film	22 k	* *
R 13	Resistor	carbon film	6,8 k	* *
R 14	Resistor	carbon film	3,3 k	* *
R 15	Resistor	carbon film	2,2 k	* *
R 16	Potentiometer	carbon film	20 k - 20% - 0,25 W	* *

IDENTIFICATION	PART NAME	TYPE / REMARKS	Unspecified carbon film resistor: 10 W - 5%	
			SPECIFICATIONS	ORDER NUMBER
R 17	Resistor	carbon film	22 k	* *
R 18	Resistor	carbon film	1 M	* *
R 19	Resistor	carbon film	22 k	* *
R 20	Resistor	carbon film	1 M	* *
R 21	Resistor	carbon film	6,8 k	* *
R 22	Resistor	carbon film	3,3 k	* *
R 23	Resistor	carbon film	22 k	* *
R 24	Resistor	carbon film	1 M	* *
R 25	Resistor	carbon film	6,8 k	* *
R 26	Resistor	carbon film	3,3 k	* *
R 27	Potentiometer	carbon film	20 k - 20% - 0,25 W	* *
R 28	Resistor	carbon film	100 k	* *
R 29	Resistor	carbon film	22 k	* *
R 30	Resistor	carbon film	1 M	* *
R 31	Resistor	carbon film	6,8 k	* *
R 32	Resistor	carbon film	6,8 k	* *
R 33	Resistor	carbon film	6,8 k	* *
R 34	Resistor	carbon film	22 k	* *
R 35	Resistor	carbon film	1 M	* *
R 36	Resistor	carbon film	3,3 k	* *

MONO-STEREO SWITCH 1.080.994

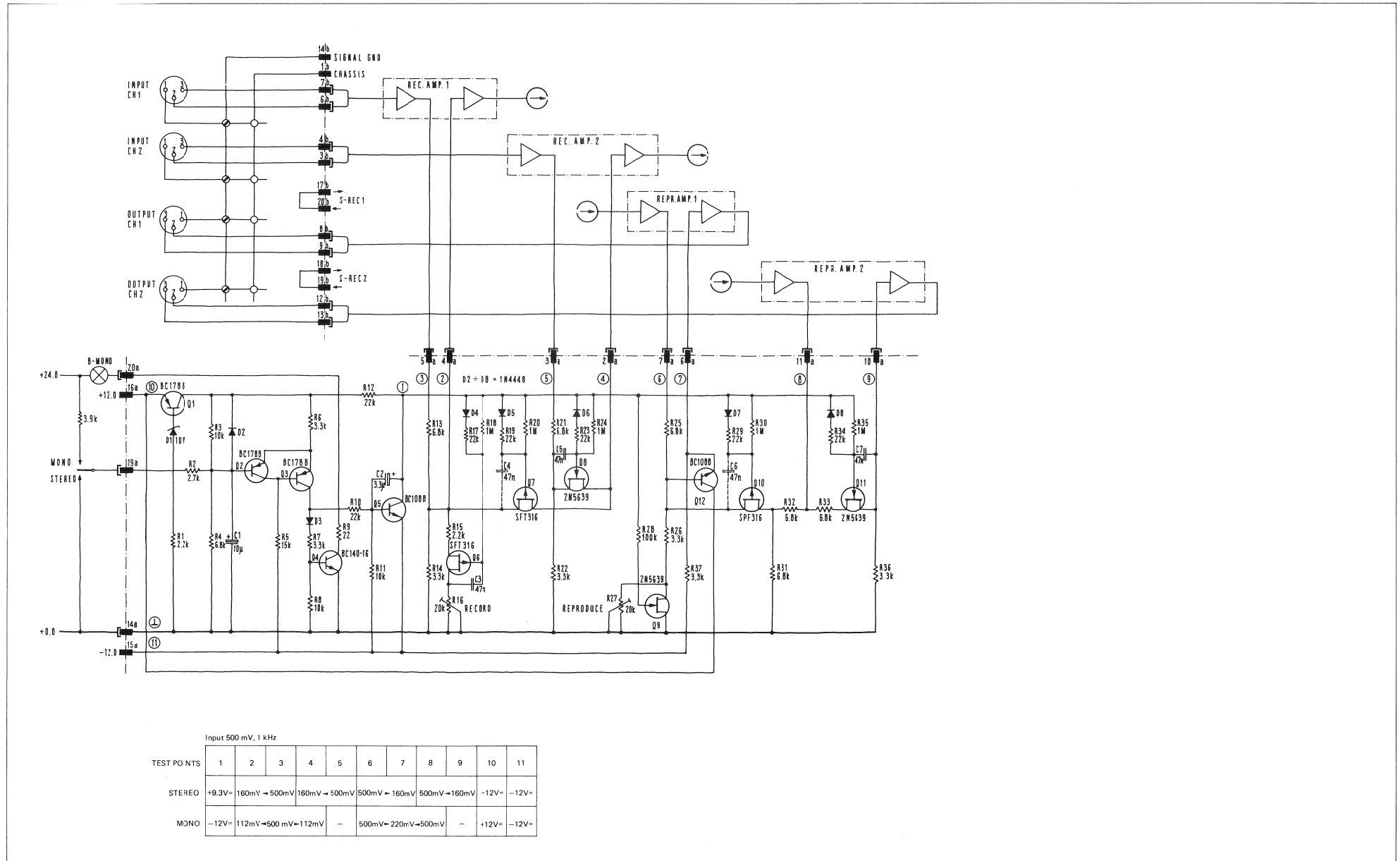

MONO-STEREO SWITCH 1.080.994

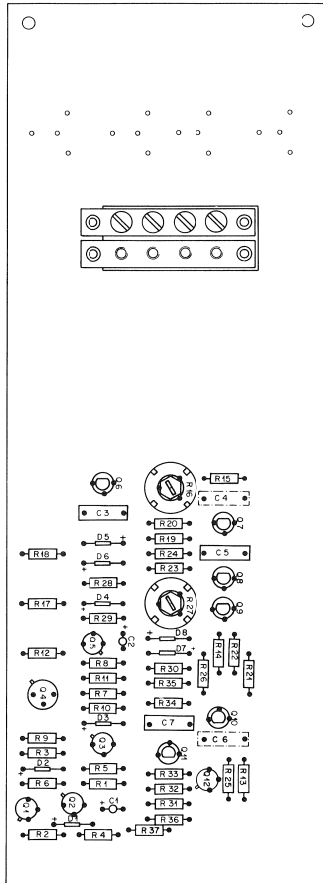

IDENTIFICATION	PART NAME	TYPE / REMARKS	SPECIFICATIONS	ORDER NUMBER
	MONO/STEREO Switch	Board assembled		1.080.994
C 1	Capacitor	tantalum	10 μ F - 50% - 16 V	* *
C 2	Capacitor	tantalum	3,3 μ F - 50% - 35 V	* *
C 3	Capacitor	polyester	0047 μ F - 20% - 160 V	* *
C 4	Capacitor	polyester	0047 μ F - 20% - 160 V	* *
C 5	Capacitor	polyester	0047 μ F - 20% - 160 V	* *
C 6	Capacitor	polyester	0047 μ F - 20% - 160 V	* *
C 7	Capacitor	polyester	0047 μ F - 20% - 160 V	* *
D 1	Zener - Diode		10 V - 5% - 0,4 W	* *
D 2	Si - Diode	1 N 4448		* *
D 3	Si - Diode	1 N 4448		* *
D 4	Si - Diode	1 N 4448		* *
D 5	Si - Diode	1 N 4448		* *
D 6	Si - Diode	1 N 4448		* *
D 7	Si - Diode	1 N 4448		* *
D 8	Si - Diode	1 N 4448		* *
Q 1	Transistor	8C 178 B		* *
Q 2	Transistor	8C 178 B		* *
Q 3	Transistor	8C 178 B		* *
Q 4	Transistor	8C 140 - 10		* *
Q 5	Transistor	8C 108 B		* *
Q 6	FET	P 1087 E		* *
Q 7	FET	P 1087 E		* *
Q 8	FET	2 N 5639		* *
Q 9	FET	2 N 5639		* *
Q 10	FET	P 1087 E		* *
Q 11	FET	2 N 5639		* *
Q 12	Transistor	8C 108 B		* *
R 1	Resistor	carbon film	2,2 k	* *
R 2	Resistor	carbon film	2,7 k	* *
R 3	Resistor	carbon film	10 k	* *
R 4	Resistor	carbon film	6,8 k	* *
R 5	Resistor	carbon film	15 k	* *
R 6	Resistor	carbon film	3,3 k	* *
R 7	Resistor	carbon film	3,3 k	* *
R 8	Resistor	carbon film	10 k	* *
R 9	Resistor	carbon film	22 k	* *
R 10	Resistor	carbon film	22 k	* *
R 11	Resistor	carbon film	10 k	* *
R 12	Resistor	carbon film	22 k	* *
R 13	Resistor	carbon film	6,8 k	* *
R 14	Resistor	carbon film	3,3 k	* *
R 15	Resistor	carbon film	2,2 k	* *

IDENTIFICATION	PART NAME	TYPE / REMARKS	SPECIFICATIONS	ORDER NUMBER
R 16	Potentiometer	carbon film	20 k - 20% - 0,25 W	* *
R 17	Resistor	carbon film	22 k	* *
R 18	Resistor	carbon film	1 M	* *
R 19	Resistor	carbon film	22 k	* *
R 20	Resistor	carbon film	1 M	* *
R 21	Resistor	carbon film	6,8 k	* *
R 22	Resistor	carbon film	3,3 k	* *
R 23	Resistor	carbon film	22 k	* *
R 24	Resistor	carbon film	1 M	* *
R 25	Resistor	carbon film	6,8 k	* *
R 26	Resistor	carbon film	3,3 k	* *
R 27	Potentiometer	carbon film	20 k - 20% - 0,25 W	* *
R 28	Resistor	carbon film	100 k	* *
R 29	Resistor	carbon film	22 k	* *
R 30	Resistor	carbon film	1 M	* *
R 31	Resistor	carbon film	6,8 k	* *
R 32	Resistor	carbon film	6,8 k	* *
R 33	Resistor	carbon film	6,8 k	* *
R 34	Resistor	carbon film	22 k	* *
R 35	Resistor	carbon film	1 M	* *
R 36	Resistor	carbon film	3,3 k	* *
R 37	Resistor	carbon film	3,3 k	* *

PILOT TONE AMPLIFIER 1.080.996

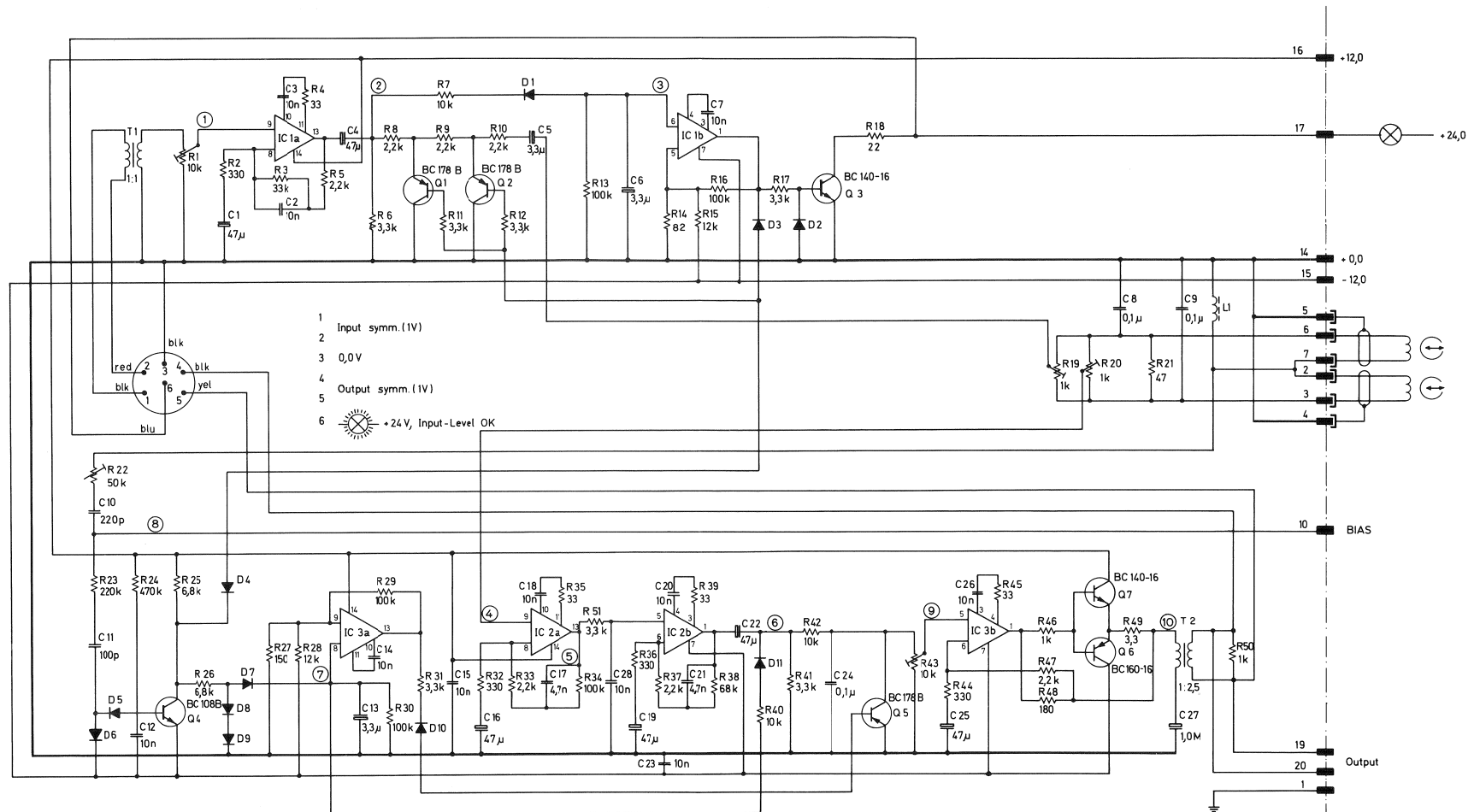

- 1 Input symm. (IV)
- 2 0,0V
- 3 0,0V
- 4 Output symm. (IV)
- 5
- 6 +24 V, Input-Level OK

TEST POINTS	1	2	3	4	5	6	7	8	9	10
mV ~ 50 Hz	15	1500	-	0.04	12	2400	-	150kHz: 94 V	52	400
V =	-	-	-0.7	-	0.2	-	-1.2	-	-	-

PILOT TONE AMPLIFIER 1.080.996

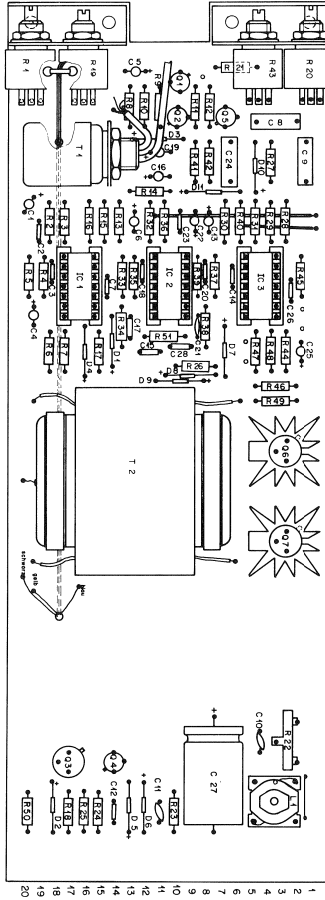

IDENTIFICATION	PART NAME	TYPE / REMARKS	SPECIFICATIONS	ORDER NUMBER
	Pilot Tone Amplifier	Board assembled		1.080.996
C 1	Capacitor	tantalum	47 μ F - 50% - 3 V	*
C 2	Capacitor	ceramic	10 nF - 80% - 50 V	*
C 3	Capacitor	ceramic	10 nF - 80% - 50 V	*
C 4	Capacitor	tantalum	47 μ F - 50% - 3 V	*
C 5	Capacitor	tantalum	3,3 μ F - 50% - 35 V	*
C 6	Capacitor	tantalum	3,3 μ F - 50% - 35 V	*
C 7	Capacitor	ceramic	10 nF - 80% - 50 V	*
C 8	Capacitor	polyester	0,1 μ F - 10% - 160 V	*
C 9	Capacitor	polyester	0,1 μ F - 10% - 160 V	*
C 10	Capacitor	ceramic	220 μ F - 20% - 500 V	*
C 11	Capacitor	ceramic	100 pF - 20% - 500 V	*
C 12	Capacitor	ceramic	10 nF - 80% - 50 V	*
C 13	Capacitor	tantalum	3,3 μ F - 50% - 35 V	*
C 14	Capacitor	ceramic	10 nF - 80% - 50 V	*
C 15	Capacitor	ceramic	10 nF - 80% - 50 V	*
C 16	Capacitor	tantalum	47 μ F - 50% - 3 V	*
C 17	Capacitor	ceramic	4,7 nF - 80% - 25 V	*
C 18	Capacitor	ceramic	10 nF - 80% - 50 V	*
C 19	Capacitor	tantalum	47 μ F - 50% - 3 V	*
C 20	Capacitor	ceramic	10 nF - 80% - 50 V	*
C 21	Capacitor	ceramic	4,7 nF - 80% - 25 V	*
C 22	Capacitor	tantalum	47 μ F - 50% - 3 V	*
C 23	Capacitor	ceramic	10 nF - 80% - 50 V	*
C 24	Capacitor	polyester	0,1 μ F - 10% - 160 V	*
C 25	Capacitor	tantalum	47 μ F - 50% - 3 V	*
C 26	Capacitor	ceramic	10 nF - 80% - 50 V	*
C 27	Capacitor	electrolytic	1000 μ F - 50% - 18 V	*
C 28	Capacitor	ceramic	10 nF - 80% - 50 V	*
D 1	Si - Diode	1 N 4448		*
D 2	Si - Diode	1 N 4448		*
D 3	Si - Diode	1 N 4448		*
D 4	Si - Diode	1 N 4448		*
D 5	Si - Diode	1 N 4448		*
D 6	Si - Diode	1 N 4448		*
D 7	Si - Diode	1 N 4448		*
D 8	Si - Diode	1 N 4448		*
D 9	Si - Diode	1 N 4448		*
D 10	Si - Diode	1 N 4448		*
D 11	Si - Diode	1 N 4448		*
IC 1	Integrated Circuit	TBA 931 - 1	2 x OP AMP	*
IC 2	Integrated Circuit	TBA 931 - 2	2 x OP AMP	*
IC 3	Integrated Circuit	TBA 931 - 1	2 x OP AMP	*

IDENTIFICATION	PART NAME	TYPE / REMARKS	SPECIFICATIONS	ORDER NUMBER
Q 1	Transistor	BC 178 B		*
Q 2	Transistor	BC 178 B		*
Q 3	Transistor	BC 140 - 16		*
Q 4	Transistor	BC 108 B		*
Q 5	Transistor	BC 178 B		*
Q 6	Transistor	BC 160 - 16		*
Q 7	Transistor	BC 140 - 16		*
R 1	Potentiometer	carbon composition	10 k - 10% - 0,5 W	*
R 2	Resistor	carbon film	330	*
R 3	Resistor	carbon film	33 k	*
R 4	Resistor	carbon film	33	*
R 5	Resistor	carbon film	2,2 k	*
R 6	Resistor	carbon film	3,3 k	*
R 7	Resistor	carbon film	10 k	*
R 8	Resistor	carbon film	2,2 k	*
R 9	Resistor	carbon film	2,2 k	*
R 10	Resistor	carbon film	2,2 k	*
R 11	Resistor	carbon film	3,3 k	*
R 12	Resistor	carbon film	3,3 k	*
R 13	Resistor	carbon film	100 k	*
R 14	Resistor	carbon film	62	*
R 15	Resistor	carbon film	12 k	*
R 16	Resistor	carbon film	100 k	*
R 17	Resistor	carbon film	3,3 k	*
R 18	Resistor	carbon film	22	*
R 19	Potentiometer	carbon composition	1 k - 10% - 0,5 W	*
R 20	Potentiometer	carbon composition	1 k - 10% - 0,5 W	*
R 21	Resistor	carbon film	47	*
R 22	Potentiometer	carbon film	50 k - 20% - 1 W	*
R 23	Resistor	carbon film	220 k	*
R 24	Resistor	carbon film	470 k	*
R 25	Resistor	carbon film	6,8 k	*
R 26	Resistor	carbon film	6,8 k	*
R 27	Resistor	carbon film	150	*
R 28	Resistor	carbon film	12 k	*
R 29	Resistor	carbon film	100 k	*
R 30	Resistor	carbon film	100 k	*
R 31	Resistor	carbon film	3,3 k	*
R 32	Resistor	carbon film	330	*
R 33	Resistor	carbon film	2,2 k	*
R 34	Resistor	carbon film	100 k	*
R 35	Resistor	carbon film	33	*
R 36	Resistor	carbon film	330	*
R 37	Resistor	carbon film	2,2 k	*
R 38	Resistor	carbon film	68 k	*
R 39	Resistor	carbon film	33	*
R 40	Resistor	carbon film	10 k	*

IDENTIFICATION	PART NAME	TYPE / REMARKS	SPECIFICATIONS	ORDER NUMBER
R 41	Resistor	carbon film	3,3 k	*
R 42	Resistor	carbon film	10 k	*
R 43	Potentiometer	carbon composition	10 k - 10% - 0,5 W	*
R 44	Resistor	carbon film	330	*
R 45	Resistor	carbon film	33	*
R 46	Resistor	carbon film	1 k	*
R 47	Resistor	carbon film	2,2 k	*
R 48	Resistor	carbon film	180	*
R 49	Resistor	carbon film	3,3 k	*
R 50	Resistor	carbon film	1 k	*
R 51	Resistor	carbon film	3,3 k	*
T 1	Record-Input Transformer			1.062.770.03
T 2	Line Transformer			1.080.201

HEAD BLOCK ASSEMBLY 0.25"

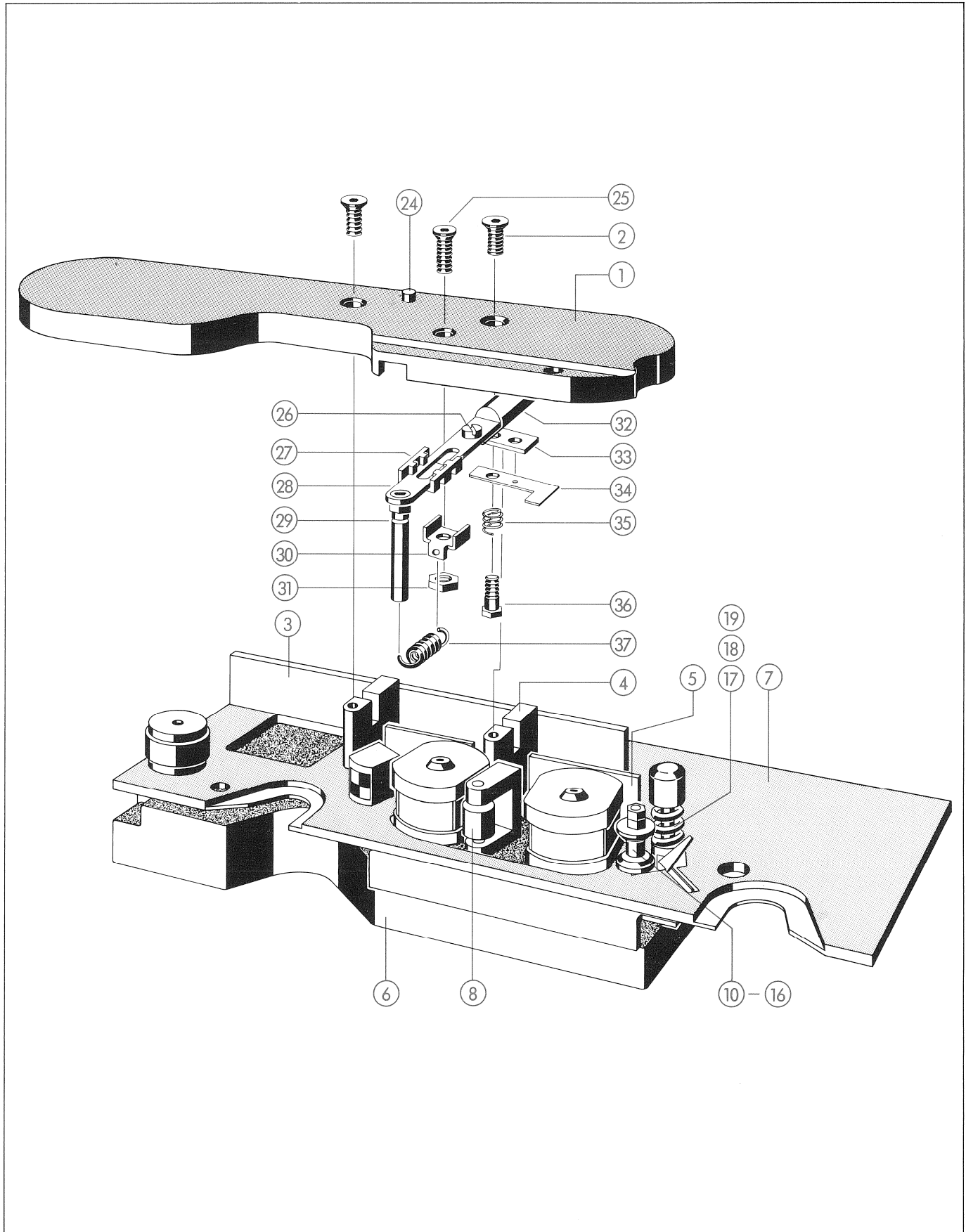

HEAD BLOCK ASSEMBLY 0,25"

INDEX	QTY	ORDER NUMBER	BEZEICHNUNG	PART NAME
		1.020.753	Kopfträger 0,25"	Head block assembly 0,25"
01	1	1.020.770	Kopfschutz 0,25"	Headblock cover 0,25"
02	2	21.51.2456	Senkschraube IS M4x10	Counter sunk screw IS M4x10
03	1	1.020.710.31	Deckleiste	Cover strip
04	2	1.020.710.08	Stütze 0,25"	Spacer mount 0,25"
05	1	1.020.751.01	Abschirmblech unten 0,25"	Screen plate 0,25"
06	1	1.020.750.02	Kopfträgerchassis	Head block chassis
07	1	1.020.752.03	Abdeckplatte 0,25"	Cover plate 0,25"
08	1	1.020.758	Zwischenberuhigungsrolle kompl.	Scrape flutter idler 0,25"
			Bandführung kompl. bestehend aus:	Tape guide, comprising :
10	1	1.020.710.25	Bandführungsbolzen	Tape guide spindle
11	2	1.020.113.03	Bandführungshülse	Spacer bush
12	1	1.020.113.03	Bandführungshülse	Spacer bush
13	3	22.01.8030	Mutter M3	Nut M3
14	2	1.080.260.12	Druckfeder	Pressure spring
15	1	24.16.1040	Sicherungsscheibe	Lock washer
16	1	22.01.8040	Mutter	Nut
17	1	1.020.715	Schere kompl.	Tape cutter
18	1	1.020.715.01	Messer	Cutter blade
19	1	1.020.715.02	Messer	Cutter blade
24	1	1.020.770.08	Taste	Button
25	1	21.51.2357	Schraube IS M3x12	Screw IS M3x12
26	1	21.01.0352	Schraube M3x4	Screw M3x4
27	1	1.020.820.03	Schiebergehäuse	Slider housing
28	1	1.020.770.03	Schieber	Slider
29	1	1.020.770.04	Abhebebolzen	Lift bolt
30	1	1.020.820.04	Halter	Bracket
31	1	22.01.8030	Mutter	Nut
32	1	1.020.770.05	Knopf	Knob
33	1	1.020.770.06	Platte	Plate
34	1	1.020.770.07	Klinke	Latch
35	1	1.020.770.10	Druckfeder	Pressure spring
36	1	1.020.715.05	Ansatzschraube	Screw
37	1	1.020.820.17	Zugfeder	Tension spring

DASHPOT ASSEMBLY COMPLETE

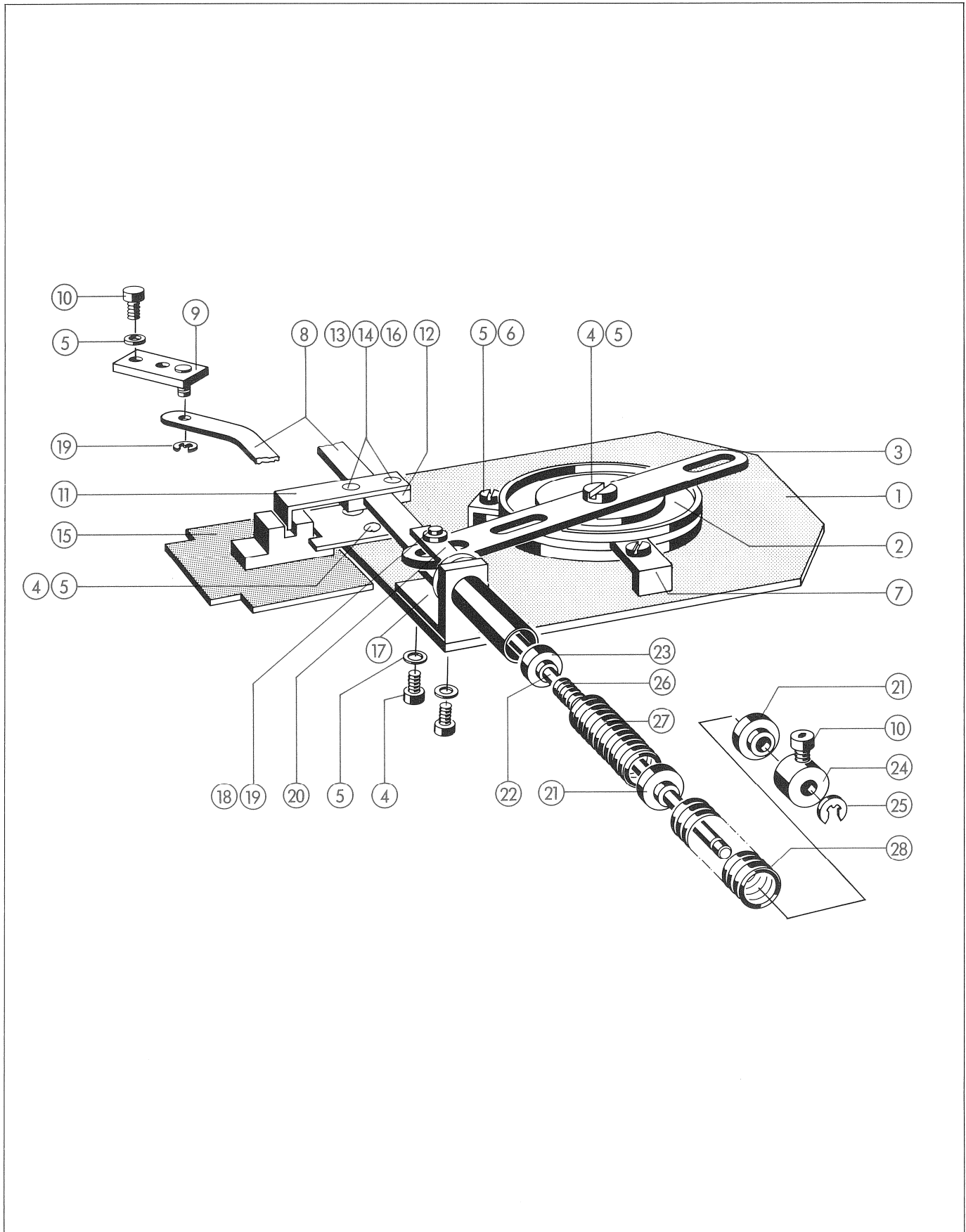

DASHPOT ASSEMBLY COMPLETE

INDEX	QTY	ORDER NUMBER	BEZEICHNUNG	PART NAME
			Dämpfungsaggregat kompl.	Dashpot assembly compl.
01	1	1.080.166.20	Platte	Mounting plate
02	1	1.080.164.00	Dämpfungsdose 0,25" kompl.	Dashpot 0.25" compl.
03	1	1.080.105.02	Hebel	Lever
04	3	21.01.0354	Schraube M3x6	Screw M3x6
05	10	24.16.1030	Sicherungsscheibe	Lock washer
06	3	21.01.0355	Schraube M3x8	Screw M3x8
07	3	1.080.164.07	Distanzrohr	Distance clip
08	1	1.080.142.05	Stange	Rod riveted
09	1	1.080.158	Hebel genietet	Lever
10	2	21.01.0353	Schraube M3x5	Screw M3x5
11	1	1.081.010.24	Schalterwinkel	Switch bracket
12	1	1.081.010.23	Gewindestück	Threaded pin
13	2	21.01.0277	Schraube M2,5x4	Screw M2,5x4
14	2	23.01.1027	U-Scheibe	Washer
15	1	1.081.144	Bandwaagen-Endschalter	Tape tension sensor end switch
16	2	24.16.1025	Sicherungsscheibe	Lock washer
17	1	1.080.175	Lager	Bearing
18	1	1.080.170.02	Gelenkbolzen	Pivot pin
19	3	24.16.3023	Wellensicherung	Circlip
20	1	1.080.170.01	Gelenkstück	Linkage
21	2	1.080.170.08	Führungshülse	Guidling sleeve
22	1	1.080.169.01	Achse	Spindle
23	1	1.080.170.05	Führungshülse	Guidling sleeve
24	1	1.080.170.10	Stellring	Adjusting ring
25	1	24.16.3032	Wellensicherung	Circlip
26	1	1.080.170.09	Druckfeder	Pressure spring
27	1	1.080.170.07	Druckfeder	Pressure spring
28	1	1.080.170.06	Druckfeder	Pressure spring

TAPE TENSION SENSOR, LEFT/RIGHT

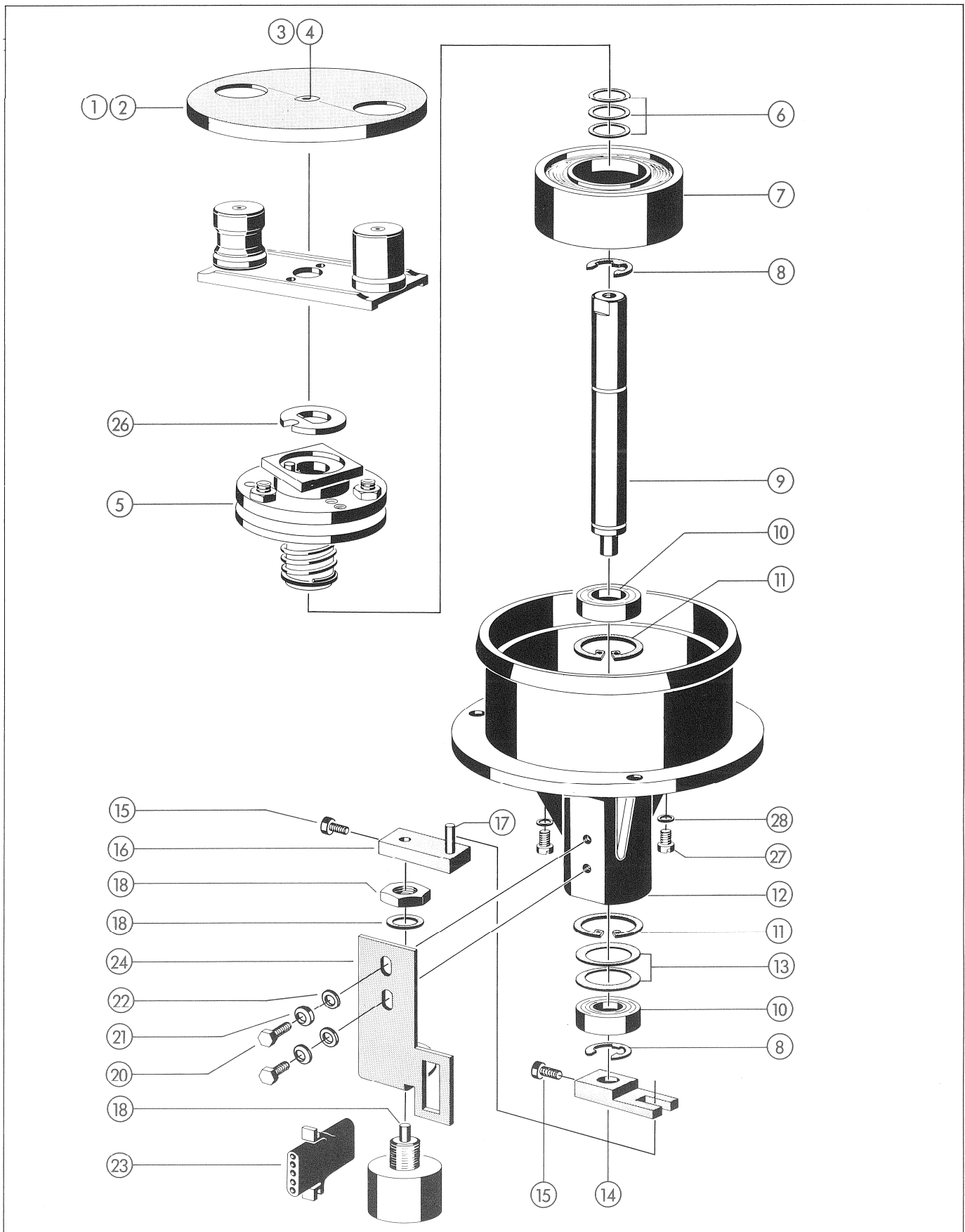

TAPE TENSION SENSOR, LEFT/RIGHT

INDEX	QTY	ORDER NUMBER	BEZEICHNUNG	PART NAME
		1.080.142	Bandwaage links	Tape tension sensor, left
		1.080.146	Bandwaage rechts	Tape tension sensor, right
01	1	1.080.142.12	Deckel graviert links	Engraved cover left
02	1	1.080.146.01	Deckel graviert rechts	Engraved cover right
03	1	1.080.142.10	Senkschraube spezial	Counter sink crew, special
04	1	24.16.3032	Wellensicherung	Circlip
05	1	1.080.148	Blockierrolle kompl.	Lock wheel armature hub compl.
06		1.080.530.06-10	Distanzscheibe	Spacer shim
07	1	1.080.153	Haltemagnet	Solenoid
08	2	24.16.3080	Wellensicherung	Circlip
09	1	1.080.142.07	Achse	Spindle
10	2	41.99.0111	Kugellager	Ball-race
11	2	24.16.4220	Seeger-Innensicherung D22	Retaining ring, internal
12	1	1.080.150	Flansch kompl.	Bearing housing, compl.
13	2	37.02.0206	Tellerfeder K D12,5/21,8	Spring washer K D12,5/21,8
14	1	1.080.310.08	Mitnehmergabel	Coupling fork
15	2	21.53.0354	Z-Schraube M3x6	Z-Screw M3x6
16	1	1.080.142.08	Mitnehmer zu Bandwaage	Coupling lever
17	1	25.06.8208	Zylinderstift o 2,5x14	Cylindricalpin 2,5x14
18	1	58.99.0110	Potentiometer mit Mutter	Potentiometer with nut
19	2	37.02.0105	Tellerfeder K	Spring washer K
20	2	21.60.4455	6-Kant Schraube M4x8	Hexagonal screw M4x8
21	2	24.16.1040	Sicherungsscheibe	Lock washer
22	2	23.01.2043	U-Scheibe	Washer
23	1	54.02.0403	Kupplungsgehäuse	Connector housing
24	1	1.080.142.06	Winkel	Angle bracket
26	1	1.080.142.11	Mitnehmerscheibe	Coupling washer
27	3	21.01.0354	Schraube M3x6	Screw M3x6
28	3	24.16.1030	Sicherungsscheibe	Lock washer

TAPE TENSION SENSOR ROLLERS, COMPLETE

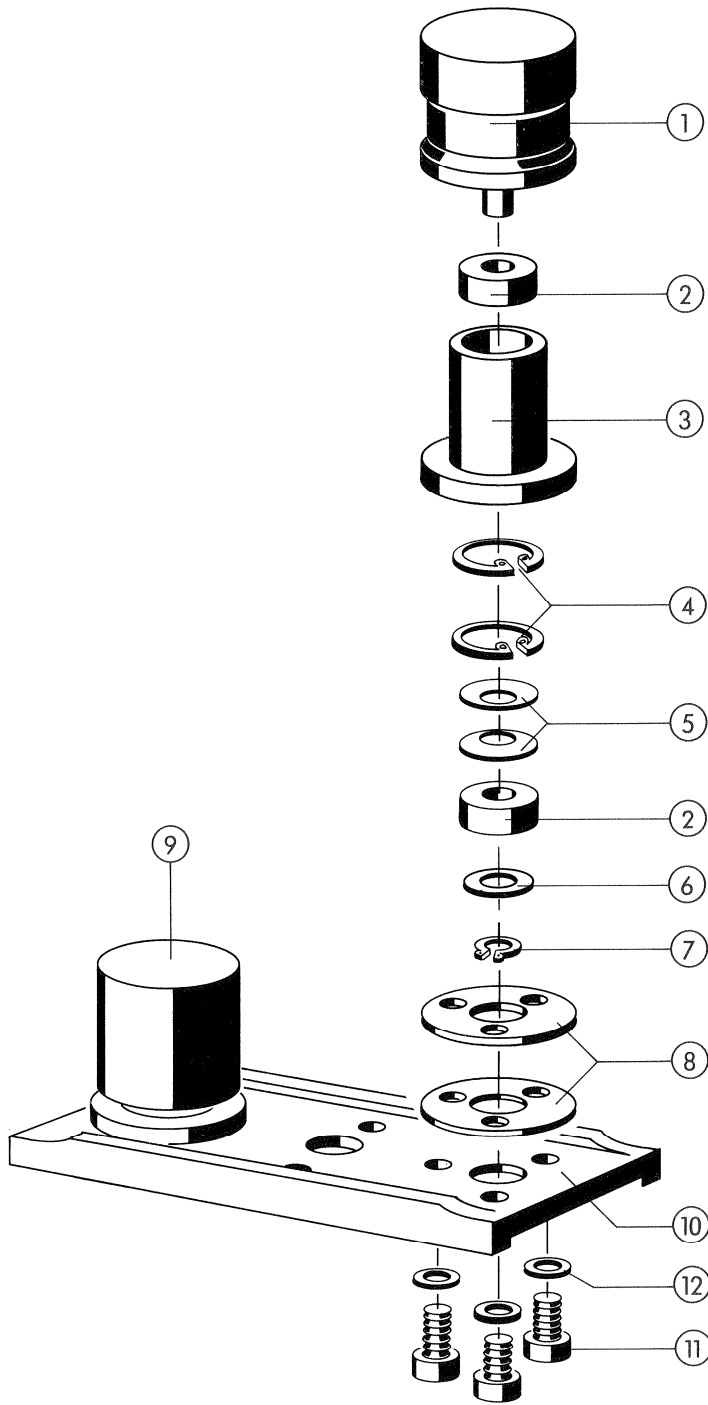

STABILIZER ROLLER, COMPLETE

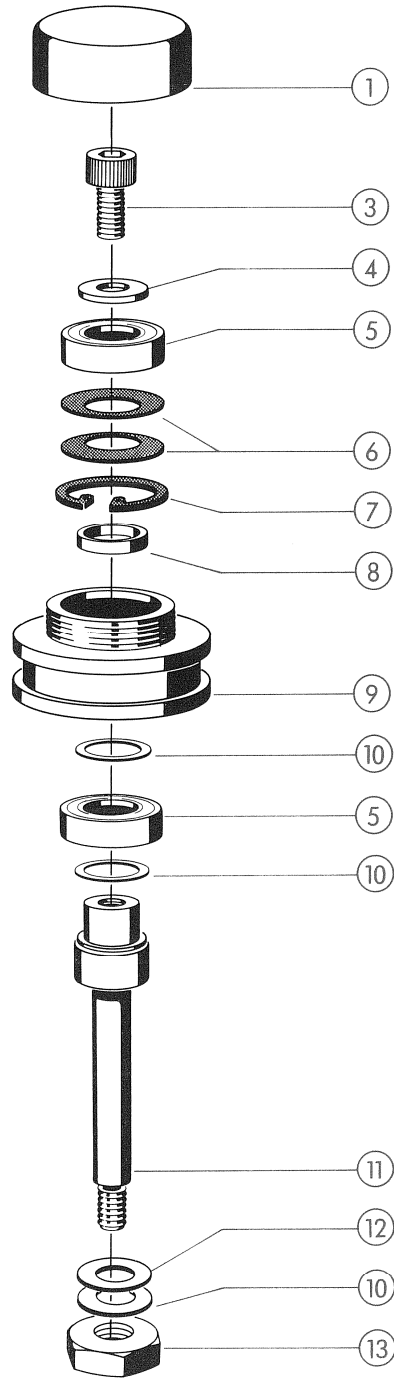

PINCH ROLLER, COMPLETE

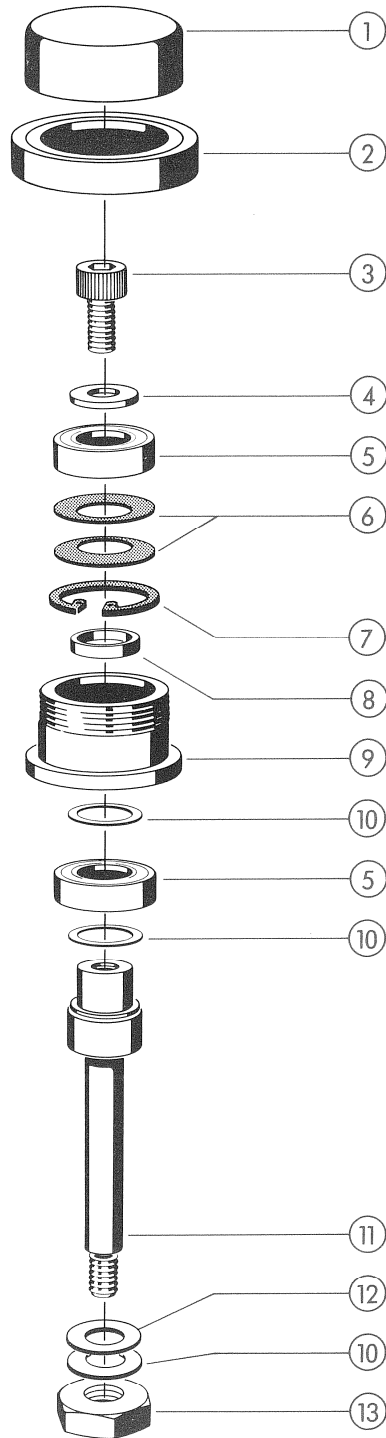

PUSH BUTTON ASSEMBLY

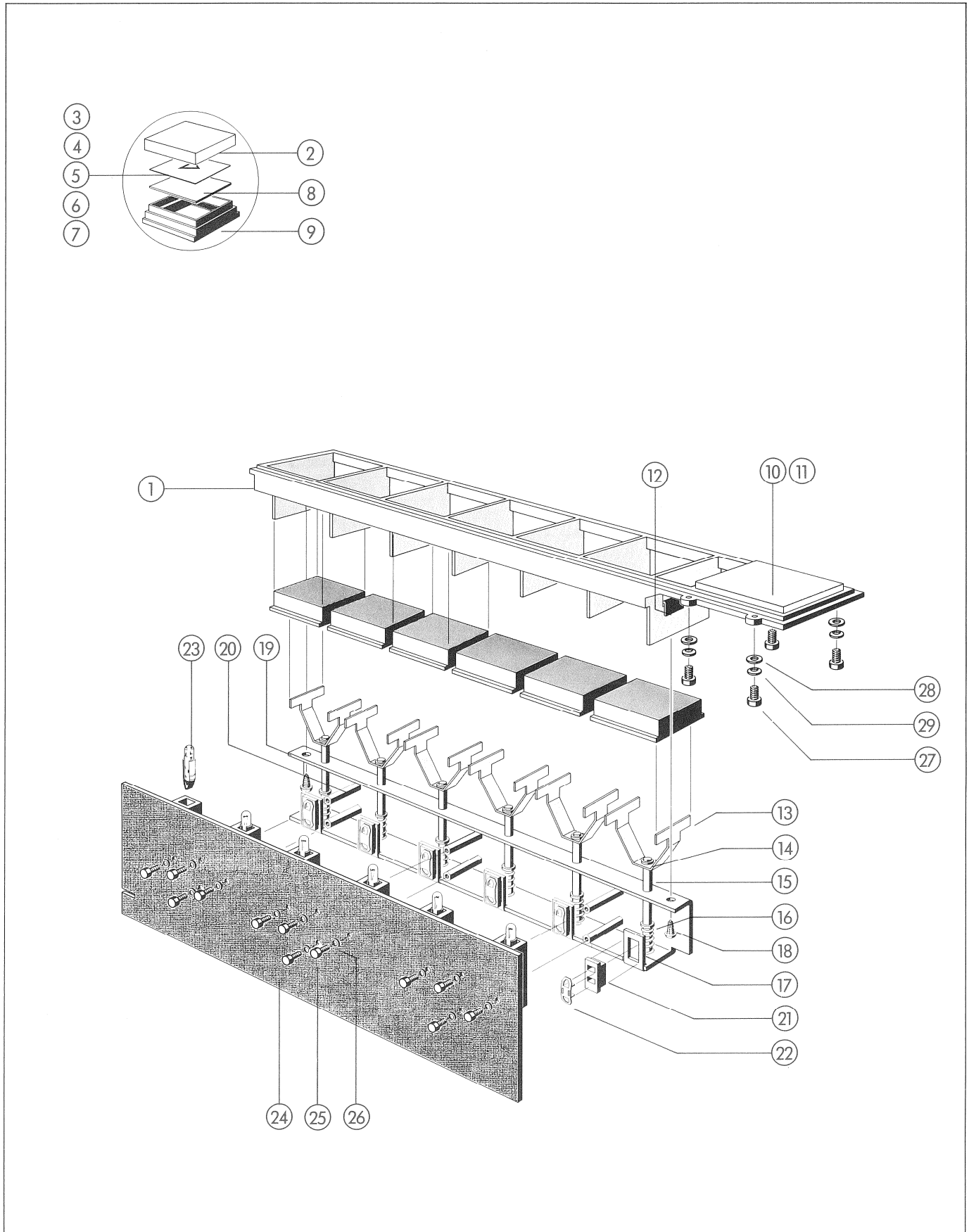

PUSH BUTTON ASSEMBLY

INDEX	QTY	ORDER NUMBER	BEZEICHNUNG	PART NAME
		1.080.260.00	Druckkasteneinheit	Push button assembly
01	1	1.080.260.01	Drucktasten-Träger	Push button support
02	6	1.080.260.03	Drucktasten-Oberteil	Push button top part
03	2	1.080.260.14	Folie "Vor-Rücklauf"	Symbol "Forward-Rewind"
04	1	1.080.260.15	Folie "Play"	Symbol "Play"
05	1	1.080.260.18	Folie "Edit"	Symbol "Edit"
06	1	1.080.260.16	Folie "Record"	Symbol "Record"
07	1	1.080.260.17	Folie "Stop"	Symbol "Stop"
08	6	1.080.260.19	Blende	Mask
09	6	1.080.260.02	Drucktaste-Unterteil	Push button lower part
10	1	1.080.260.26	Zähler-Abdeckung	Timer fascia
11	1	1.228.810.02	Filterglas bedruckt	Anti-glare glass printed
12	2	22.16.2501	Winkel-Mutter	Clip-on nut
13	6	1.080.260.09	Tasthalter	Button holder
14	6	24.16.3019	Benzing Sicherung	Circlip
15	6	1.080.270.00	Kontakthalter	Contact holder
16	12	24.16.3032	Benzing Sicherung	Circlip
17	6	1.080.260.12	Druckfeder	Pressure spring
18	2	20.21.7355	Blechschraube D4,8/9,5	Self-tapping screw D4.8/9.5
19	1	1.080.260.08	Lagerschiene	Bearing rail
20	6	1.010.034.27	Mutterbolzen M3x19	Threaded bolt M3x19
21	6	55.02.0101	Gehäuse zu Schiebekontakt	Wiper holder
22	6	1.010.007.55	Kontaktfeder	Wiper contact
23	6	51.02.0145	Glühlampe 24V, 0,04A	Lamp 24V, 0.04A
24	1	1.080.275.00	Befehlstastensatz Print, bestückt	Push button print, assembled
25	12	21.26.0354	Schraube M3x6	Screw M3x6
26	12	24.16.1030	Sicherungsscheibe	Lock washer
27	4	21.01.0201	Schraube M2x3	Screw M2x3
28	4	1.228.211.02	Spez. U-Scheibe	Spec. Washer
29	4	24.16.1020	Sicherungsscheibe	Lock washer

SPOILING MOTOR, COMPLETE

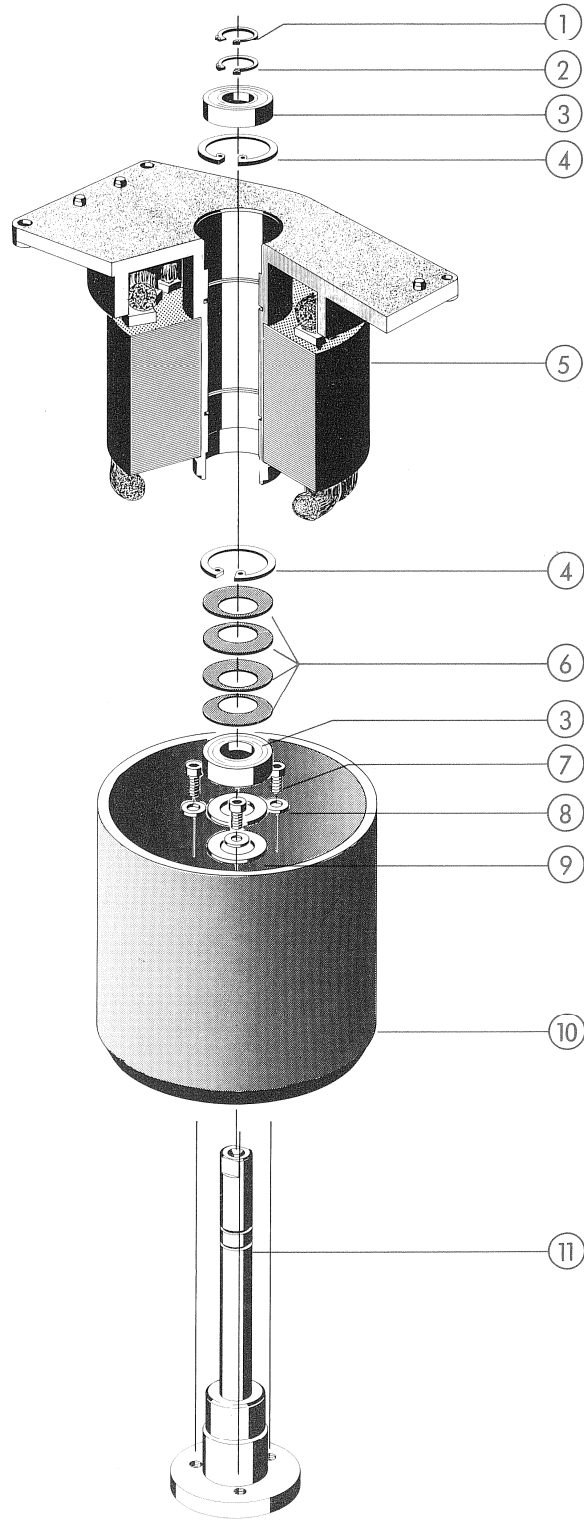

SPOOLING MOTOR AND BRAKES

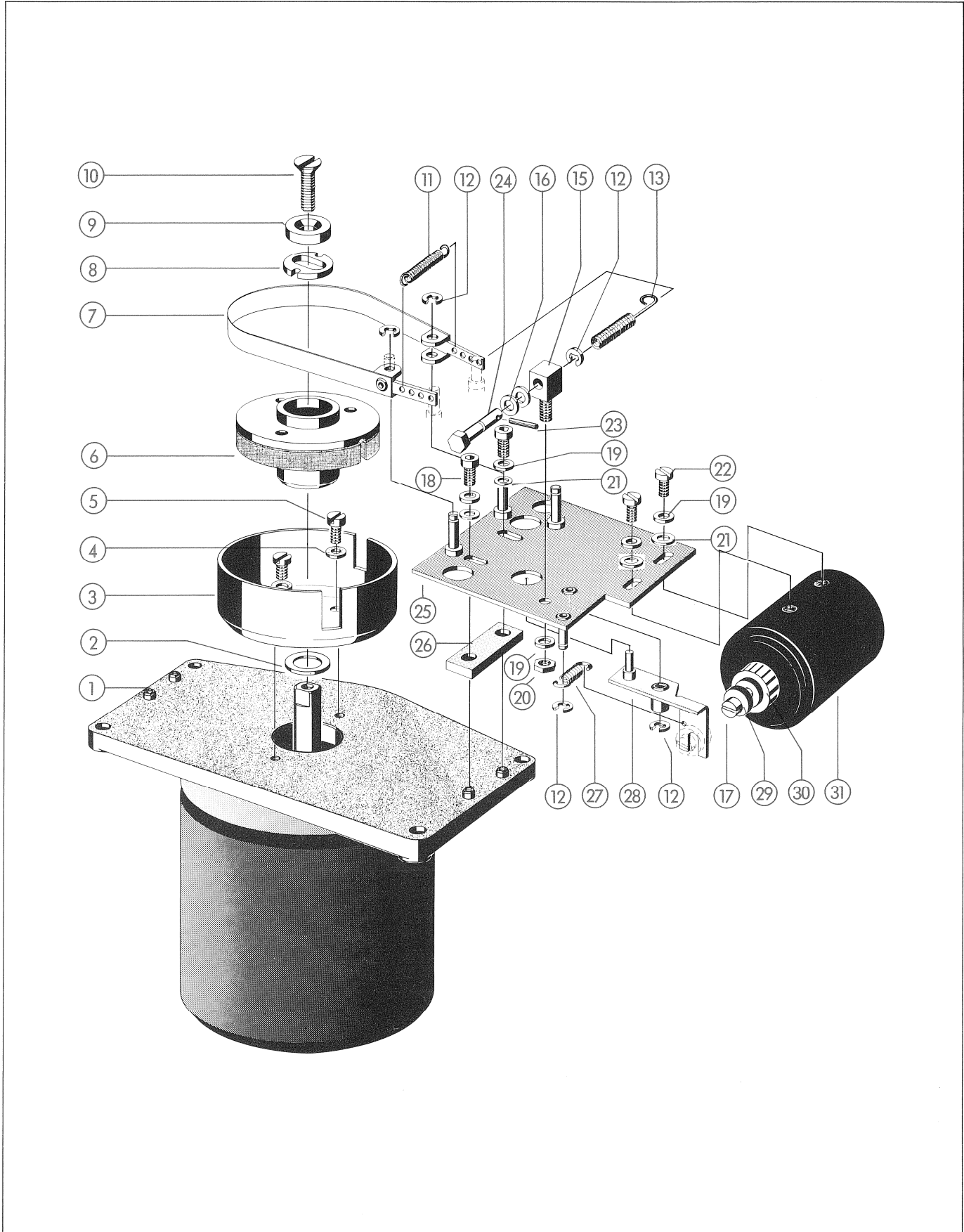

SPOOLING MOTOR AND BRAKES

INDEX	QTY	ORDER NUMBER	BEZEICHNUNG	PART NAME
			Wickelmotor und Bremsen	Spooling motor and brakes
01	1	1.021.240.00	Wickelmotor kompl.	Spooling motor compl.
02		1.080.530.06-10	Distanzscheibe	Spacer shim
03	1	1.080.105.03	Schutzhaube	Protective hood
04	2	24.16.1030	Sicherungsscheibe	Lock washer
05	2	21.01.0353	Schraube M3x5	Screw M3x5
06	1	1.080.250.00	Bremsrolle kompl.	Brake drum compl.
07	1	1.080.238.00	Bremsband kompl.	Brake band compl.
08	3	1.080.105.07	Mitnehmerscheibe	Coupling washer
09	1	1.080.105.08	Pressring	Clamp ring
10	1	21.53.2457	Senkschraube M4x12	Counter sunk screw M4x12
11	1	1.080.230.05	Zugfeder	Tension spring
12	5	24.16.3032	Benzing Sicherung	Circlip
		1.080.230.00	Bremschassis links, kompl.	Brake chassis left, compl.
		1.080.240.00	Bremschassis rechts, kompl.	Brake chassis right, compl.
13	1	1.080.230.06	Zugfeder	Tension spring
15	1	1.080.230.01	Lager-Bolzen	Support bolt
16	2	37.01.0102	Tellerfeder K	Spring washer K
17	1	1.014.753.01	Mitnehmerschraube	Coupling screw
18	2	21.53.0455	Schraube M4x8	Screw M4x8
19	5	24.16.1040	Sicherungsscheibe	Lock washer
20	1	22.01.8040	Sechskant Mutter	Hexagonal nut
21	4	23.01.1043	U-Scheibe	Washer
22	2	21.53.0454	Schraube M4x6	Screw M4x6
23	1	25.16.2106	Schwerspannhülse	Spring pin
24	1	1.080.230.02	Einstellbolzen	Adjusting bolt
25	1	1.080.233.00	Bremschassis links	Brake chassis left
	1	1.080.243.00	Bremschassis rechts	Brake chassis right
26	1	1.080.105.21	Distanzplatte	Spacer plate
27	1	1.080.230.04	Zugfeder	Tension spring
28	1	1.080.236.00	Bremshebel	Brake lever
29	2	1.080.170.03	Anschlagscheibe	End-stop washer
30	1	1.014.753.00	Anker kompl.	Solenoid plunger compl.
31	1	1.014.750.00	Magnet	Solenoid

PINCH ROLLER ASSEMBLY

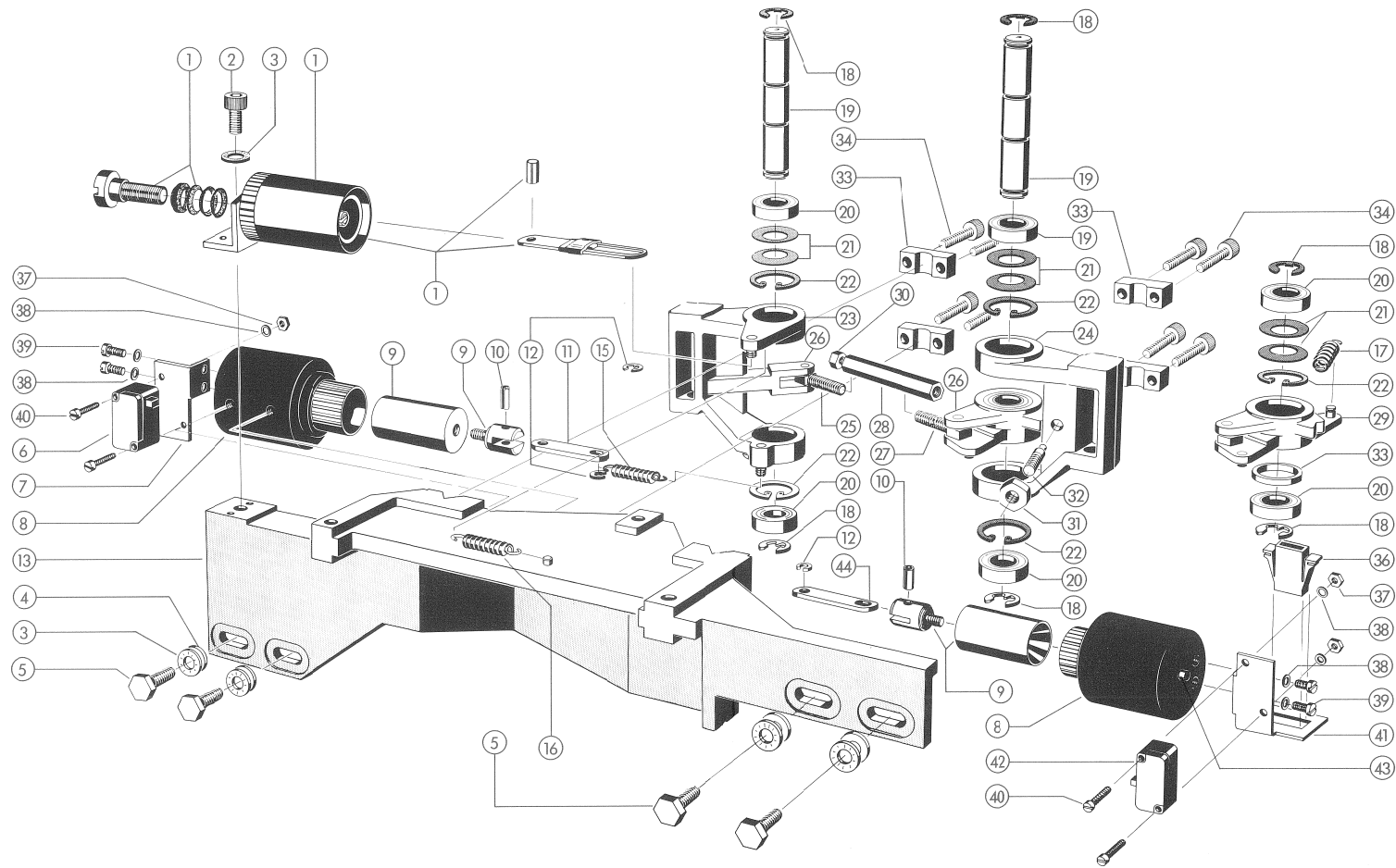

PINCH ROLLER ASSEMBLY

INDEX	QTY	ORDER NUMBER	BEZEICHNUNG	PART NAME	INDEX	QTY	ORDER NUMBER	BEZEICHNUNG	PART NAME
		1.080.124.00	Andruckaggregat	Pinch roller assembly					
01	1	1.080.138.00	Dämpfungspumpe kompl.	Dashpot compl.	35	1	1.080.125.05	Distanzhülse	Spacer sleeve
02	1	21.53.0455	Schraube M4x8	Screw M4x8	36	1	54.02.0403	Kupplungsgehäuse	Coupling housing
03	13	24.15.1040	Sicherungsscheibe	Lock washer	37	4	22.01.8030	Mutter	Nut
04	4	23.01.2043	U-Scheibe	Washer	38	8	24.16.1030	Sicherungsscheibe	Lock washer
05	4	21.60.4455	Schraube M4x8	Screw M4x8	39	4	21.01.0353	Schraube M3x5	Screw M3x5
06	1	55.01.0124	Mikro-Switch	Microswitch	40	4	21.01.0372	Schraube M3x16	Screw M3x16
07	1	1.080.120.10	Winkel	Bracket	41	1	1.080.120.08	Halter	Bracket
08	2	1.014.745.00	Andruckmagnet	Pressure solenoid	42	1	55.01.0124	Mikro-Switch	Microswitch
09	2	1.014.743.00	Anker kompl.	Solenoid plunger, compl.	43	2	1.080.120.09	Schaltbolzen	Switching bolt
10	2	25.06.8356	Zylinder-Stift ø 4x10	Cylinder pin ø 4x10	44	1	1.080.120.06	Stange	Rod
11	1	1.080.123.00	Stange	Rod					
12	2	24.16.3023	Benzing-Sicherung	Circlip					
13	1	1.080.124.01	Andruckträger	Pressure level					
15	1	1.080.120.14	Zugfeder 1/4"	Tension spring 1/4"					
16	1	1.080.230.05	Zugfeder	Tension spring					
17	1	1.080.125.04	Zugfeder	Tension spring					
18	6	24.16.3080	Wellensicherung D8	Circlip D8					
19	2	1.080.126.01	Welle	Spindle					
20	6	41.99.0111	Kugellager	Ball-race					
21	6	37.02.0206	Tellerfeder K	Spring washer K					
22	5	24.16.4220	Innensicherung D22	Retaining ring D22					
23	1	1.080.134.01	Vorberuhigungsarm	Stabilizer arm					
24	1	1.080.126.02	Andruckarm	Pressure arm					
25	1	1.080.135.02	Gelenkstück mit Rechtsgewinde	Eye screw, righth-hand thread					
26	2	1.080.135.03	Achse	Spindle					
27	1	1.080.130.02	Gelenkstück mit Linksgewind	Eye screw, left-hand thread					
28	1	1.080.120.04	Gewindestange	Connecting rod					
29	1	1.080.130.01	Andruckhebel	Pressure lever					
30	1	22.01.8050	Mutter	Nut					
31	1	22.01.8040	Mutter	Nut					
32	1	1.080.125.03	Oesenschraube	Eye screw					
33	4	1.080.124.02	Klemmstück	Clamp					
34	8	21.53.0471	Schraube M4x14	Screw M4x14					